

Načrtovanje elektronike za EMC



študentska delavnica in tekmovanje

NAGRADNI SKLAD >6000 EUR



Laboratorij za fotovoltaiiko
in optoelektroniko



Laboratorij za
električne stroje



Laboratorij za regulacijsko tehniko in
močnostno elektroniko

KOLEKTOR



Čemu?

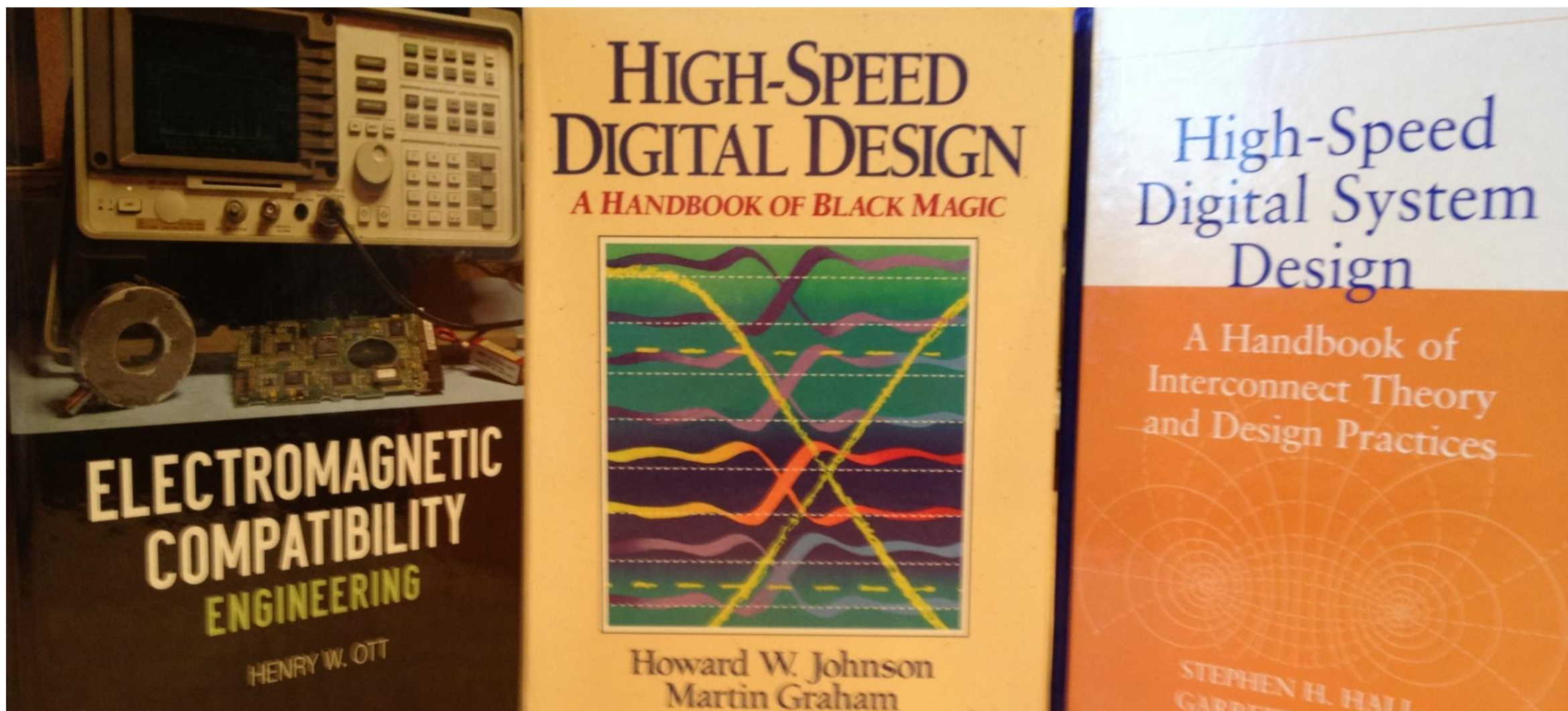

1. EMC delavnica 2016: HELLA SATURNUS

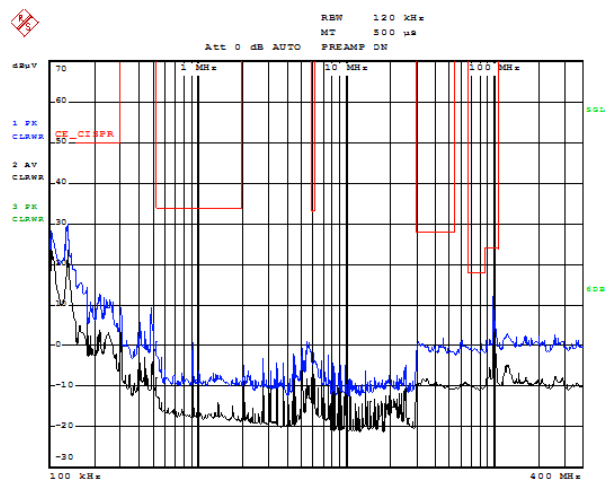

Urban Gregorc

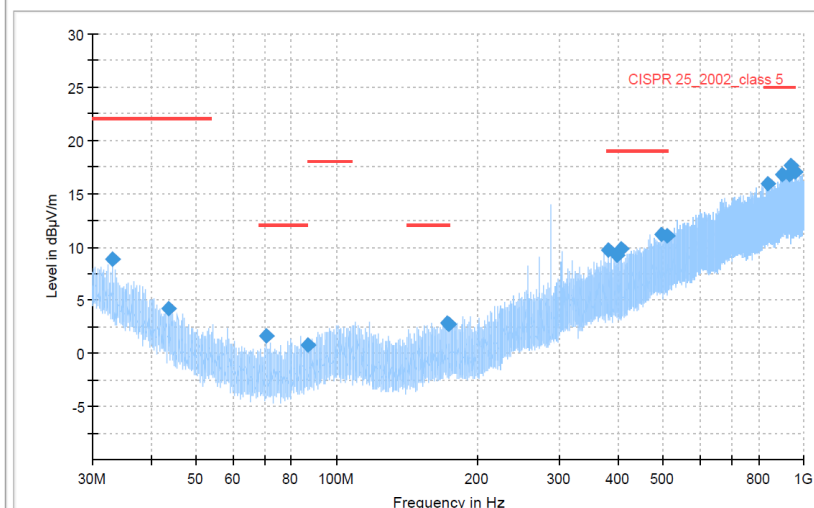
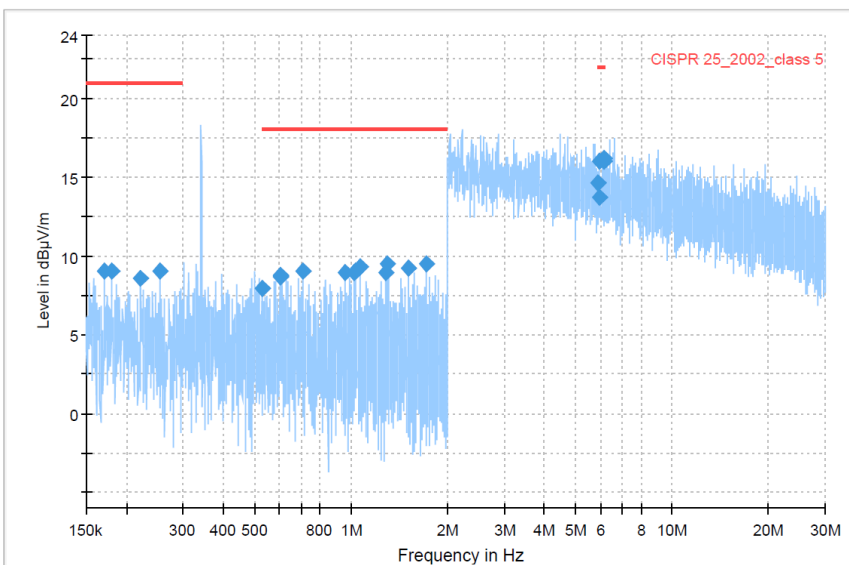

2. EMC delavnica 2017: ISKRA EMECO

Igor Strojinc

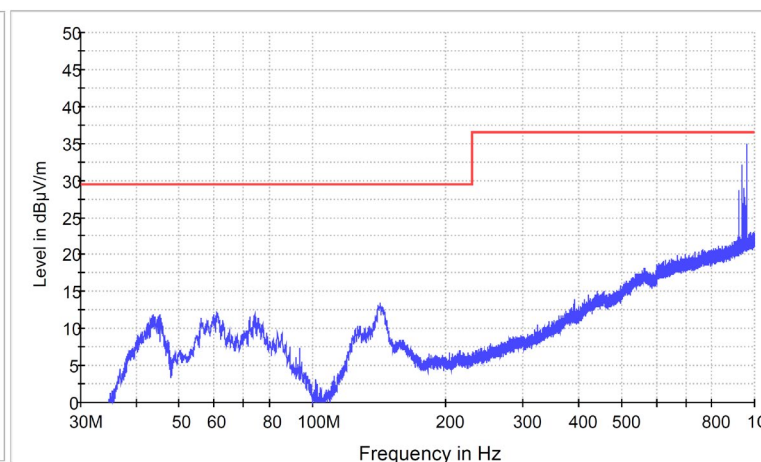
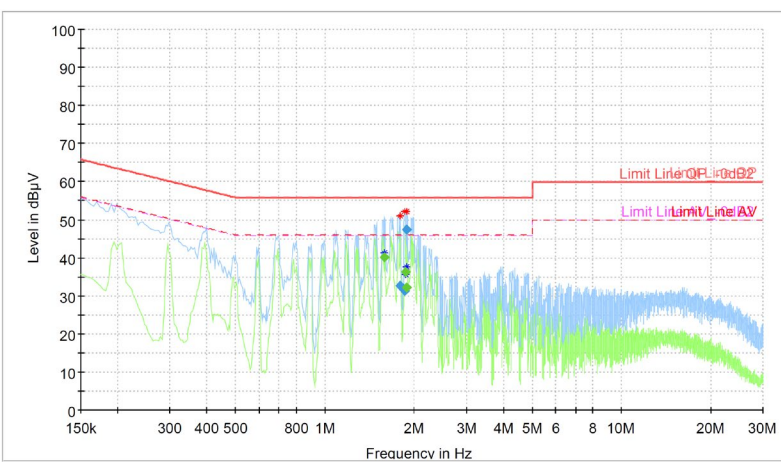
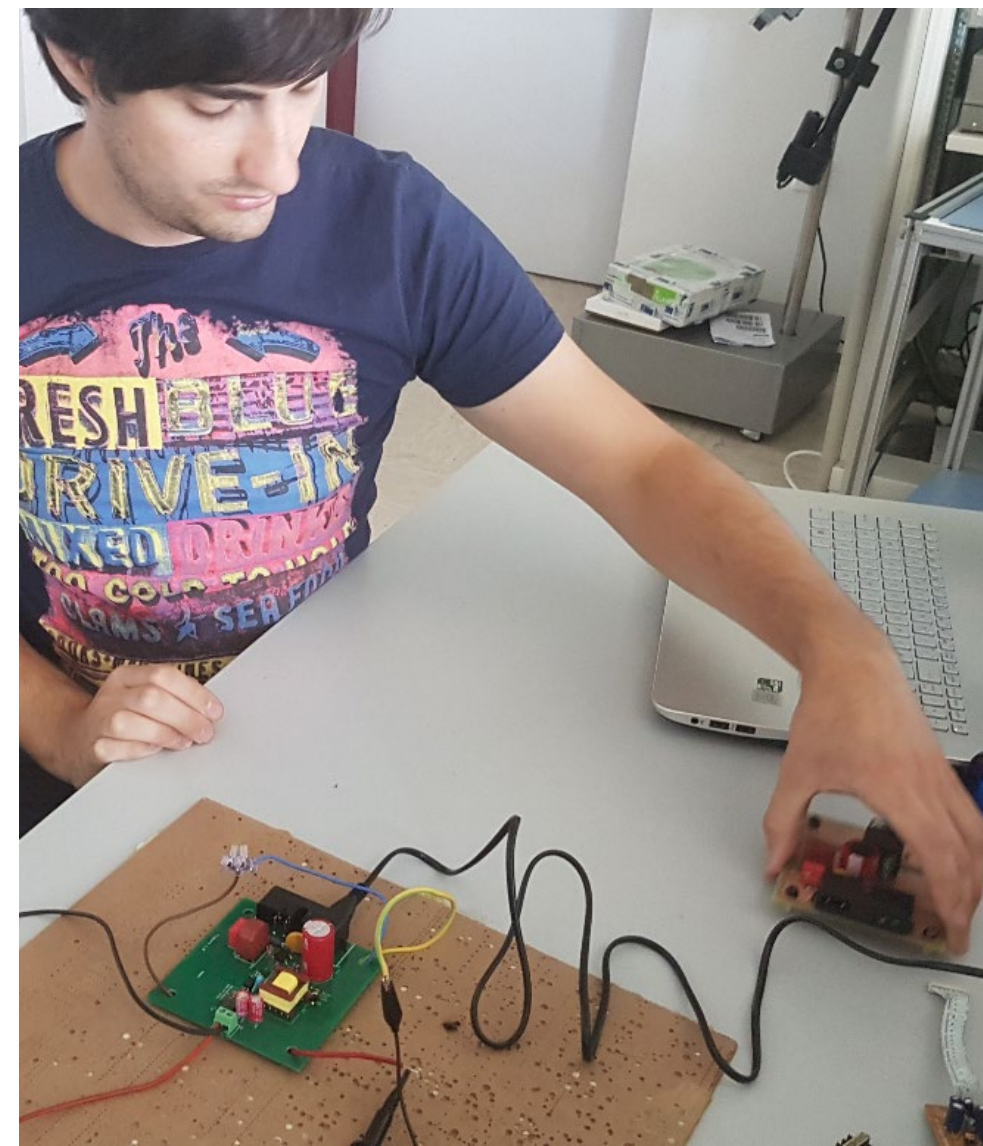
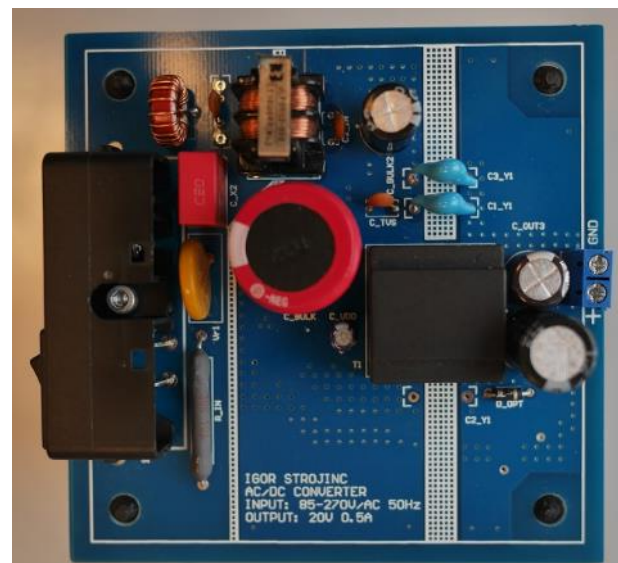
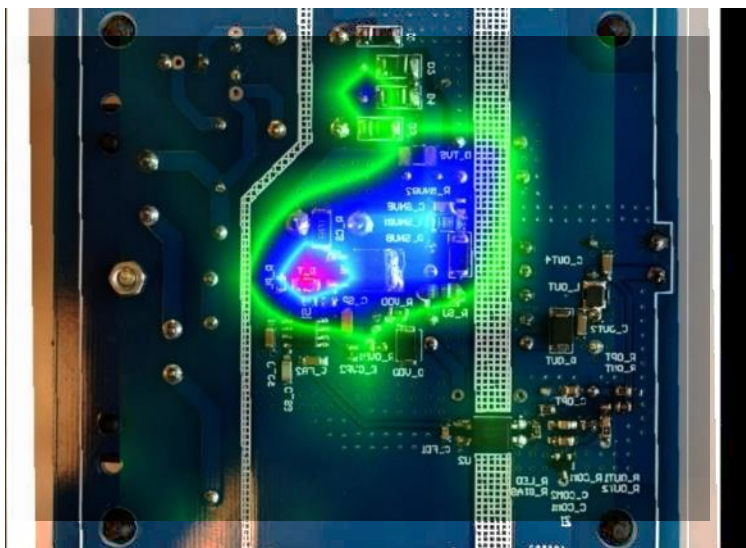

3. EMC delavnica 2018: MAHLE EDS

Matic Novak

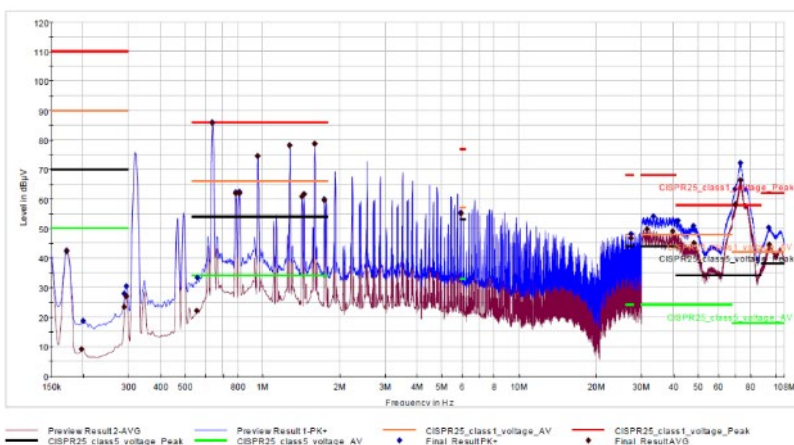

Slika 25: Rezultat na 48V+ priključku s PKAV detektorji in razredom 5 mejnimi vrednostmi

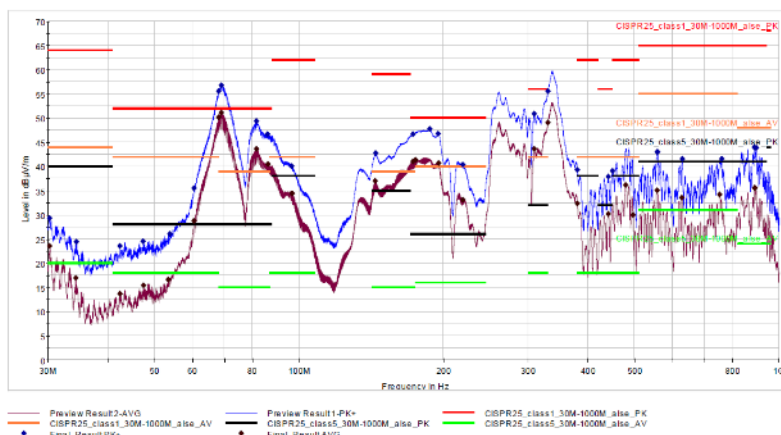

30 MHz – 1000 MHz

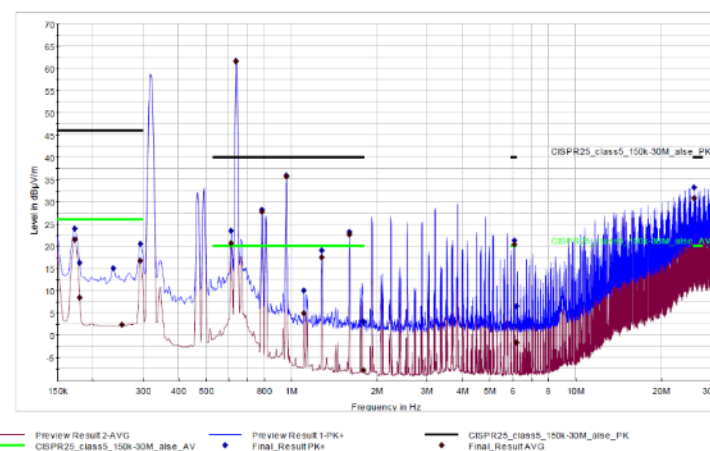

150 kHz – 30 MHz

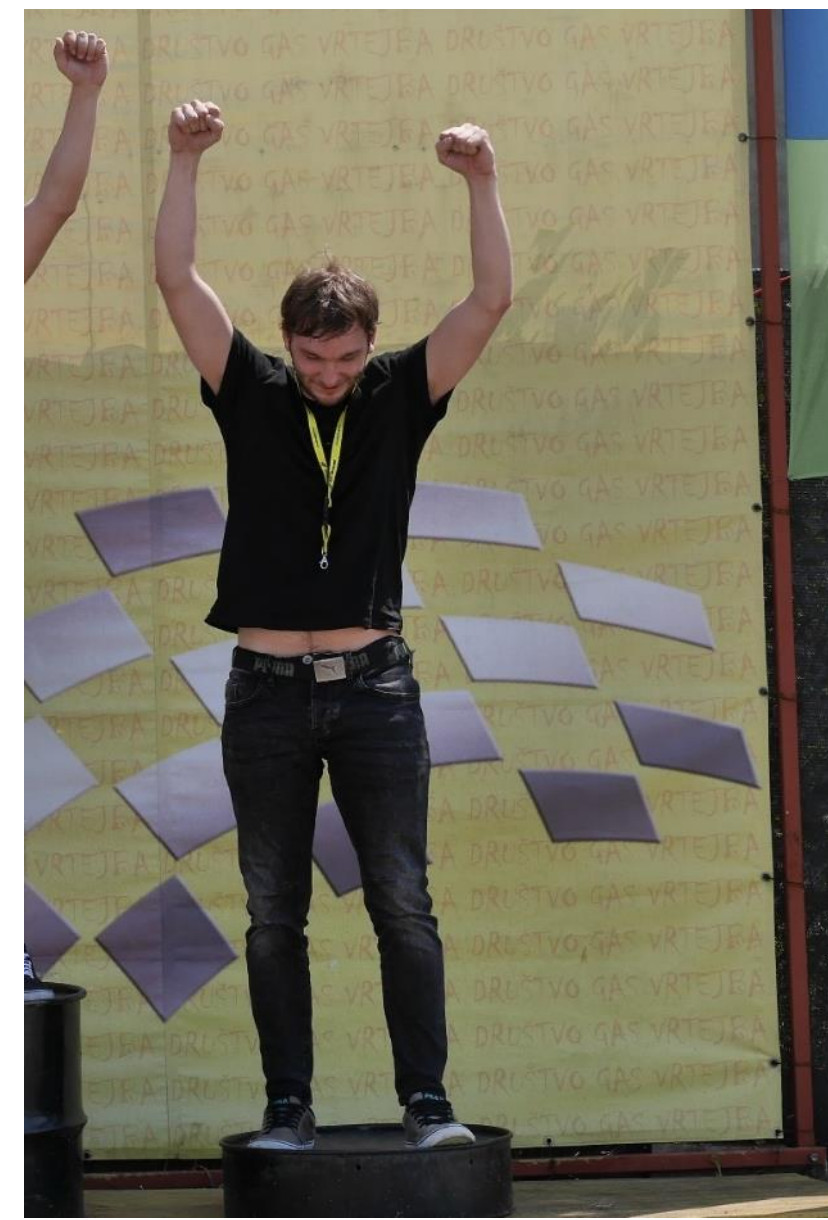

Slika 52: Rezultat s PKAV detektorji in razredom 5 mejnimi vrednostmi v frekvenčnem področju 30 MHz – 1000 MHz

Slika 50: Rezultat s PKAV detektorji in razredom 5 mejnimi vrednostmi v frekvenčnem področju 150 kHz – 30 MHz

4. EMC delavnica 2019: MAHLE EDS

Žiga Šmelcer

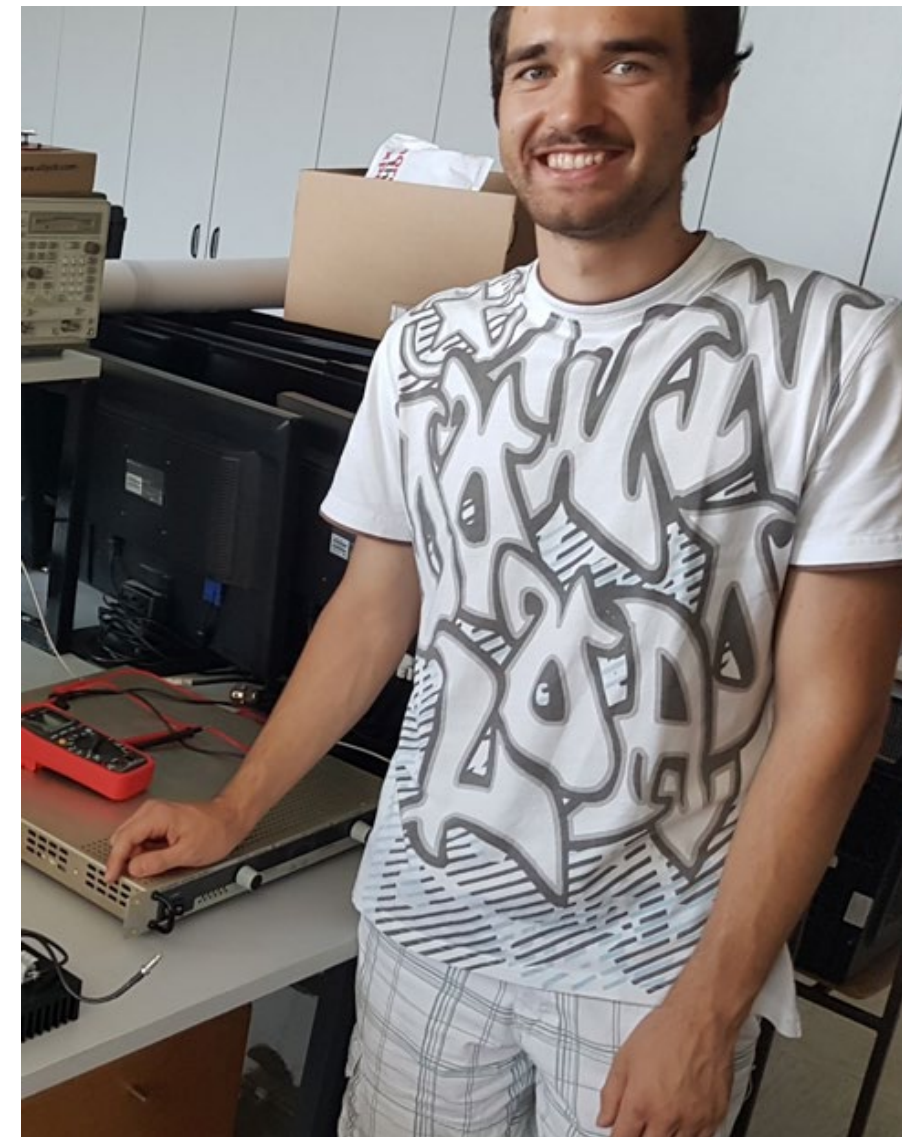
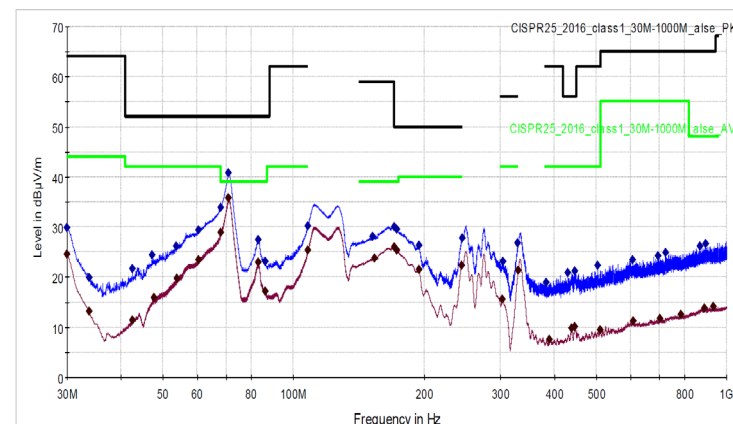
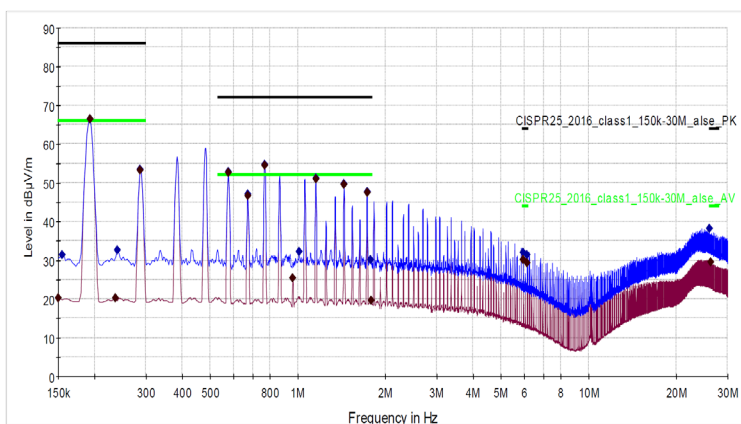
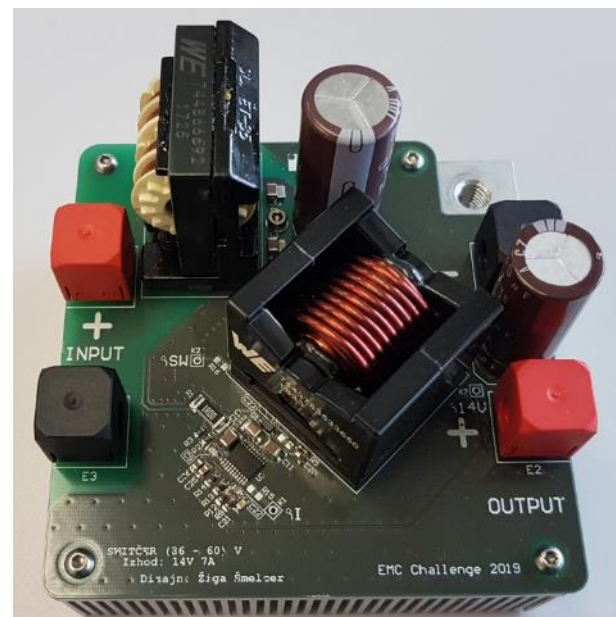
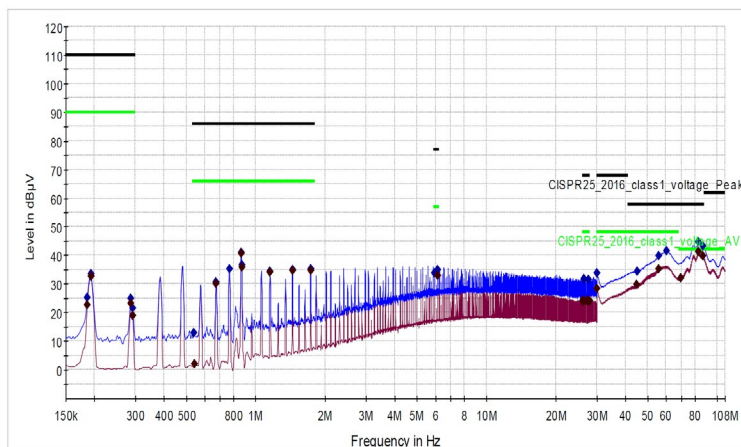

5. EMC delavnica 2020: HELLA SATURNUS

Martin Debevc

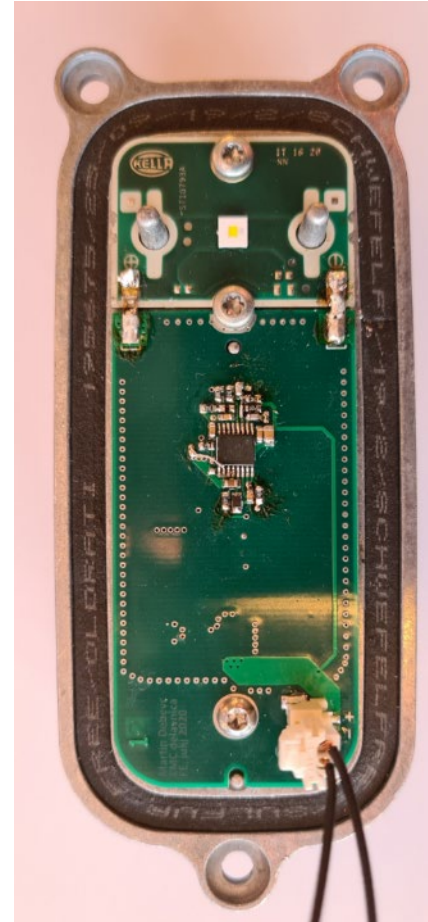
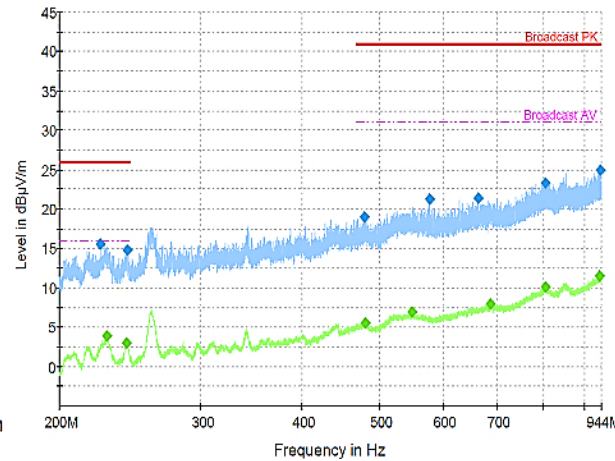
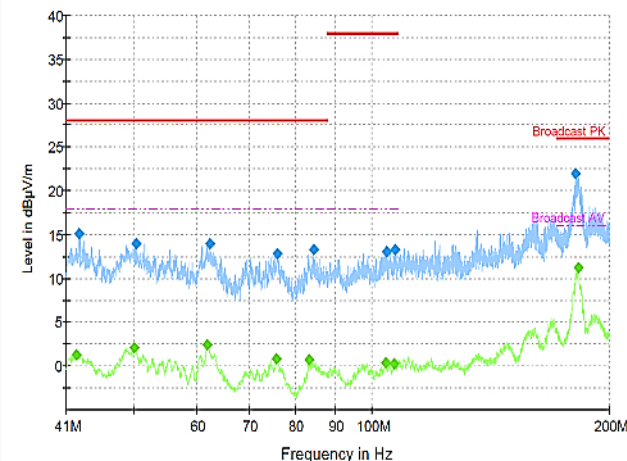
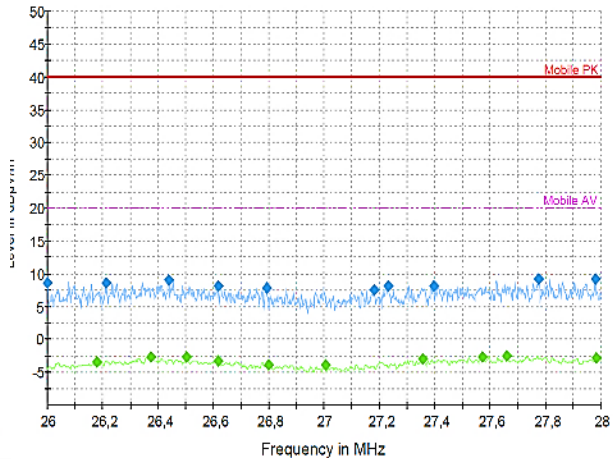
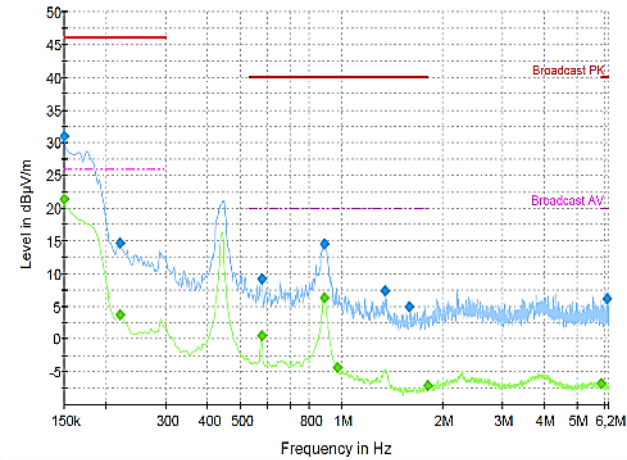

6. EMC delavnica 2023 - KOLEKTOR

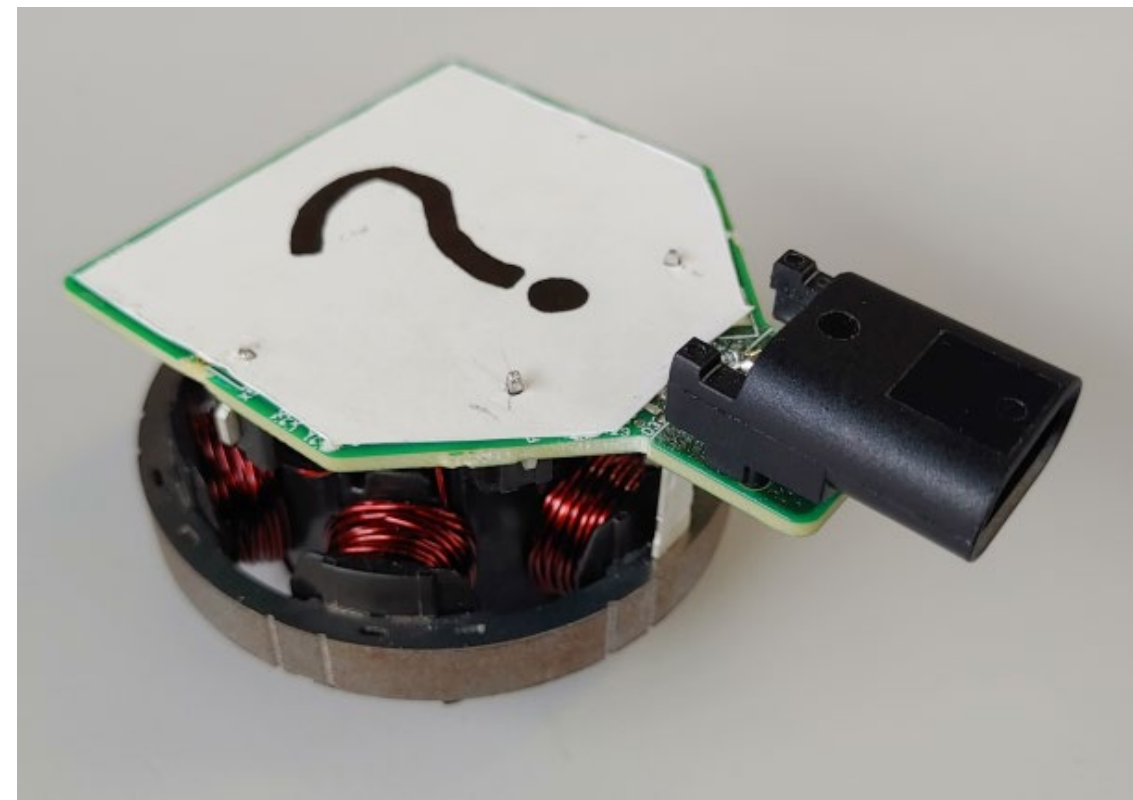
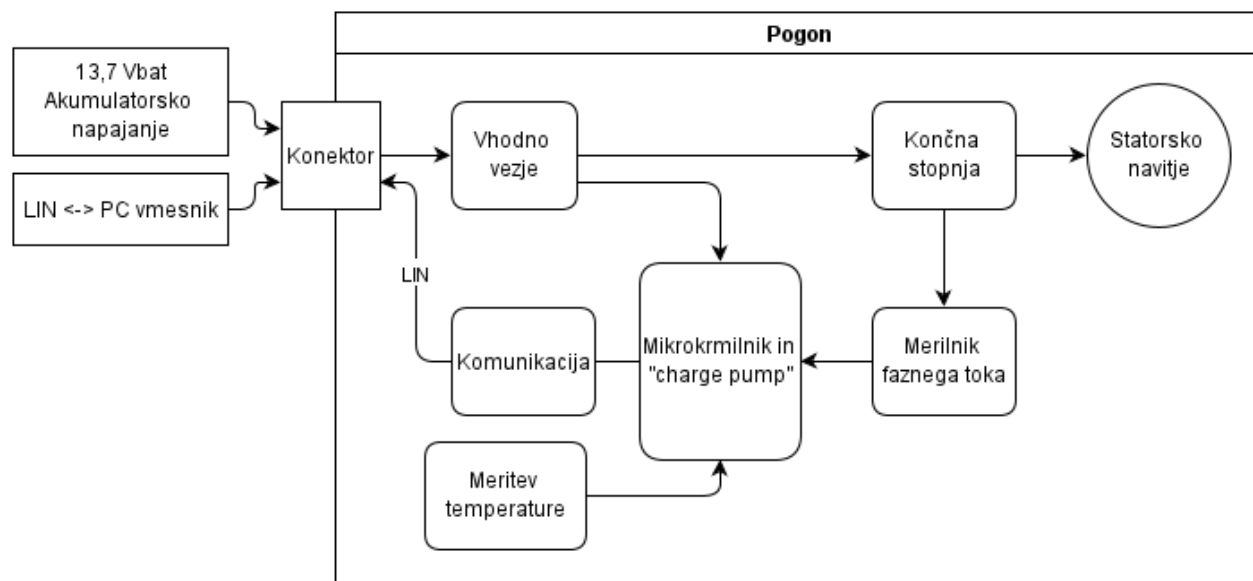

Kako?

Termin	Vsebina	Predavatelj
torek 21.2.	Predstavitev EMC delavnice in izziva	Marko Jankovec (FE LPVO), Jaka Ivančič (Kolektor)
torek 28.2.	Osnove BLAC motorjev	Damjan Miljavec (FE LES). Simon Mandelj (GEM m.)
torek 7.3.	Osnove krmiljenja BLAC motorjev	Peter Zajec (FE LRTME). Jaka Ivančič (Kolektor)
torek 14.3	Elektromagnetna združljivost	Marko Jankovec (FE LPVO), Mirko Ivančič (Amiteh)
torek 21.3	Načrtovanje filtrov	Kristijan Saksida (Mahle EDS)
torek 28.3.	Praktična delavnica načrtovanja filtrov	Tomo Kozeljnik in (Wurth elektronik)
torek 4.4.	Novosti v Altium designerju	Matija Markovič (Computer Controls)
torek 11.4.	Dizajn za proizvodnjo v avtomobilski industriji	Hella Saturnus
nedelja 16.4.	Oddaja PCB in BOM	
petek 5.5.	Ekskurzija v Kolektor mobility	
ponedeljek 5.6.	Oddaja končnih projektov	
12-16.6	Meritve EMC	
torek 27.6.	Zaključek EMC delavnice	

Nagrade

Podjetje	Nagrada
Kolektor	Denarna nagrada (2000 €)
Mahle EDS	Denarna nagrada (1000 €)
Forvia - Hella Saturnus	Denarna nagrada (700 €)
Instrumentation technologies	Preliminarne meritve v EMC komori, Red pitaya STEM-lab (550 €)
GEM motors	Denarna nagrada (500 €)
SIQ	<i>Izvedba vseh meritev,</i> 2 uri meritev v EMC komori in tehnično darilo (500 €)
Amiteh	Osciloskop Rigol DS1054Z (354 €)
Goap	Denarna nagrada (300 €)
Iskra emeco	Denarna nagrada (200 €)
Würth elektronik	<i>Brezplačni vzorci</i> doživljenjski free-refill design kit po izbiri (~ 200€)
Svet elektronike	Boni za nakup v spletni trgovini in letna naročnina na revijo Svet elektronike (200 €)
Intectiv	<i>Izdelava tiskanih vezij</i>

Prijave po letnikih

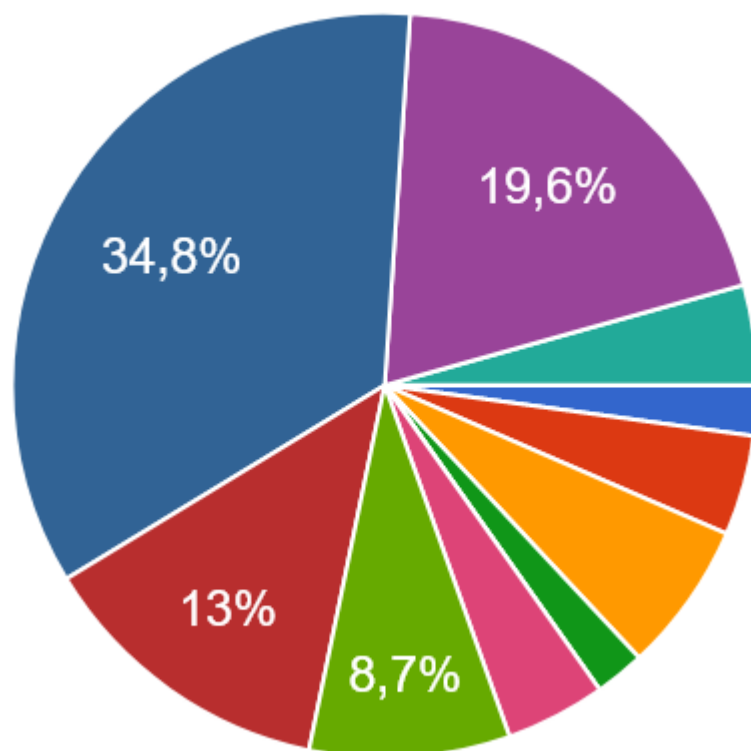

48 študentov

- Dijak
- 1. stopnja VS-EL, 1. letnik
- 1. stopnja VS-EL, 2. letnik
- 1. stopnja VS-EL, 3. letnik
- 1. stopnja UN-MM, 1. letnik
- 1. stopnja UN-MM, 2. letnik
- 1. stopnja UN-EL, 1. letnik
- 1. stopnja UN-EL, 2. letnik
- 1. stopnja UN-EL, 3. letnik
- 2. stopnja UN-EL, 1. letnik
- 2. stopnja UN-EL, 2 letnik
- Doktorski študij

Prijave po smereh

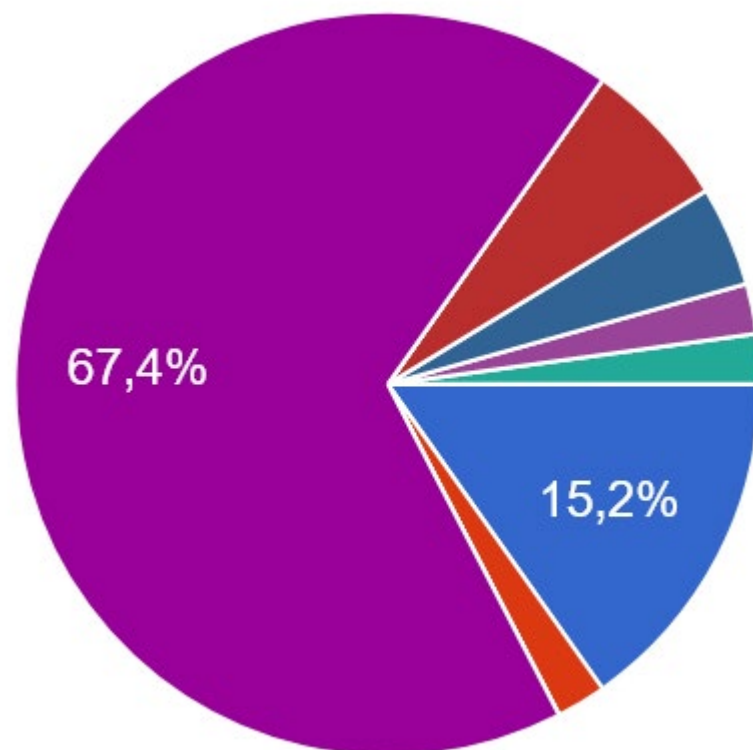

48 študentov

- Brez usmeritve
- Avtomatika
- Avtomatika in informatika
- Biomedicinska tehnika
- Elektronika
- Elektroenergetika
- Energetika in mehatronika
- ETAP
- Mehatronika
- Robotika
- Tehniška kakovost
- IKT
- Multimedija

Izkušnje z načrtovanjem vezij

48 študentov

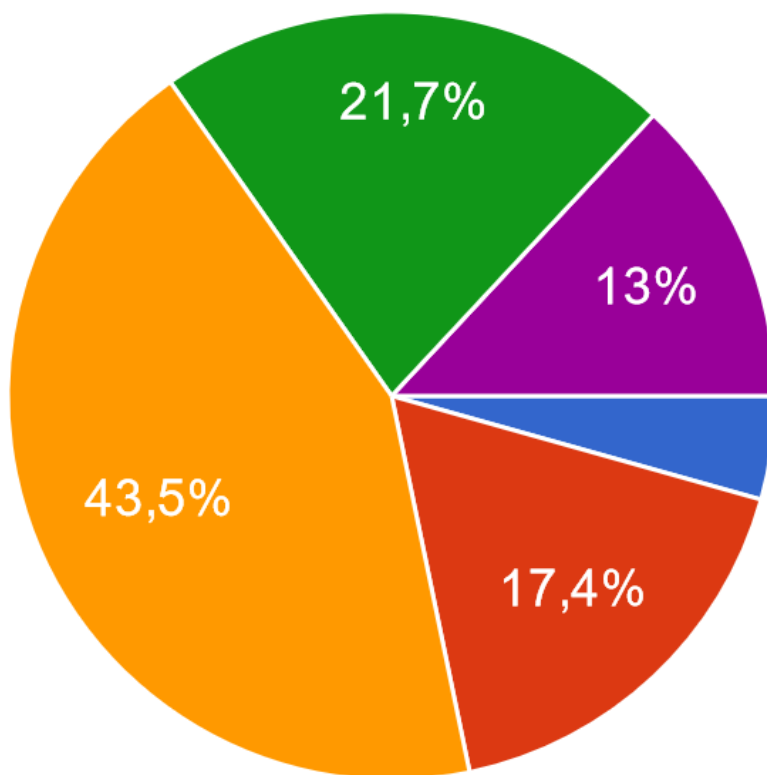

- Jih nimam.
- Sem že enkrat poizkusil.
- Sem že izdelal svoje vezje.
- Sem že izdelal več vezij, tudi kompleksnejša za lastne potrebe.
- Sem že delak kompleksna vezja po naročilu za podjetja.

Sodelovanje pri tekmovanju

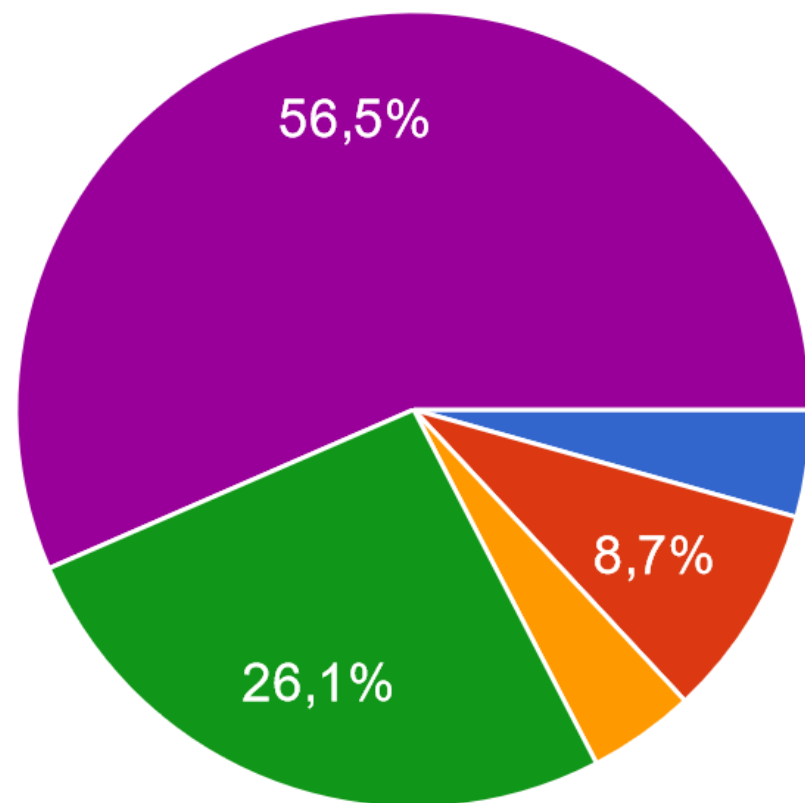

48 študentov

- Tekmovanje me ne zanima.
- Bi, a nimam časa.
- Bi, če bi bila mamljiva nagrada.
- Bi, če le ne bo prezahtevno.
- Vsekakor.

izr. prof. dr. Marko Jankovec

Predstavitev delavnice



Laboratorij za fotovoltaiiko
in optoelektroniko

Zakaj?

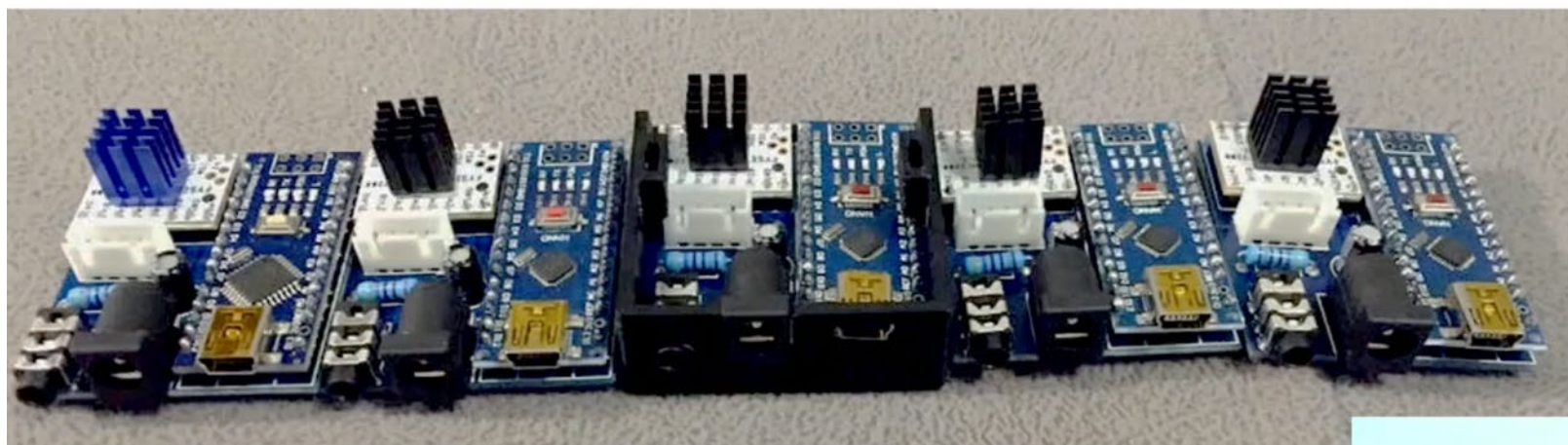

Jaka Ivančič

Predstavitev podjetja Kolektor in izziva delavnice

Predmet načrtovanja

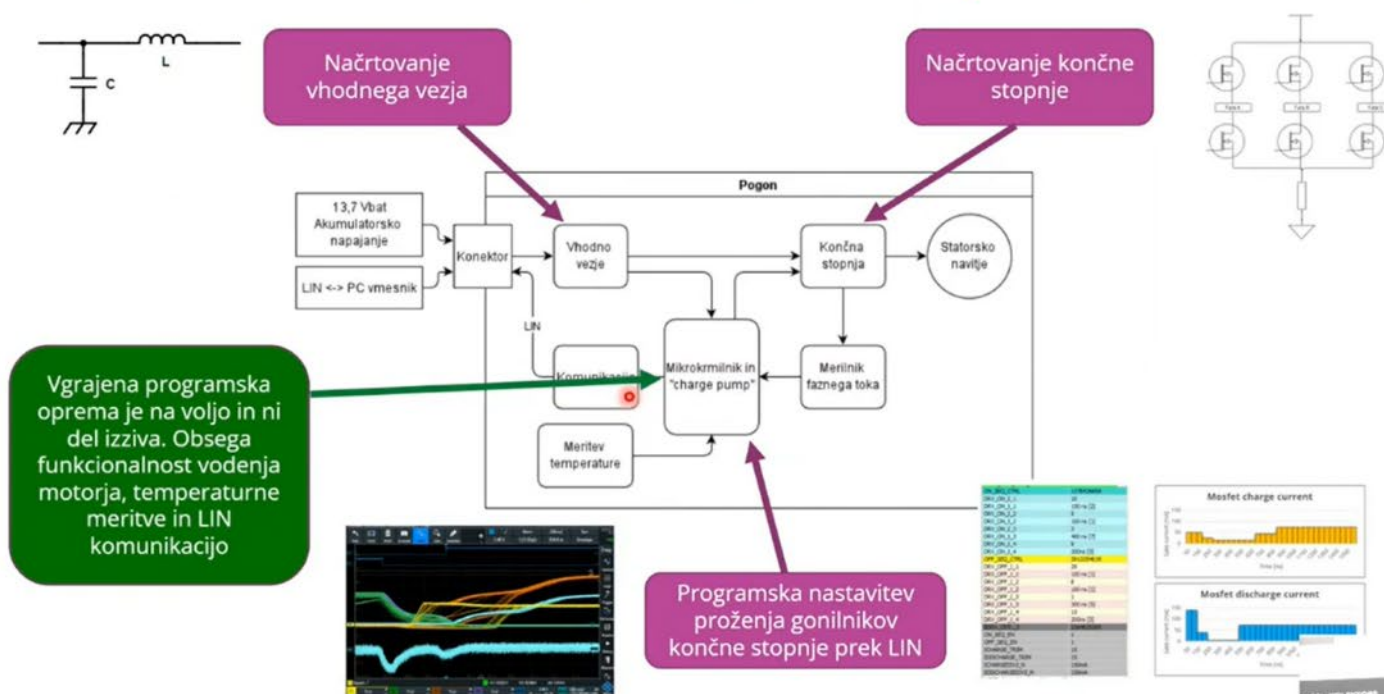

prof. dr. Damijan Miljavec

Osnove elektronsko komutiranih motorjev



Laboratorij za
električne stroje

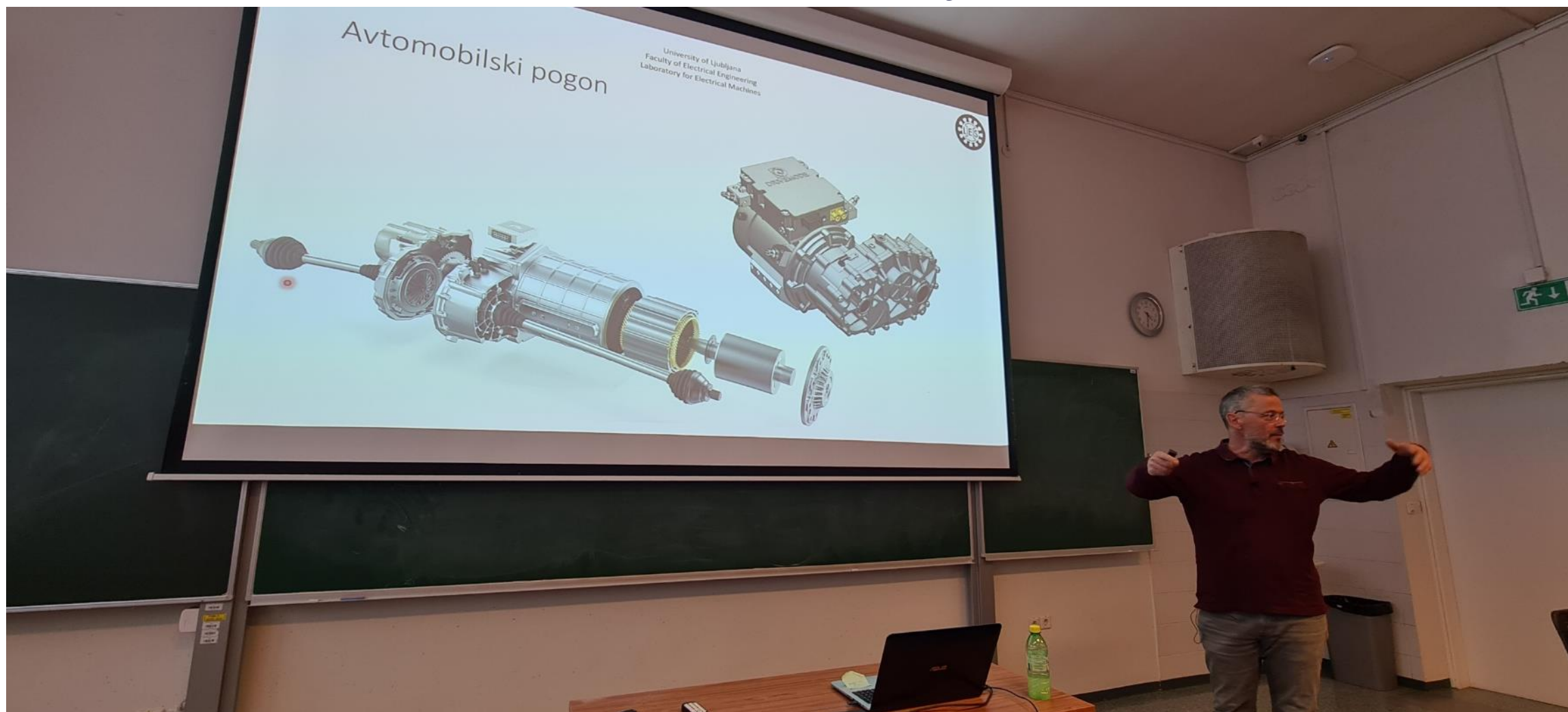

dr. Simon Mandelj

Razvoj pogonskih motorjev za električno mobilnost



KONCEPT

Battery
Internal Combustion Engine
Generator
Power Split Device
Electric Motor

UPORABA

PREDNOSTI

- Majhna sprememba koncepta vozila
- Hibridna ali samo električna rešitev pogona

SLABOSTI

- Kompleksno rešitev
- Izkoristek

GEMmotors

izr. prof. dr. Peter Zajec

Močnostna stopnja BLAC pogona - razsmernik



Laboratorij za regulacijsko tehniko
in močnostno elektroniko

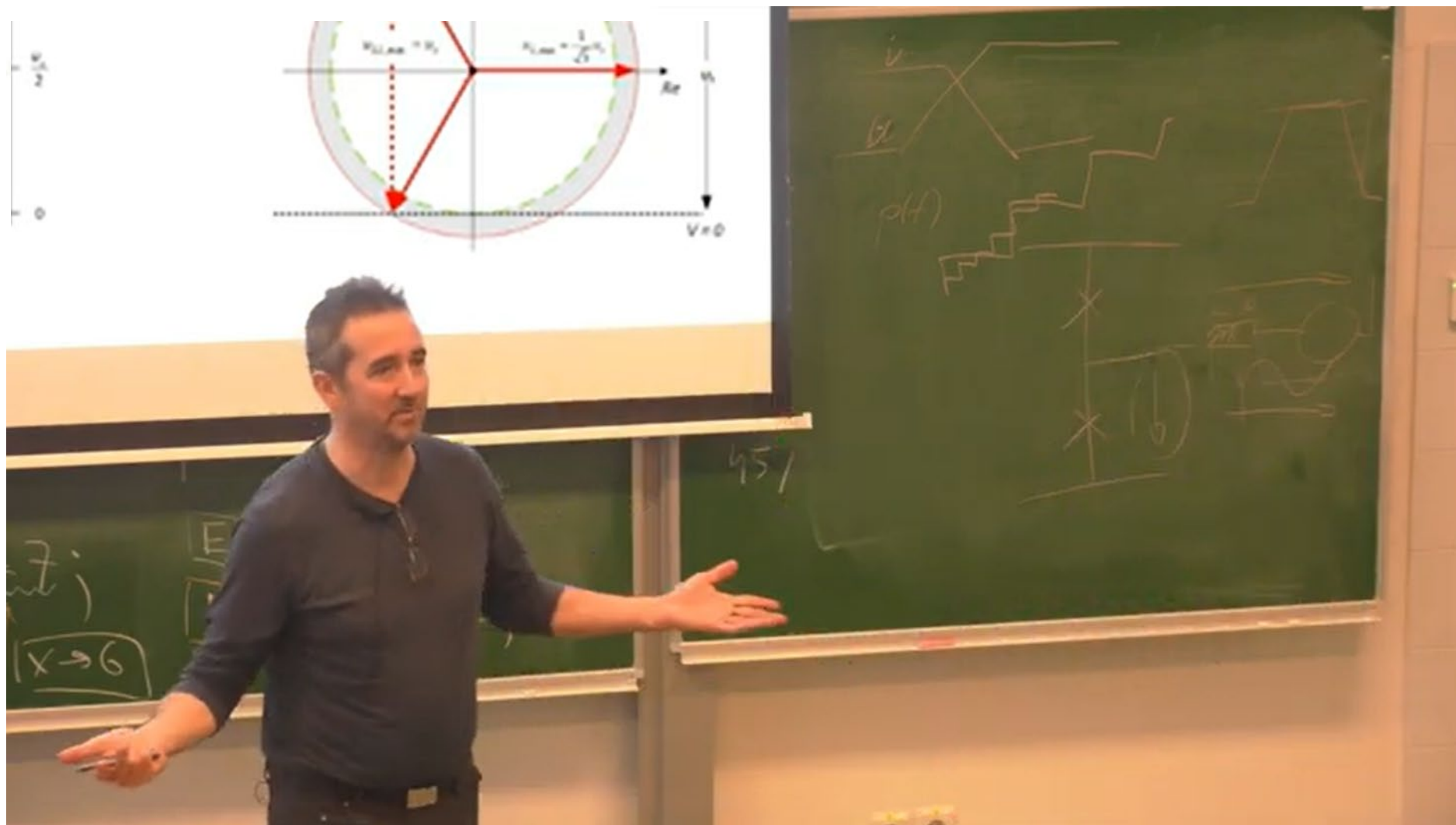

Dejan Beguš in Jaka Ivančič

Električni pogon - Razvoj vgrajene programske in strojne opreme

The image shows a man in a blue shirt standing in a lecture hall, pointing at a green chalkboard. To his left is a large projection screen displaying technical diagrams and text. The chalkboard contains handwritten notes and circuit diagrams.

Projection Screen Content:

- Diagram of a 3-phase system with three sine waves labeled FAZAA, FAZAB, and FAZAC.
- Text: SVM
- Text: 3 fazni sistem
- Text: rski koordinatni sistem
- Diagram of a motor with a blue arrow indicating rotation.
- Footer: 3/7/2023 All rights reserved by KOLEKTOR® 5

Chalkboard Content:

- Handwritten notes: $x \rightarrow 6$, $E \leftarrow \text{stubs} \% 10$, $D \leftarrow \text{stubs} / 10$, trideset .
- Handwritten circuit diagrams on the right side of the board.

izr. prof. dr. Marko Jankovec

Osnove EMC



Laboratorij za fotovoltaiiko
in optoelektroniko



Mirko Ivančič

Merjenje EMC



▶ Conducted
▶ Radiated

14. 03. 2023

Merjenje

2

dr. Gregor Ergaver

Predstavitev projektov MAHLE EDS

MAHLE

The presentation screen displays the following information:

- 400V pogonski motor za osebna vozila**
 - Kompakten 170kW pogonski motor s samo 21 kg mase
 - Maksimalna hitrost motorja 21.000 rpm
- 800V POGONSKI MOTORJI**
 - Brezkrtlačni električni motor za e-kompresorje za električna vozila
 - Uporabljen za klimatizacijo kabine vozila, hlajenje baterij, pogskega motorja in ostalih komponent
- 48V 40kW POGONSKI SISTEM**
 - Kompaktni 40kW pogonski sistem na 48V
 - Integriran inverter z avtomobilski funkcionalno varnostjo
 - Idealna rešitev za nizkonapetostno hibridizacijo komercialnih vozil in traktorjev
- BREZKONTAKTNI ODDAJNIKI**
 - Rešitev za sinhrono motorje brez trajnih magnetov in brez krtlač
 - Visoko učinkoviti oddajnik in motor
- 400V STATOR IN ROTOR ZA POGONE**
 - Stator in rotor za 400V/150kW AC motorje
 - Visoko učinkoviti AC motorji z visokim fill faktorjem in majhno rezo med rotorjem in statorjem

At the bottom of the screen, there are images of a white car and a white truck, with the MAHLE logo to the right.

On the table in the foreground, there are two MAHLE logos.

Kristijan Saksida

Modeliranje konduktivnih motenj

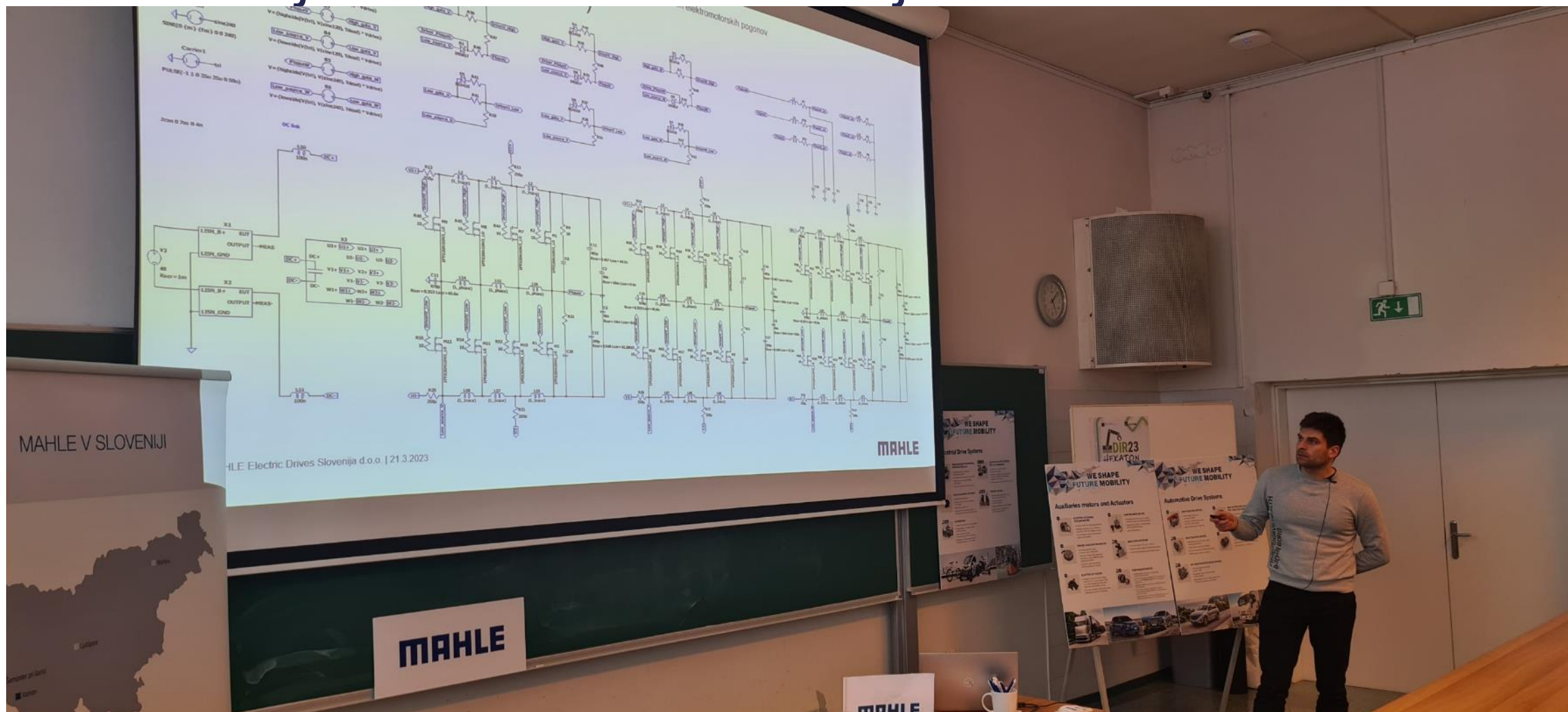
MAHLE

Iris Soban in Tamara Frankovič

Predstavitev zaposlitvenih priložnosti

MAHLE

Tomo Koželjnik in Anton Tihole

Delavnica načrtovanja filtrov

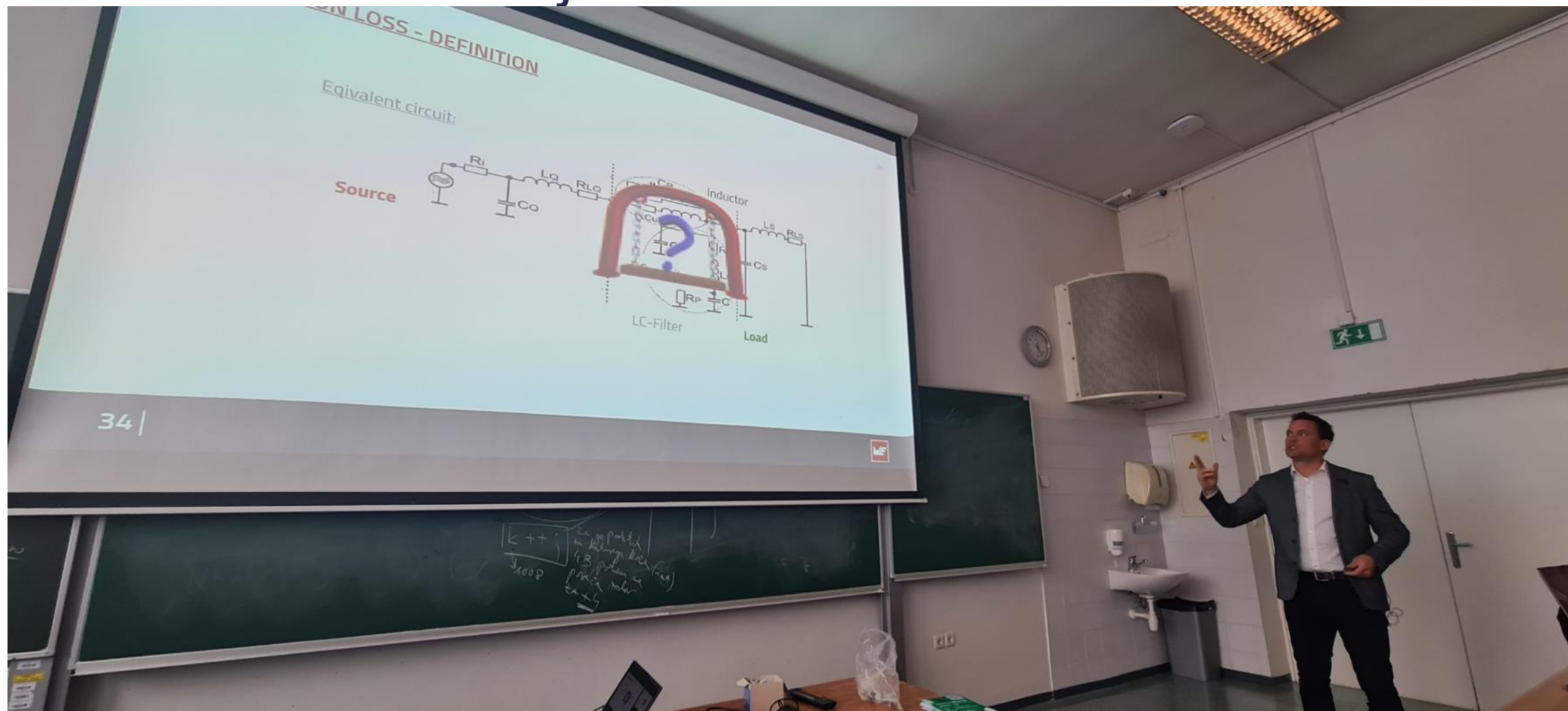

Izhodiščna meritev



Peaks		
frekvenca	amplituda	razlika nad m
26000	99,5	
156750	59,9	9,9
181500	65,24	15,24
208500	56,63	6,63
233250	60,09	10,09
287250	55,62	5,62
543750	40,39	6,39

Napoved amplitud naslednjih korakov

Frekvenca	Amplituda
26000	
181500	
543750	

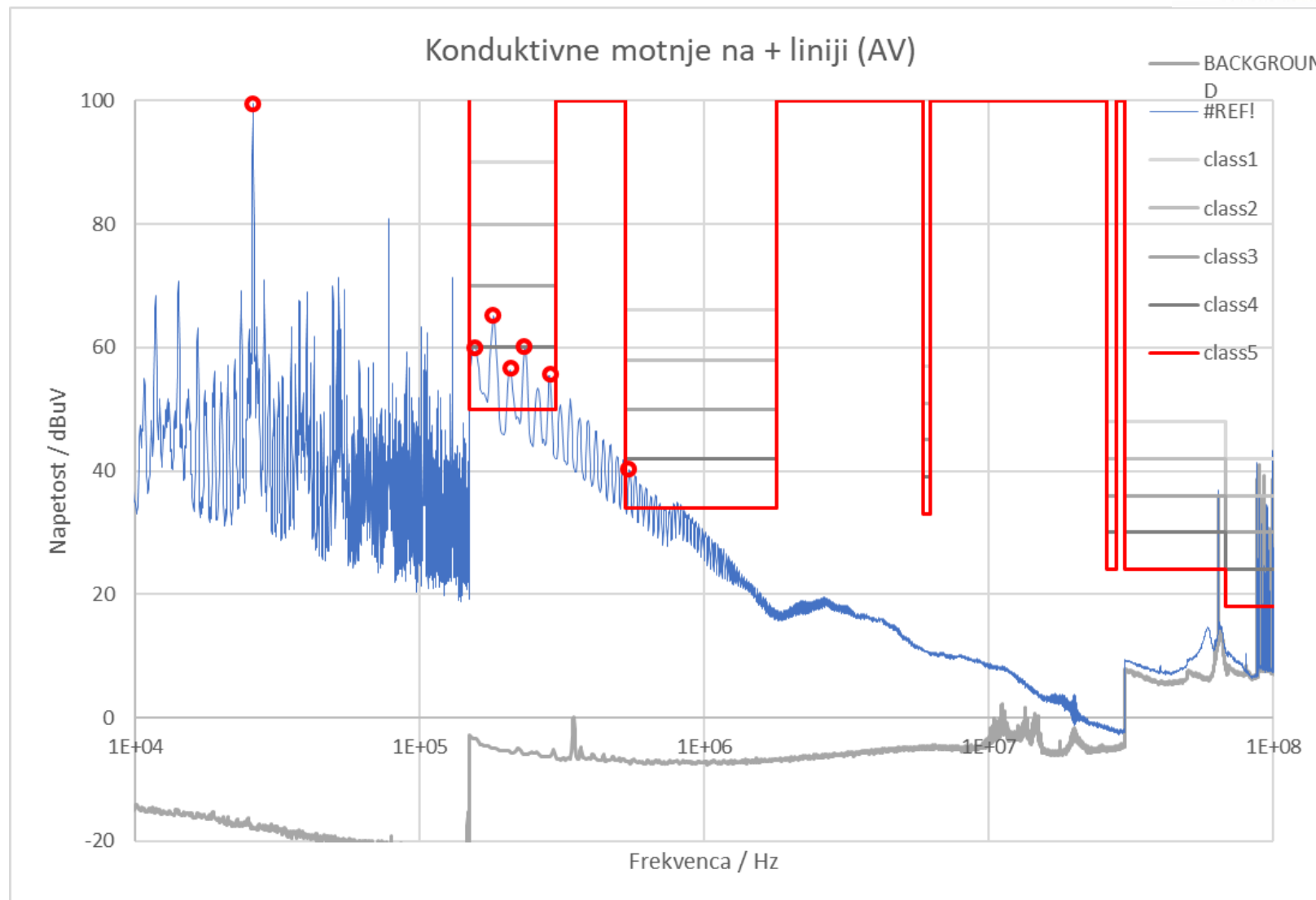

18 oddanih filtrov



Meritve filtrov z WE delavnice

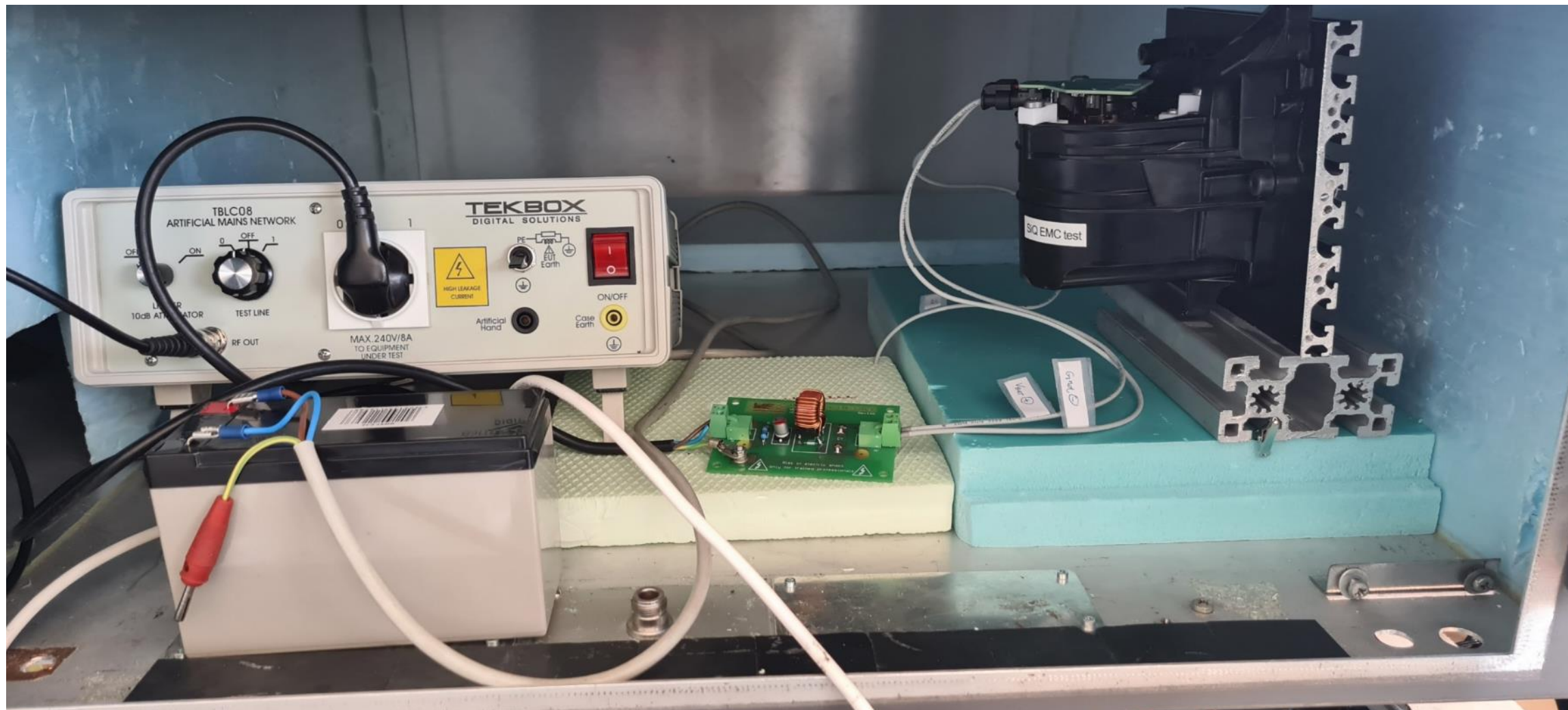

Zmagovalec Matic Rotovnik



Frekvenca	Amplituda	Meritev	Odstopanje
26000	93,00	91,72	1,28
181500	41,00	37,72	3,28
543750	7,00	8,70	-1,7

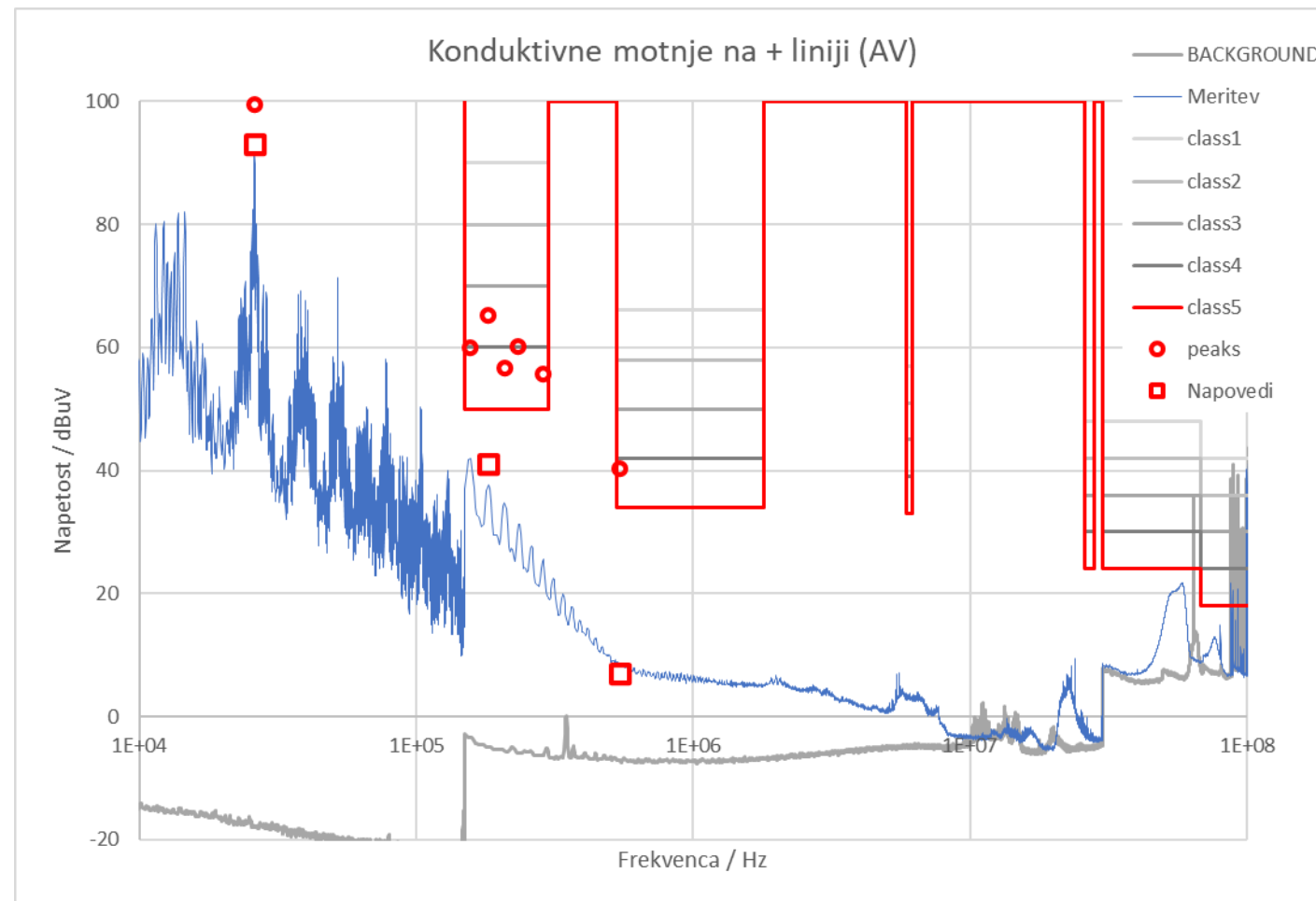
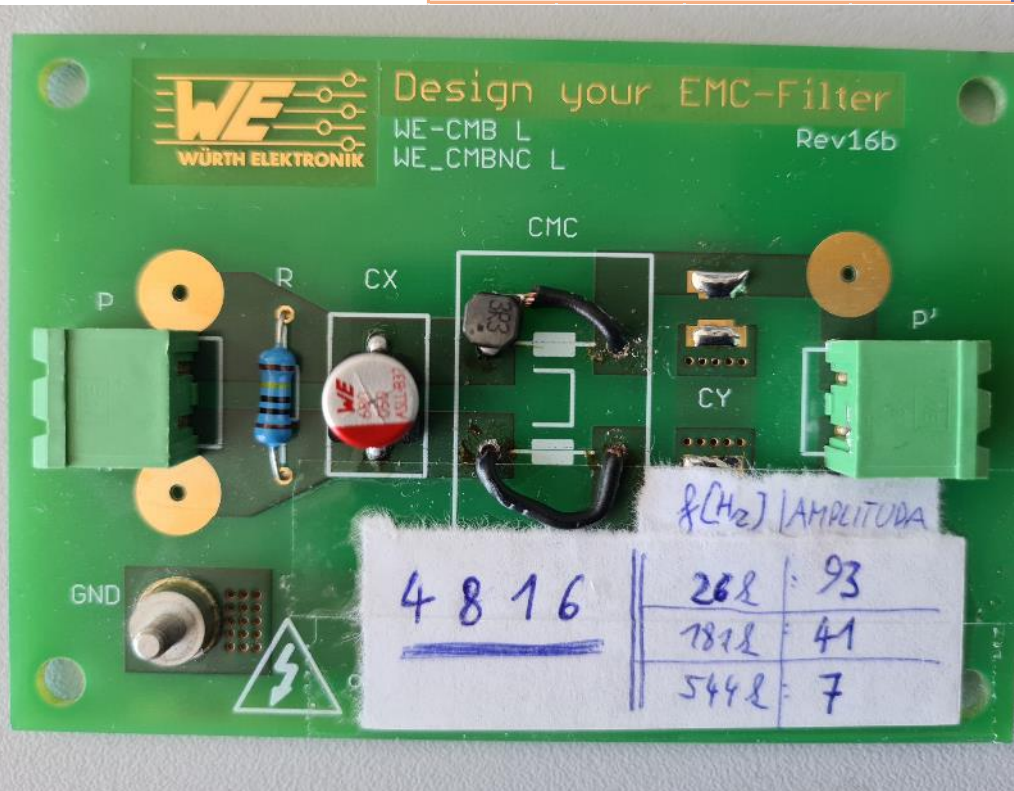

Matija Markovič

Novosti v Altium Designerju

COMPUTER
CONTROLS 

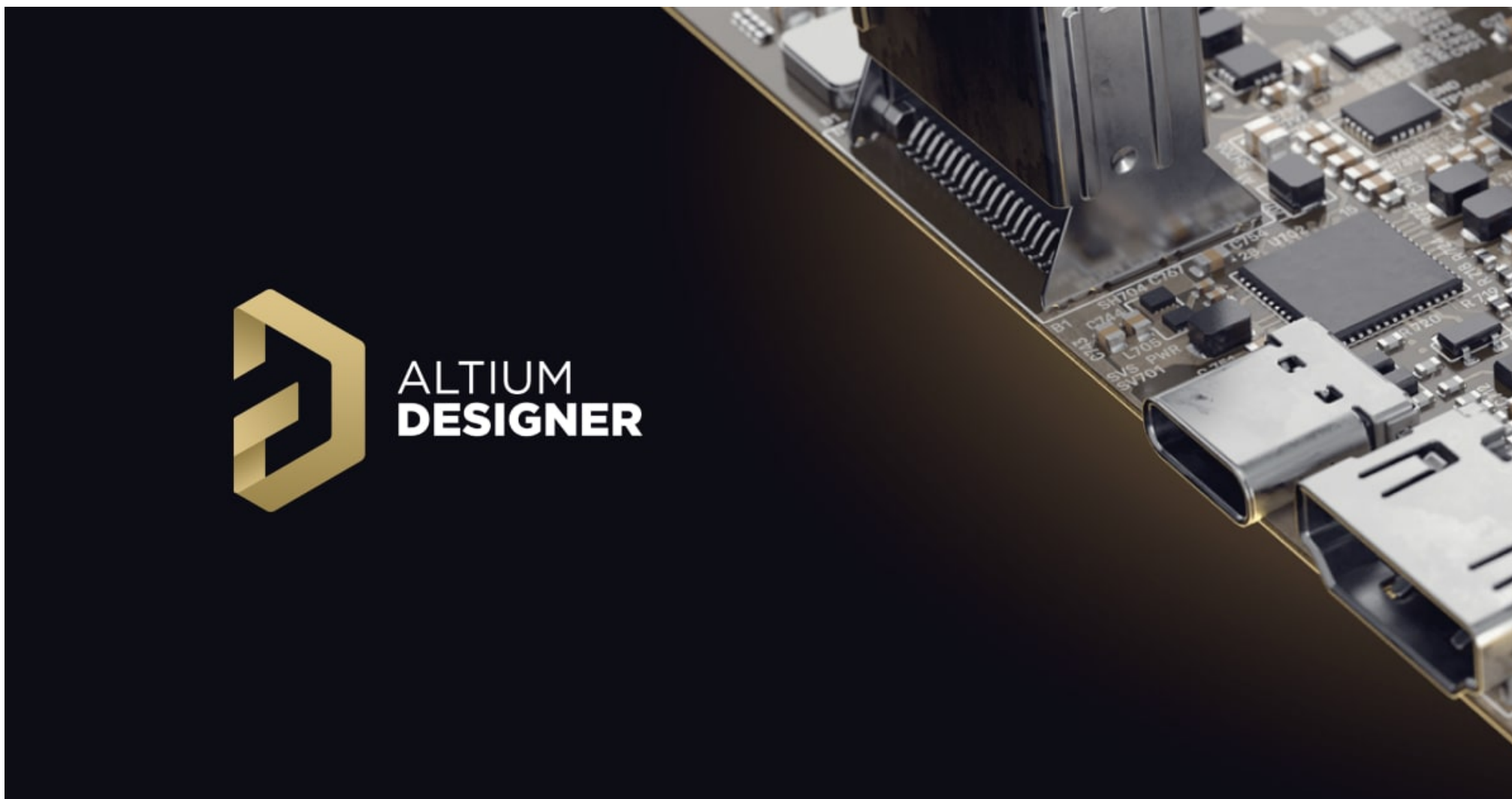

Andrej Krejan

Predstavitev podjetja



Customer revenue share YTD

Product revenue share YTD

Product volume share YTD

10,8 million
Products per year

1,776
Active sales articles

162
Customers worldwide

13 | Company Presentation | HELLA Saturnus Slovenija | Ljubljana, April 2023

FORVIA
Inspiring mobility

Logos: VW, RENAULT, NISSAN, MERCEDES, VOLVO, PSA, PEUGEOT, CITROËN, AUDI, etc.

Jernej Štemberger, Jure Klančar

Dizajn za proizvodnjo v avtomobilski industriji



Pogosti problemi na SMT

Common defects

- > Voiding, solder balls, tombstones...
- > IPC-A-610H class 2/3

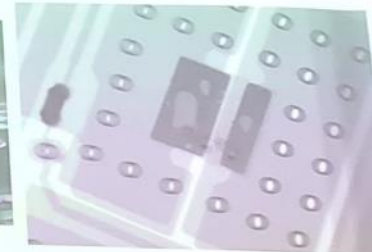
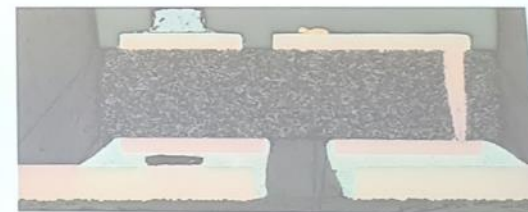

11.4.2023 | Klančar | Dizajn za SMT proizvodnjo

FORVIA
Inspiring mobility

praktični: Cifer (3) →

0	1	1	0	0	0	0	1
1	1	0	1	1	0	1	0
1	1	1	1	0	0	1	0

Anže Šušteršič

Dizajn za proizvodnjo v avtomobilski industriji



Grega goes into stealth mode



Scavenger hunt

FORVIA
HELLA



Obisk Kolektorja v Idriji



Obisk Kolektorja v Idriji

60
YEARS
KOLEKTOR



Obisk Kolektorja v Idriji



Obisk Kolektorja v Idriji

60
YEARS
KOLEKTOR



Programiranje in razhroščevanje vezij

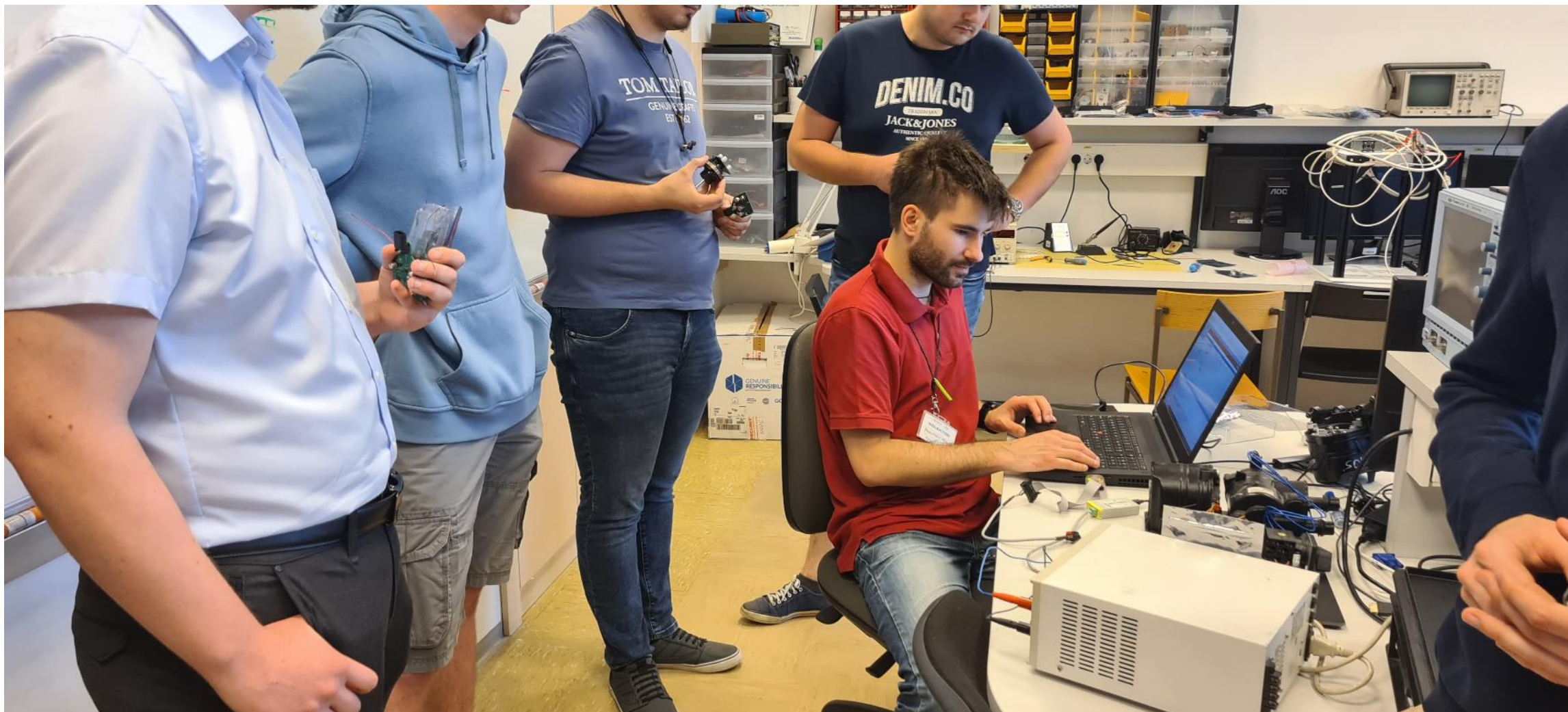

Oddaja projektov



Testiranje delovanja in merjenje električnih parametrov

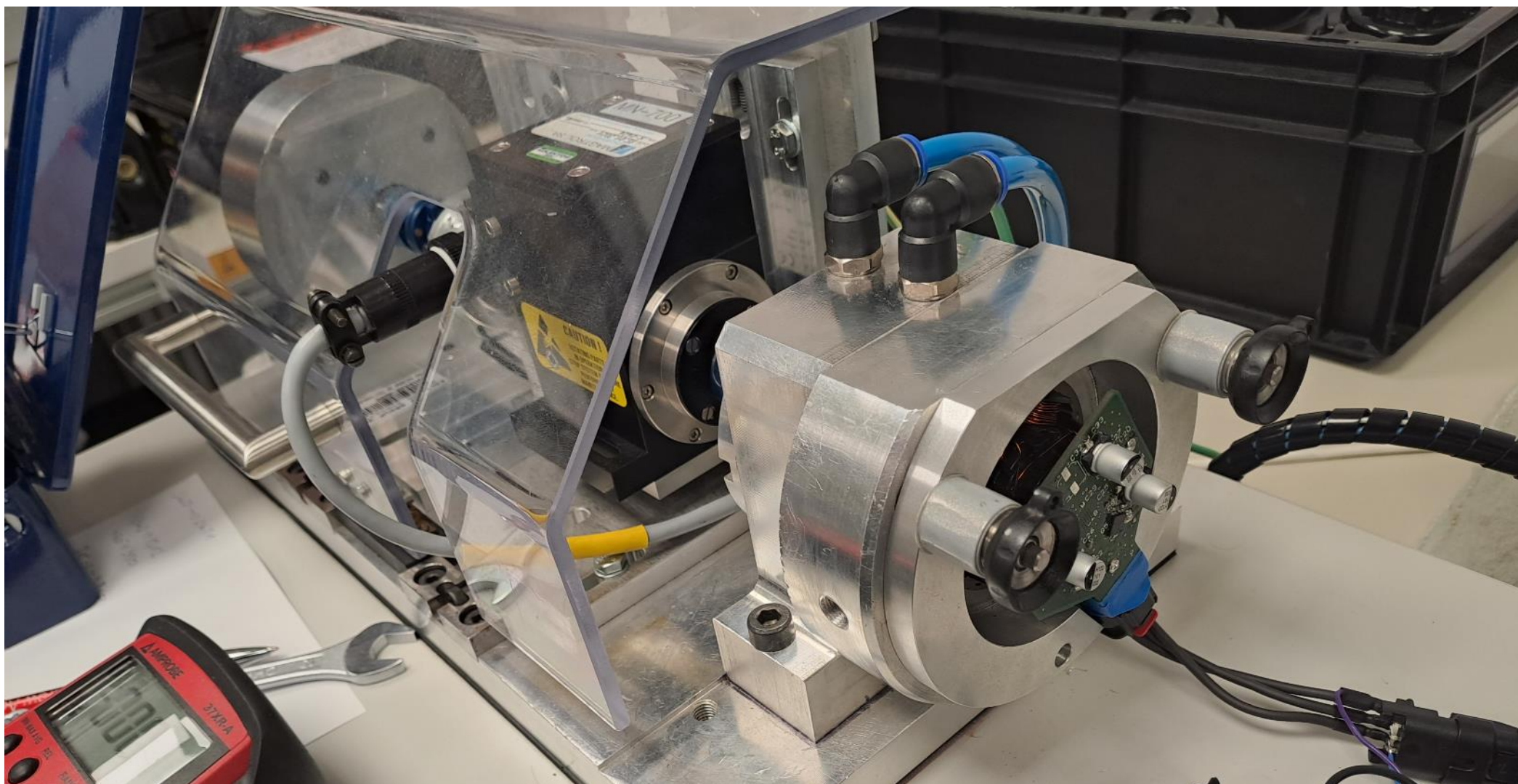

EMC meritve



EMC meritve

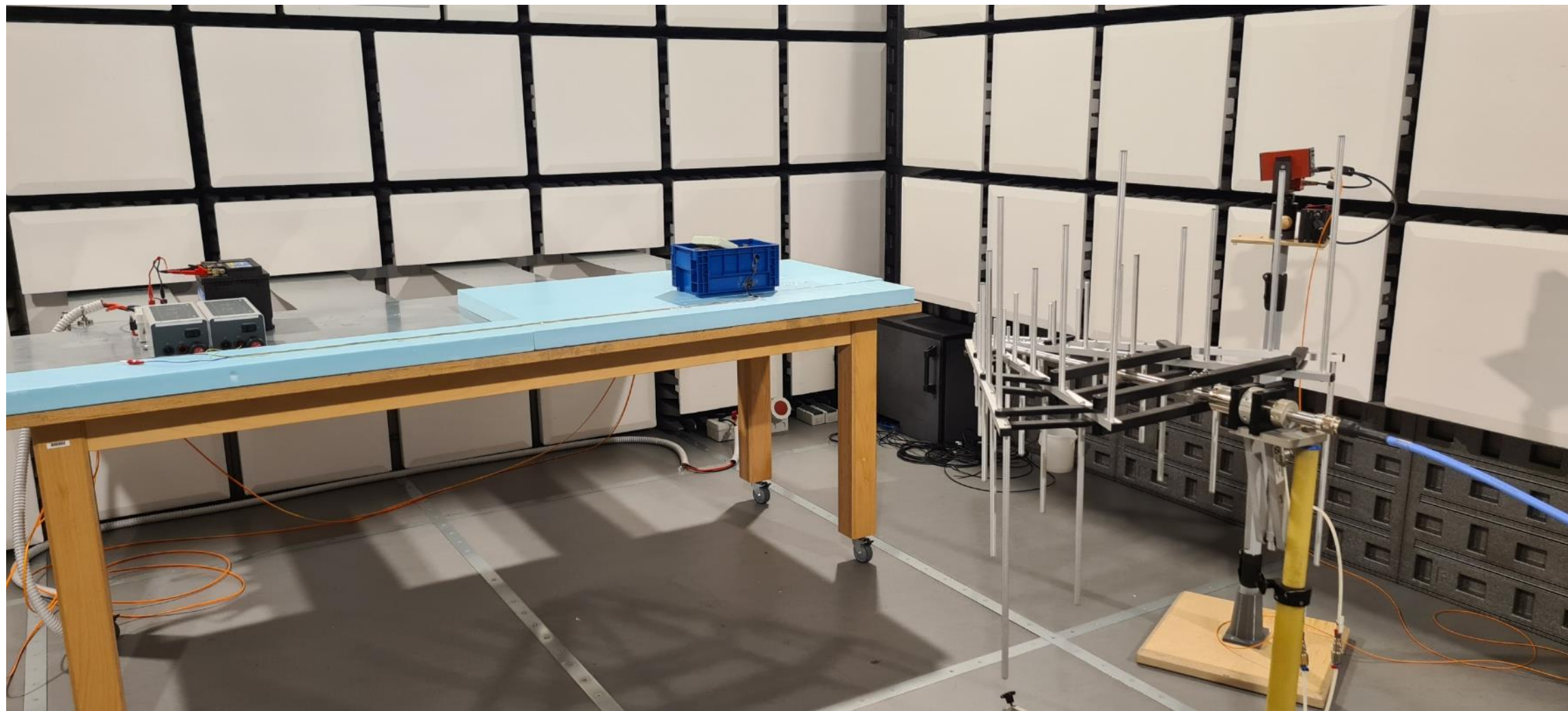

EMC meritve



EMC meritve

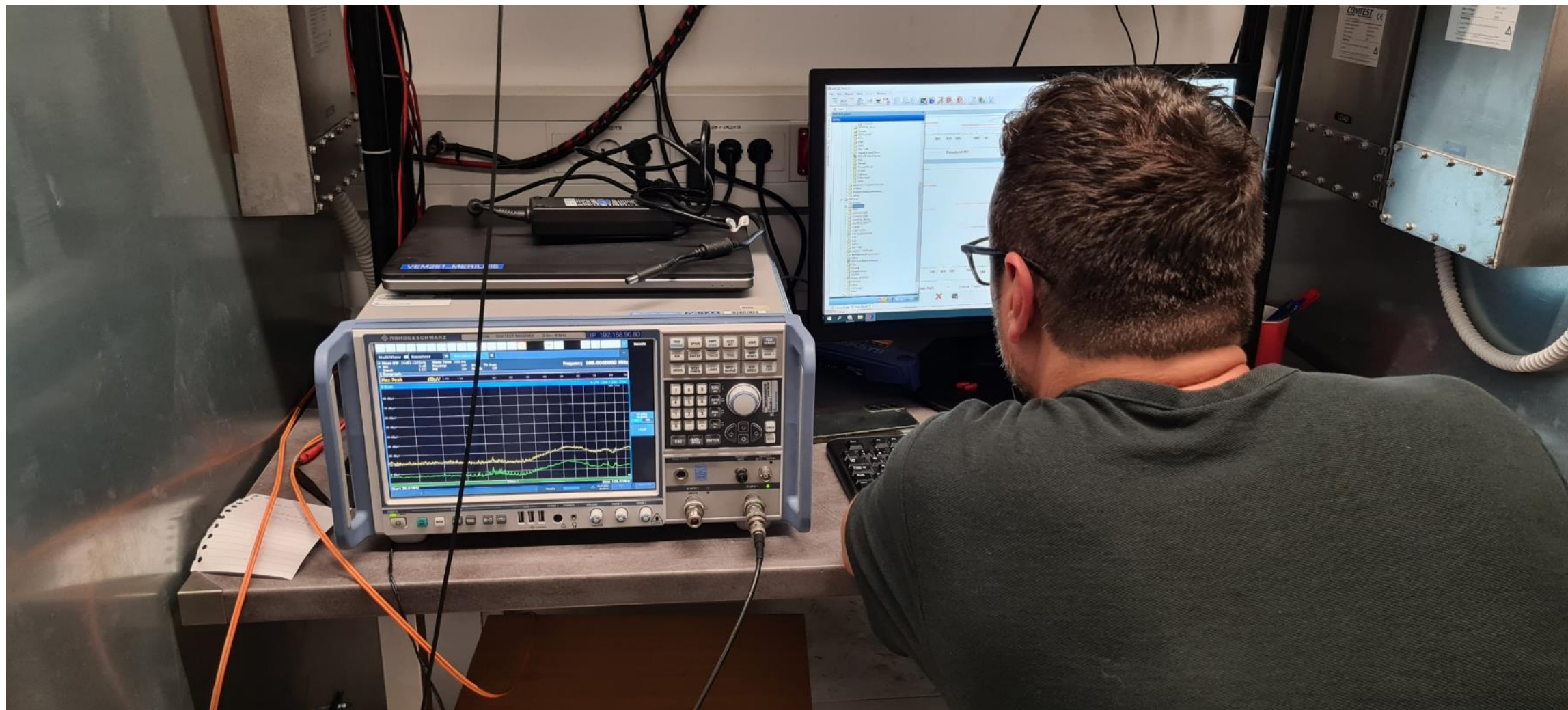

Zadovoljni z rezultati



KOLEKTOR



Osnove tekmovalnega projekta

Tekmovalni projekt

EMC-24827 - Pogon je sestavljen iz vezja, konektorja, statorskega navitja in rotorja. Zunanji gabariti vezja in ključne povezovalne pozicije so določene s priloženim izhodiščnim načrtom tiskanega vezja.

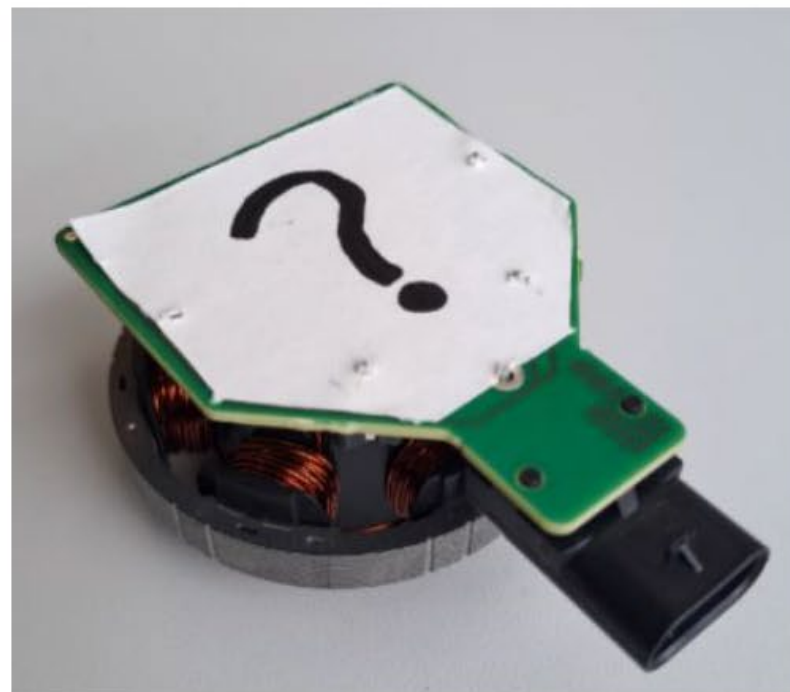

Arhitektura

EMC-24848 - Statična arhitektura vezja mora slediti naslednji shemi:

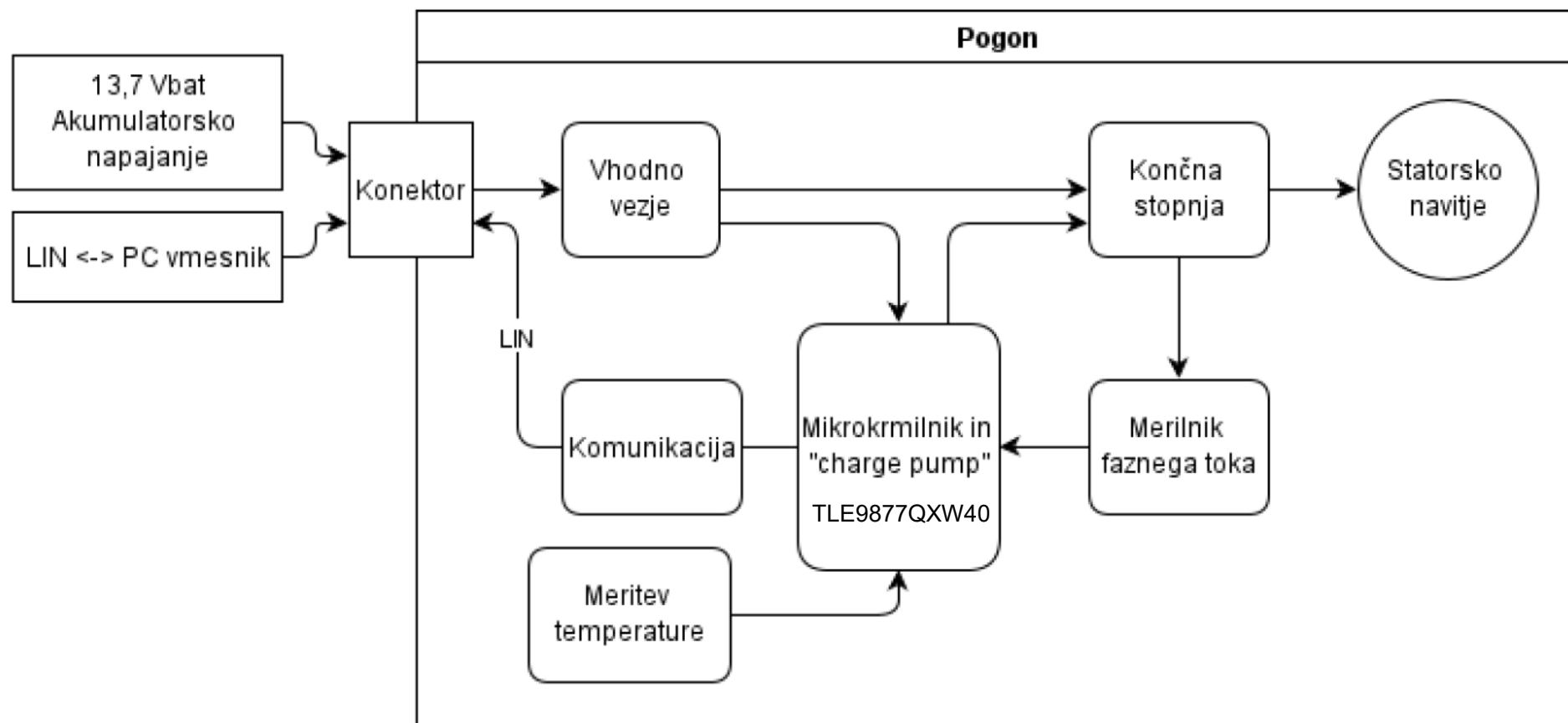

Načrtovalske zahteve

- Aktivne komponente
 - AEC-Q101 kvalificirane
- Vse komponente
 - SMD
 - $T_{max} = 125\text{ °C}$
 - $U_{min} = 30\text{ V}$
- Napetostno območje 8,5V do 16 V
- Amplitude faznih tokov
 - zagon 17 A
 - obratovanje 6 A
- Skupna izgubna moč
- Padec napetosti na vhodnem vezju
- Prenihaj fazne napetosti
- Zaščite
 - Prenapetost
 - Obratna polariteta
- Skladnost s
 - EN55025:2017
 - VW81000:2018 v območju od 9 kHz do 150 kHz.

• Obratovalni profil

EMC-24840 - Med obratovanjem pri nazivni napetosti pričakujemo različne tokovne porabe in trajanja obratovalnih načinov:

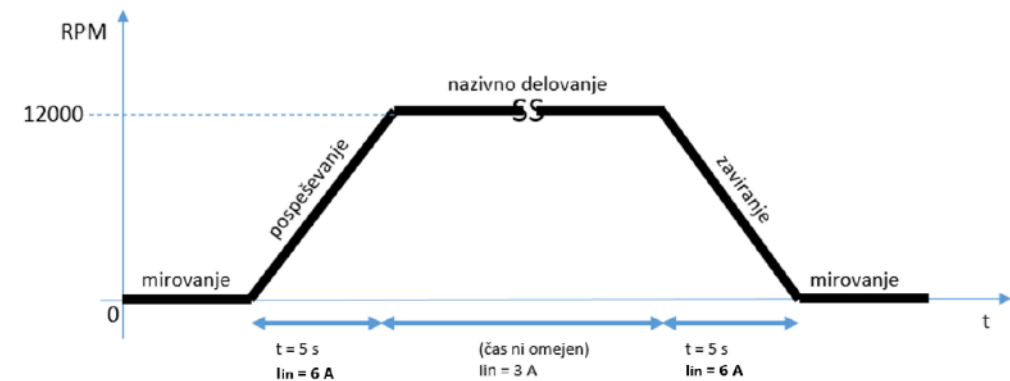

• 4 slojno vezje po predlogi

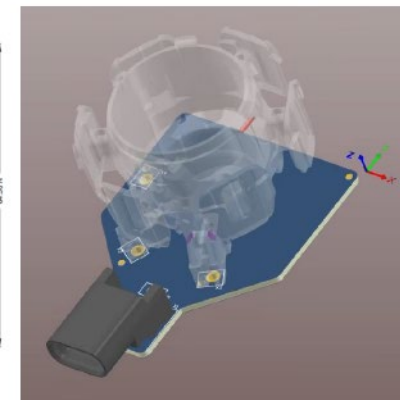
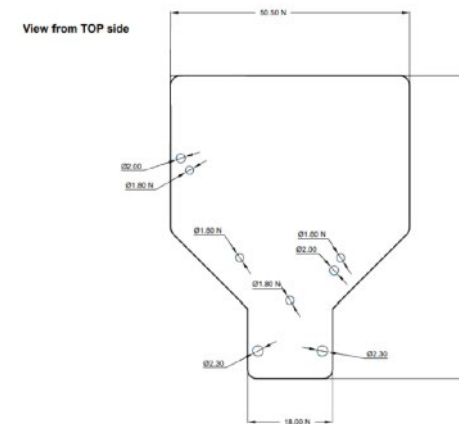

Osnovna shema

vhodni filter

prenapetostna
zaščita

zaščita pred
obratno
polariteto

kondenzatorji za
zalogo naboja -
DCLINK

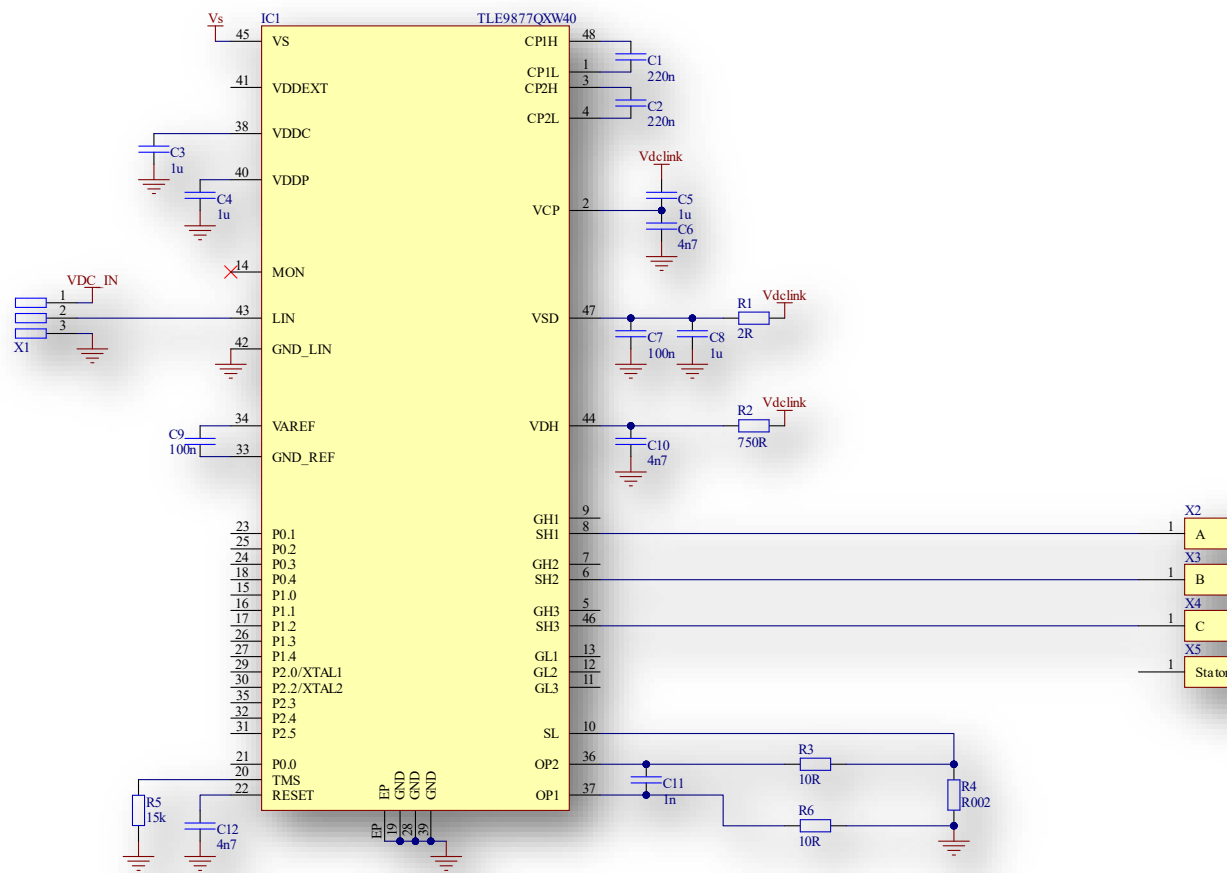

trifazni mostič

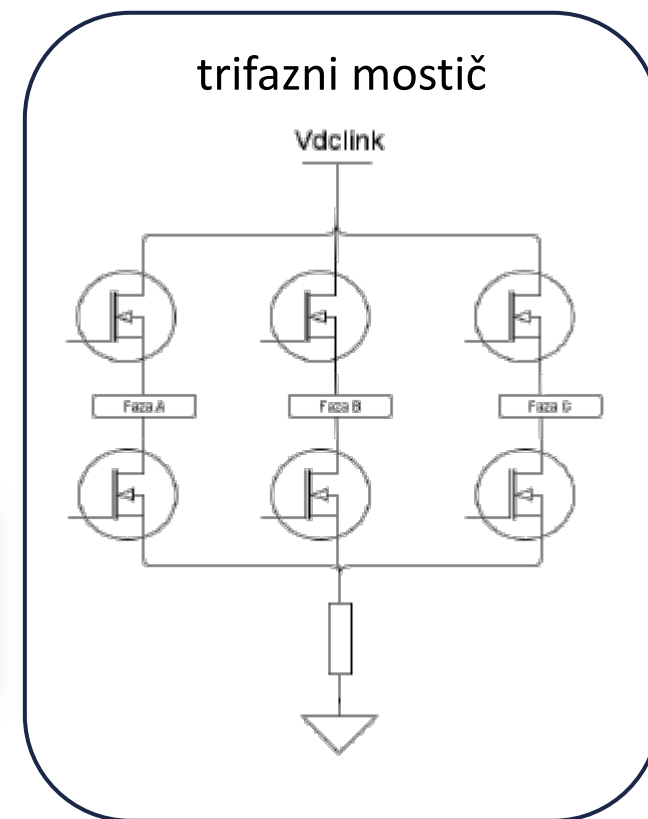

Ocenjevalni kriteriji

EMC-24913 - Pregled 1 - Pregled BOM

Pregled BOM obsega kriterije:

- skladnost z zahtevami o kvalifikaciji komponent,
- skladnost z zahtevanim temperaturnim območjem,
- skladnost z ostalimi zahtevami podanimi v tem dokumentu.

Število točk: 3 točke za vsak izpolnjen kriterij. Skupaj 9.

EMC-24914 - Pregled 2 - Cena aktivnih in filterskih komponent

Med tekmovalci se primerja seštevek cen vseh aktivnih elementov, filtrskih kondenzatorjev, kondenzatorjev končne stopnje ter tuljav v vezju.

Nižja cena pomeni boljši izid oziroma manjši točkovni odbitek.

Cena se izbere na podlagi cene v spletni storitvi Octopart za količino 1000 kos.

Število točk odbitka: cena komponent pomnožena s faktorjem 5.

Ocenjevalni kriteriji

EMC-24915 - Test 1 - Osnovna funkcionalnost

Opis metode: preizkus pogona na namenski testni napravi.

Testni pogoji:

$U_{in} = 9 \div 15 \text{ V}$ s korakom 1 V

$T = 23 \text{ }^{\circ}\text{C}$

Pričakovan rezultat:

- pogon uspešno pospeši do 12000 rpm,
- pogon vzdržuje 12000 rpm 10 minut,
- pogon uspešno zavira do 0 rpm.

Število točk: 2 točki za delovanje v vsakem od napetostnih korakov. Skupaj: 12.

Ocenjevalni kriteriji

EMC-24916 - Test 2 - Izkoristek motorja

Opis metode: preizkus pogona na namenski testni napravi za preverjanje izkoristka.

Testni pogoji:

$U_{in} = 13,7 \text{ V}$

$T = 23 \text{ °C}$

$n = 12000 \text{ rpm}$

Pričakovan rezultat:

izkoristek večji od 80%.

Število točk: razlika med pomerjenim izkoristkom in 80% pomnoženo s faktorjem 2.

$$T = 2(\text{izkoristek} - 80\%)$$

Ocenjevalni kriteriji

EMC-24917 - Test 3 - Odpornost na napačno polariteto

*test je lahko destruktiven zato se na željo tekmovalca izvede po EMC testiranju.

Opis metode: priključitev pogona na negativno napetost.

Testni pogoji:

$U_{in} = -14 \text{ V}$

Trajanje $t = 60 \text{ s}$

$T = 23 \text{ °C}$

Kriterij:

- pogon ne utрпи poškodb,
- vhodni tok pri testni napetosti ne preseže 5 mA,
- pogon po vzpostavitvi nazivne napetosti deluje.

Število točk **5.**

Ocenjevalni kriteriji

EMC-24918 - Test 4 - Odpornost na prenapetost

*test je lahko destruktiven zato se na željo tekmovalca izvede po EMC testiranju.

Opis metode: preizkus pogona na namenski testni napravi za preverjanje odpornosti na prenapetost.

Testni pogoji:

$U_{in} = 13,7 \text{ V}$

$n = 12000 \text{ rpm}$

Prenapetost $U_{inp} = 42 \text{ V}$

Upornost vira prenapetosti $R_{in} = 2 \text{ Ohm}$

Trajanje U_{inp} (pravokotni pulz) $t = 100 \text{ ms}$

Število pulzov: 10

Razmik med pulzi $t_r = 30 \text{ s}$

$T = 23 \text{ °C}$

Kriterij:

- pogon ne utрпи poškodb,
- pogon po končanem testu deluje.

Število točk: 5

Ocenjevalni kriteriji

EMC-24919 - Test 5 - Moč in padec napetosti na vhodnem vezju

Opis metode: preizkus pogona na namenski testni napravi. Meritev padcev napetosti na vhodnem vezju in preverjanje izgubne moči.

Testni pogoji:

$U_{in} = 13,7 \text{ V}$

$T = 23 \text{ °C}$

$n = 12000 \text{ rpm}$

Kriterij:

- padec napetosti na vhodnem delu vezja med konektorjem in končno stopnjo mora biti med nazivnim obratovanjem manjši od 200 mV,
- skupna moč izgub na vhodnem vezju ne presega 0,7 W.

Število točk **5.**

Ocenjevalni kriteriji

EMC-24920 - Test 6 - Meritev prenihaja faznih napetosti

Opis metode: preizkus pogona na namenski testni napravi. Meritev faznih napetosti z osciloskopom.

Testni pogoji:

$U_{in} = 13,7 \text{ V}$

$T = 23 \text{ °C}$

OP1 = pospeševanje

OP2 = 12000 rpm

Pričakovan rezultat:

Prenihaj (ali oscilacija) faznih napetosti ne sme presegati $\pm 3 \text{ V}$.

Število točk: 5

Ocenjevalni kriteriji

EMC-24921 - Test 7 - Prevodne napetostne emisij

Opis metode: meritve prevodnih napetostnih emisij po EN55025:2017.

Testni pogoji:

$U_{in} = 13,7 \text{ V}$

$T = 23 \text{ °C}$

$n = 12000 \text{ rpm}$

Število točk glede na dosego razreda:

- Class 1 : 0
- Class 2 : 5
- Class 3 : 10
- Class 4 : 20
- Class 5 : 35

Ocenjevalni kriteriji

EMC-24922 - Test 8 - Sevalne emisije EN55025

Opis metode: meritve sevalnih emisij po EN55025:2017.

Testni pogoji:

$U_{in} = 13,7 \text{ V}$

$T = 23 \text{ °C}$

$n = 12000 \text{ rpm}$

Število točk glede na doseganje razreda:

- Class 1 : 0
- Class 2 : 5
- Class 3 : 10
- Class 4 : 20
- Class 5 : 35

Ocenjevalni kriteriji

EMC-24923 - Test 9 - Sevalne emisije VW TL81000

Opis metode: meritve sevalnih emisij po VW TL81000:2018.

Testni pogoji:

$U_{in} = 13,7 \text{ V}$

$T = 23 \text{ °C}$

$n = 12000 \text{ rpm}$

Število točk glede na doseganje razreda:

- Class 3 : 3

- Class 4 : 6

- Class 5 : 9

Predstavitve oddanih projektov

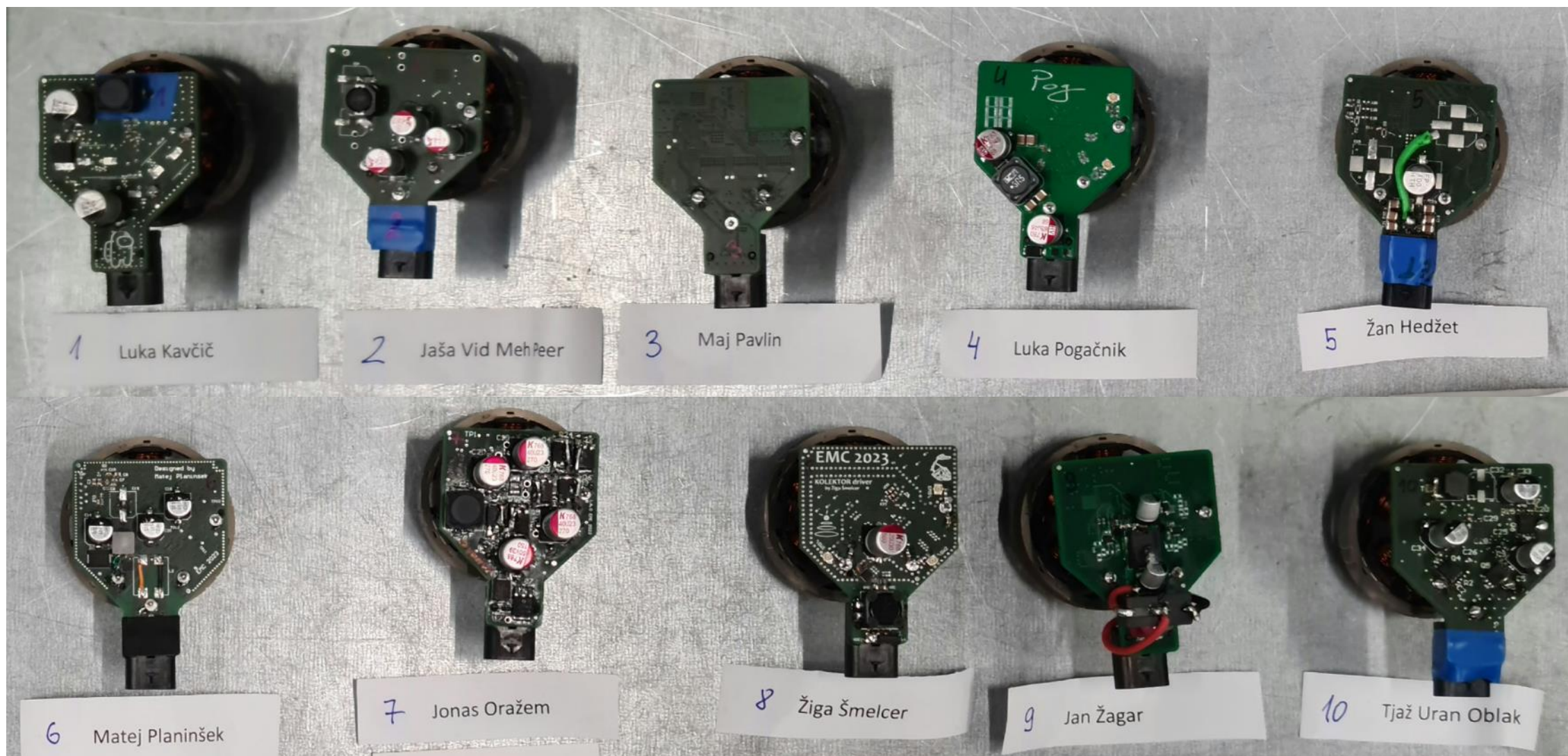

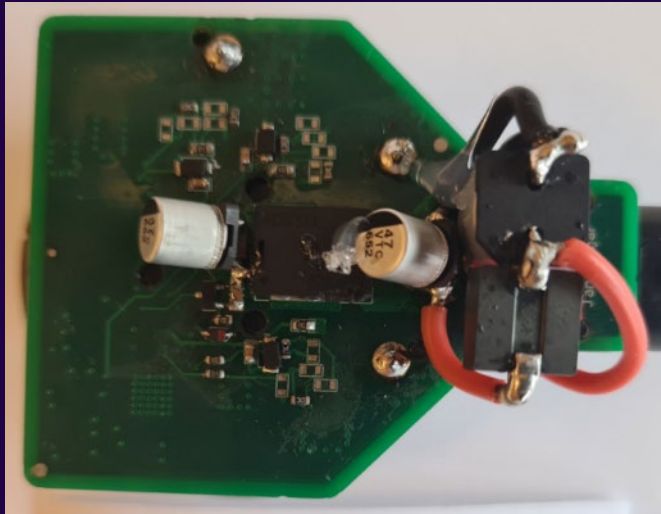

KOLEKTOR



Predstavitev

Jan Žagar

Shema – vhodni filter

△ OPOMBA:

1. VHODNI FILTER JE IZVEDEN V ZRAKU

△

OPOMBA:

2. VHODNI FILTER JE NAREJEN NA PCB-JU

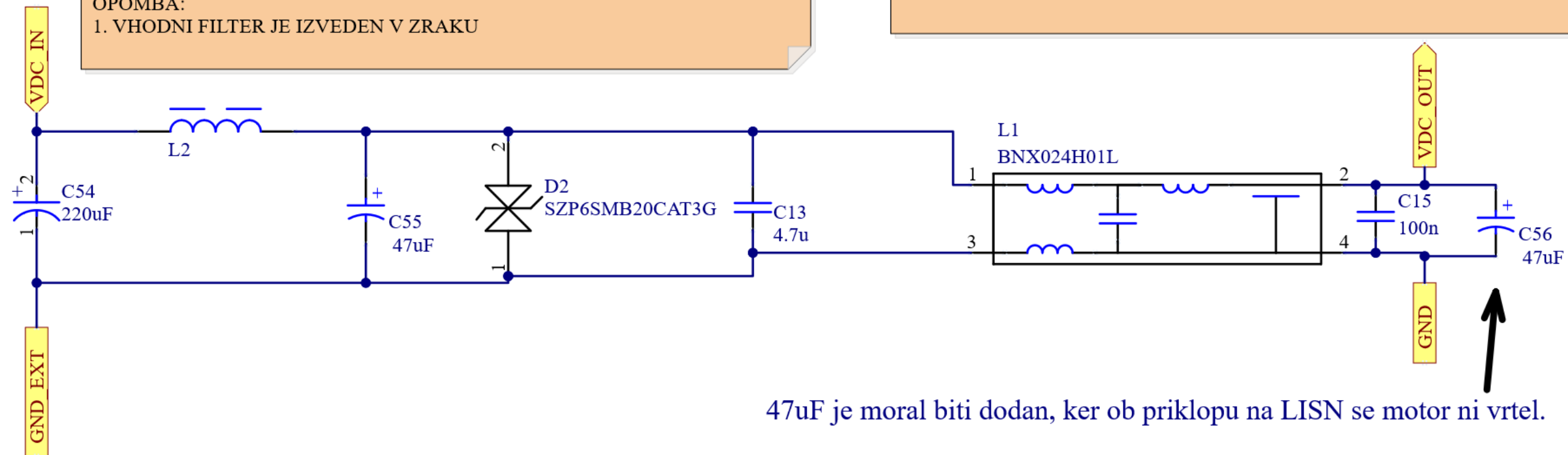

47uF je moral biti dodan, ker ob priklopu na LISN se motor ni vrtel.

Shema – zaščita proti obratni polariteti

Prvotna ideja zaščite

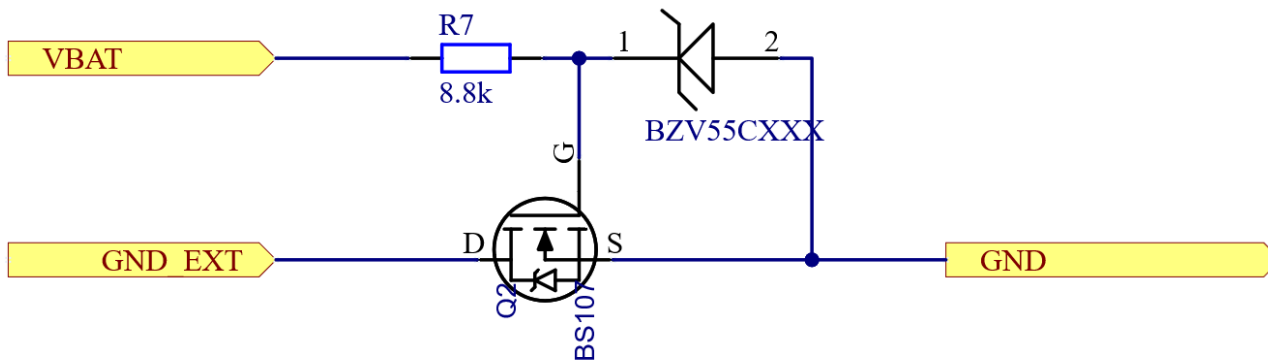

Izvedena zaščita

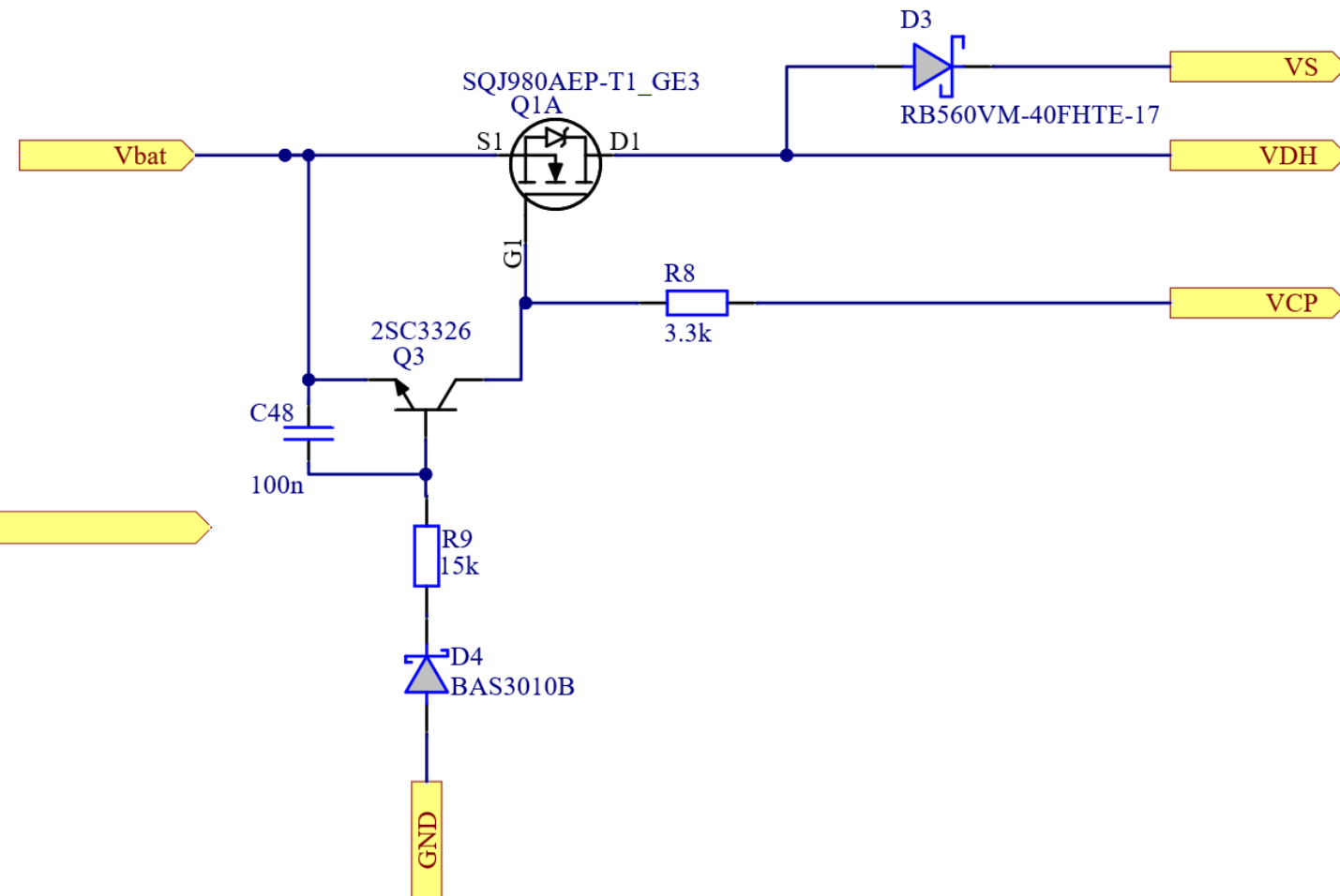

Shema – Povezava kovinskega dela motorja

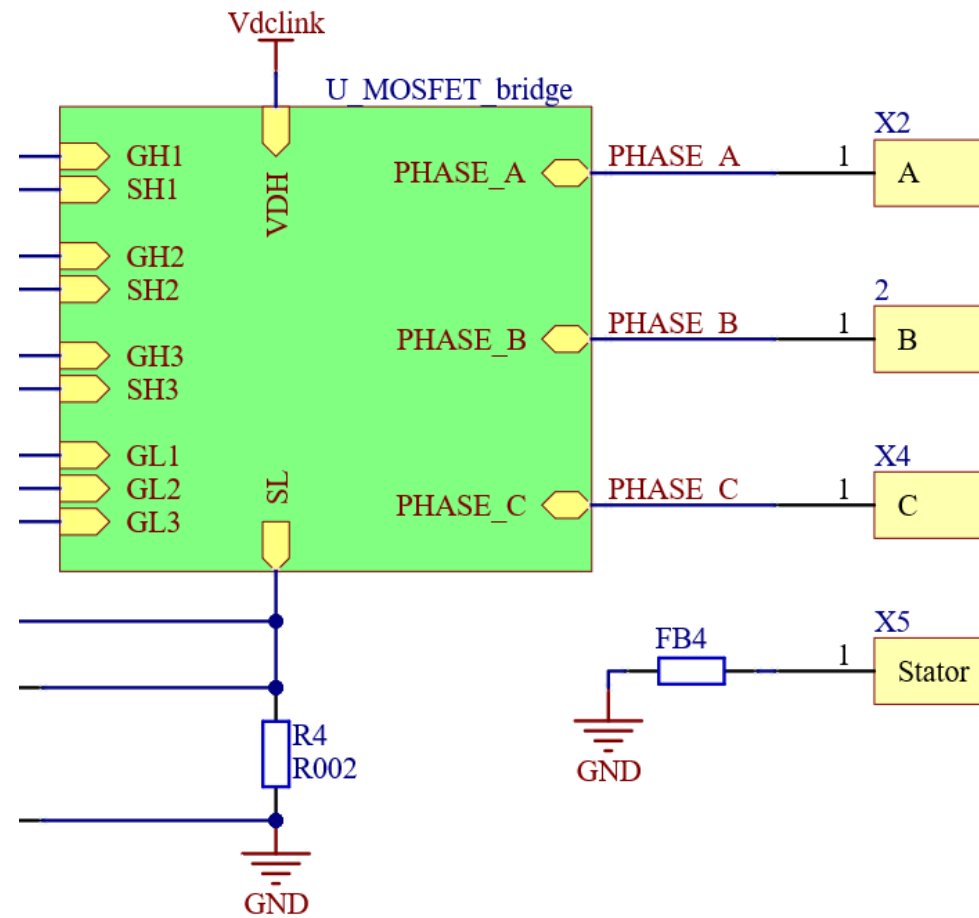

Shema – dušilno vezje

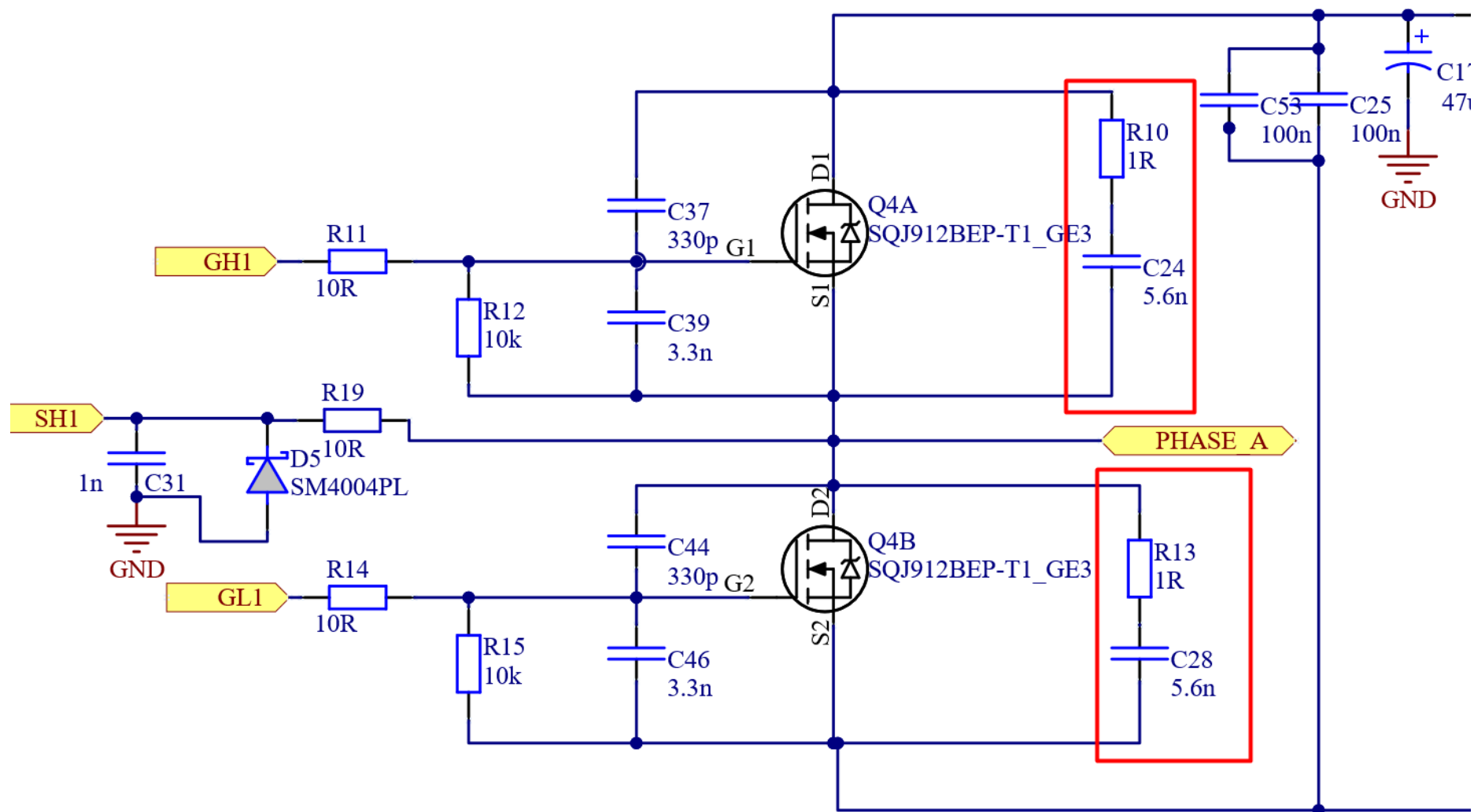

Meritev – preklopov MOSFET-a na fazi

Brez dušilnega vezja

Z dušilnim vezjem



Načrt tiskanega vezja - plasti

1. sloj – signalne / močnostne linije
2. sloj – masa (GND)
3. sloj – napajanje (VCC)
4. sloj – signalne / močnostne linije

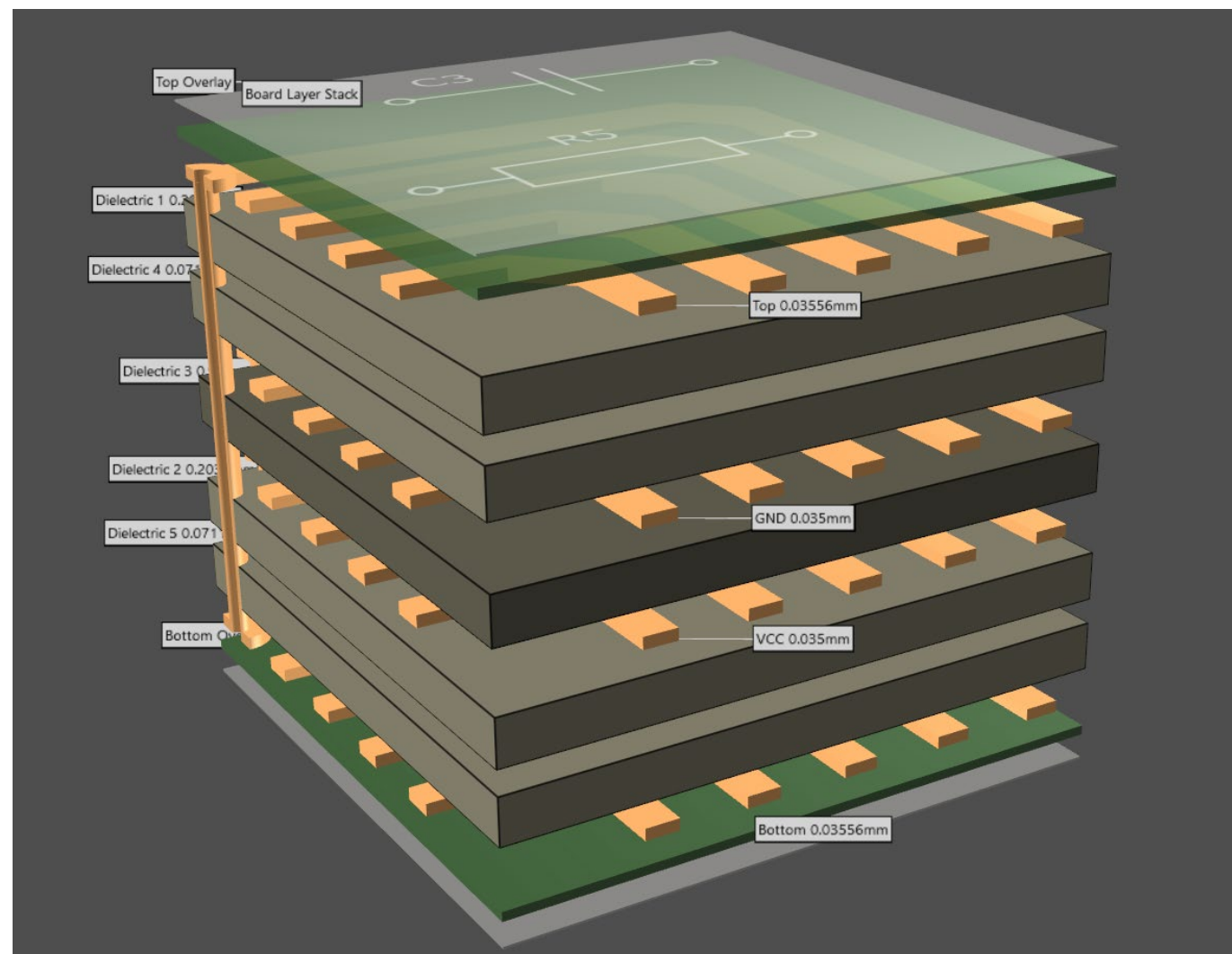

Načrt tiskanega vezja postavitvev komponent

Spodnja stran tiskanine

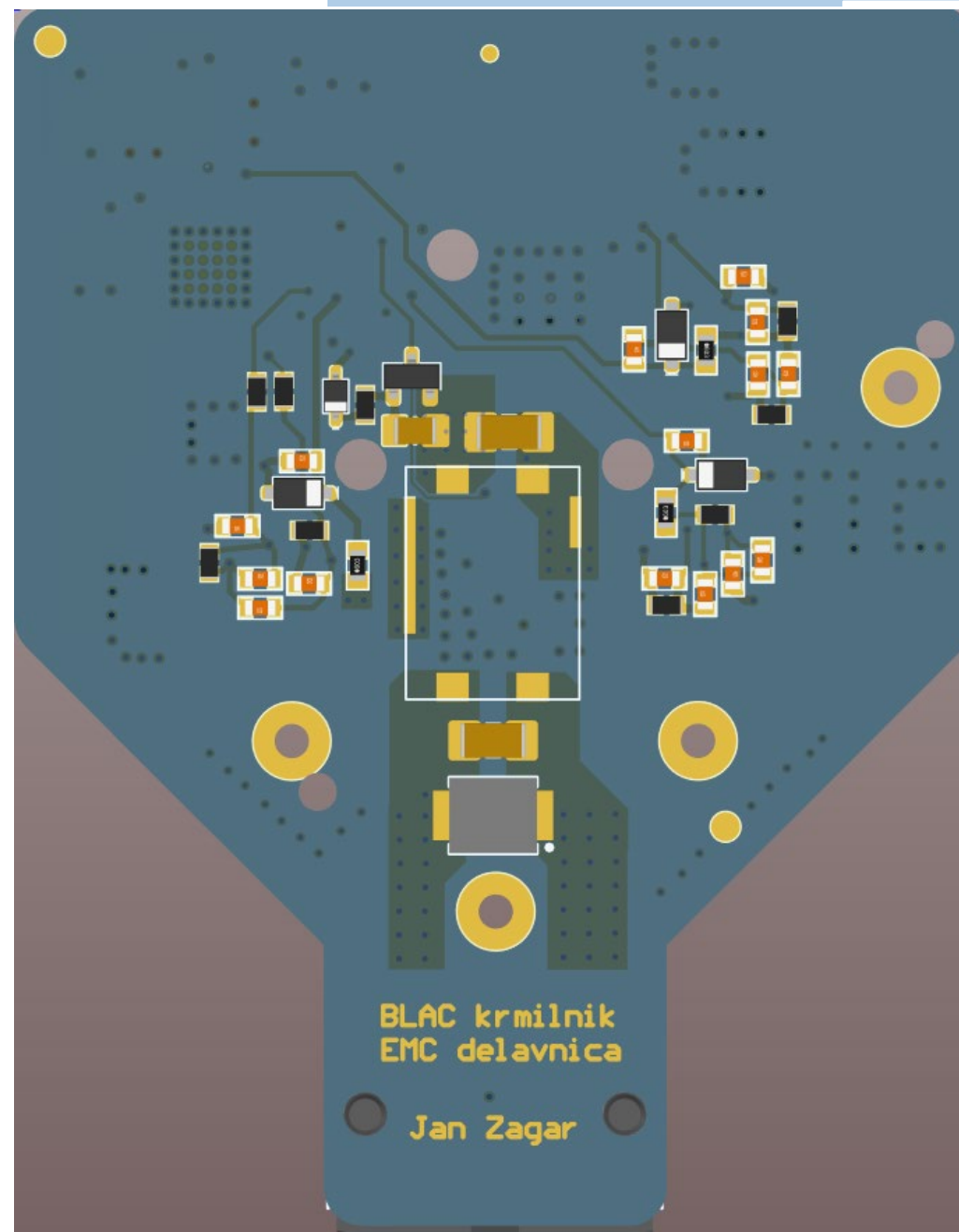

Načrt tiskanega vezja postavitev komponent

zgornja stran tiskanine

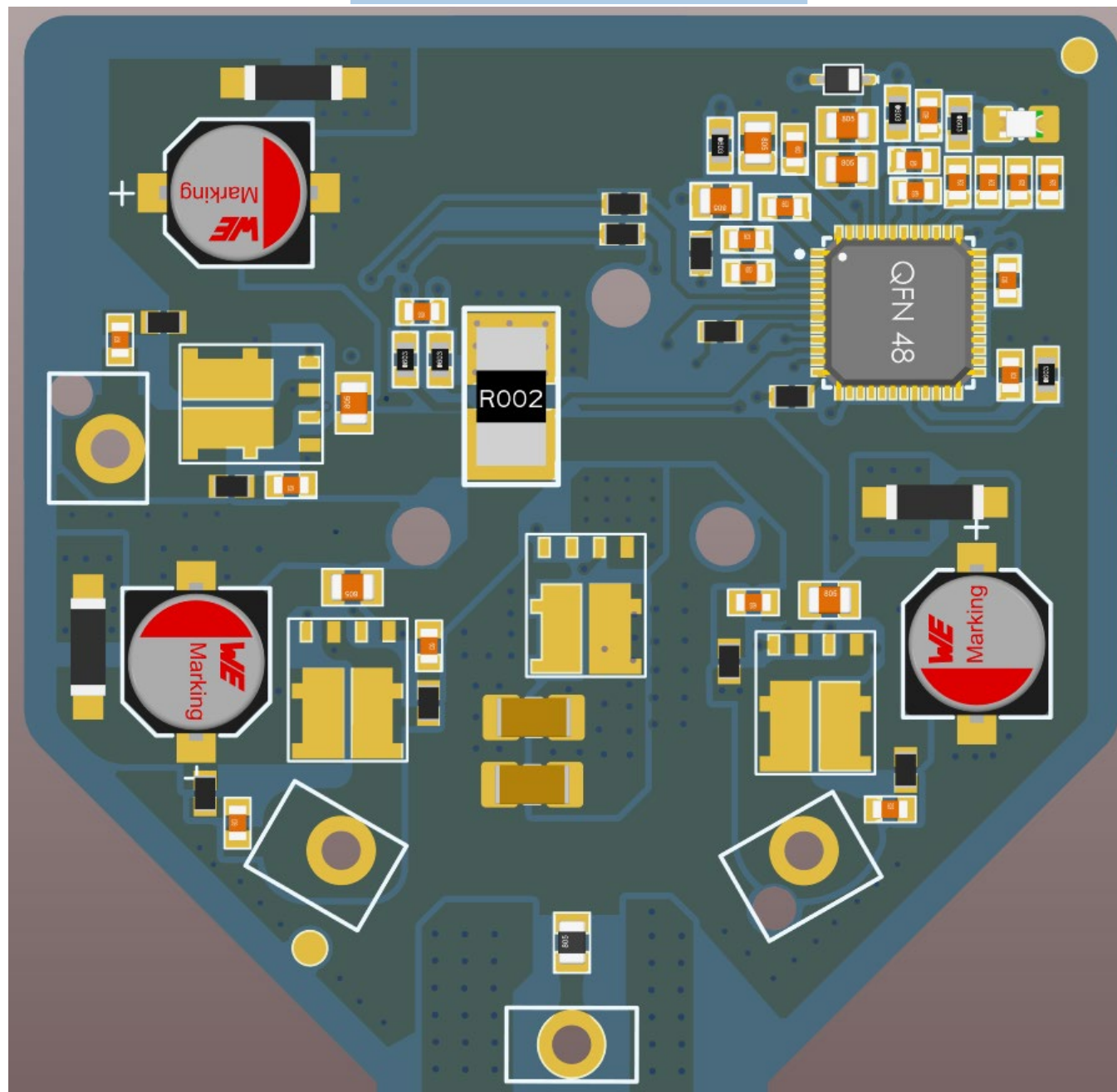

Preliminarne meritve - sevalne

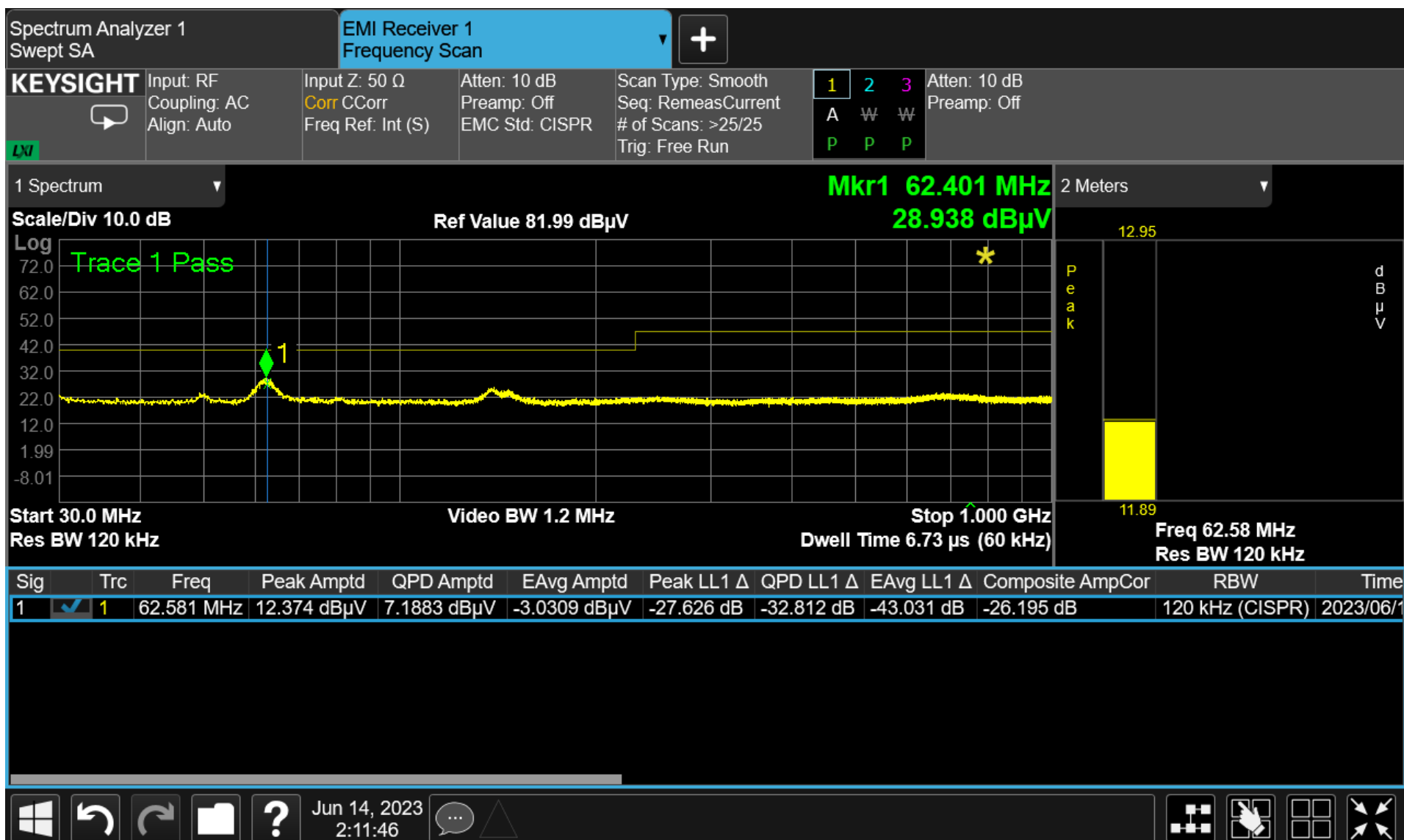

Preliminarne meritve - konduktivne

- Meritve z dvostopenjskim filtrom ----->
- Z filtrom BNX024 je padlo pod limito šele pri cca. 1 MHz

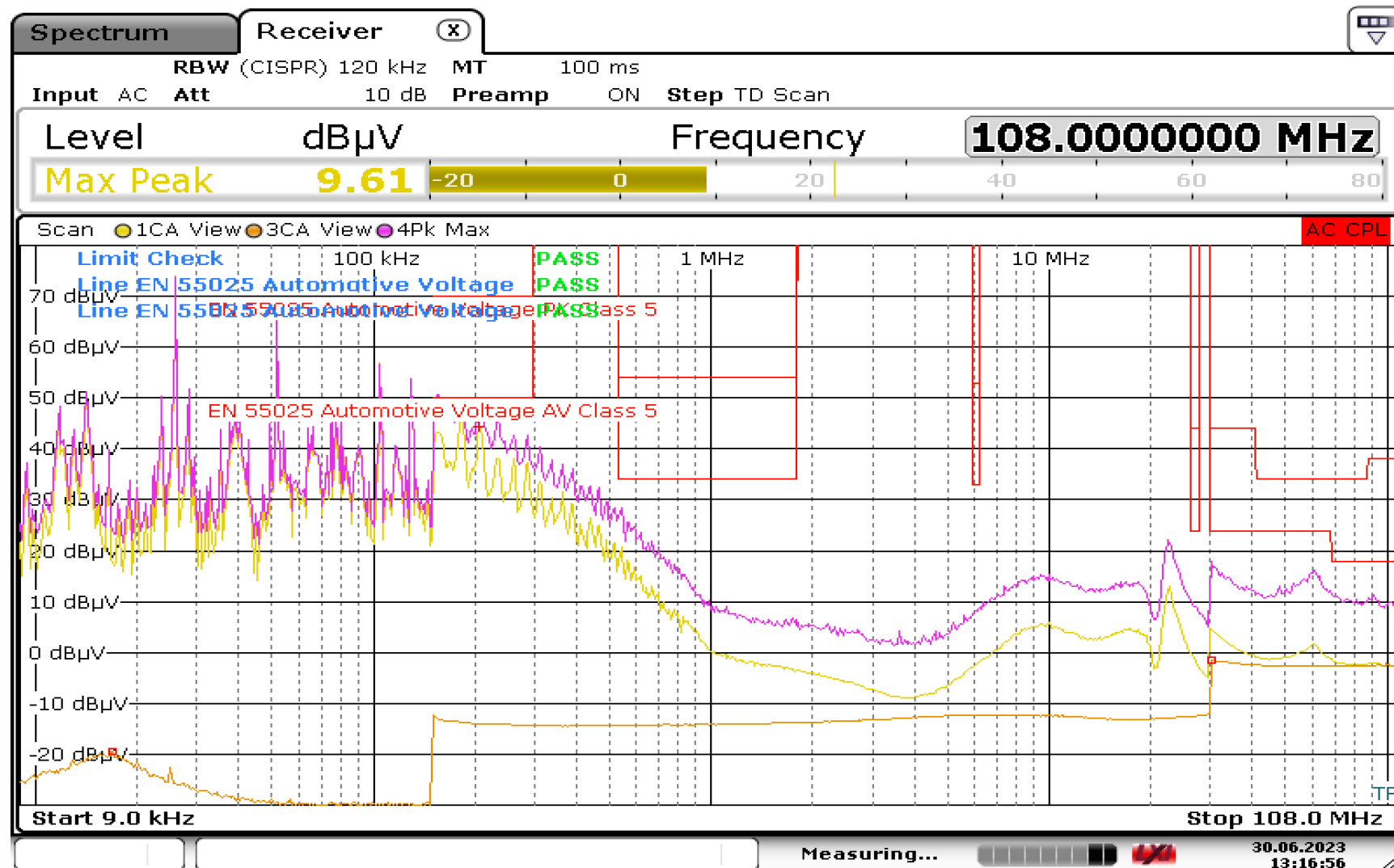

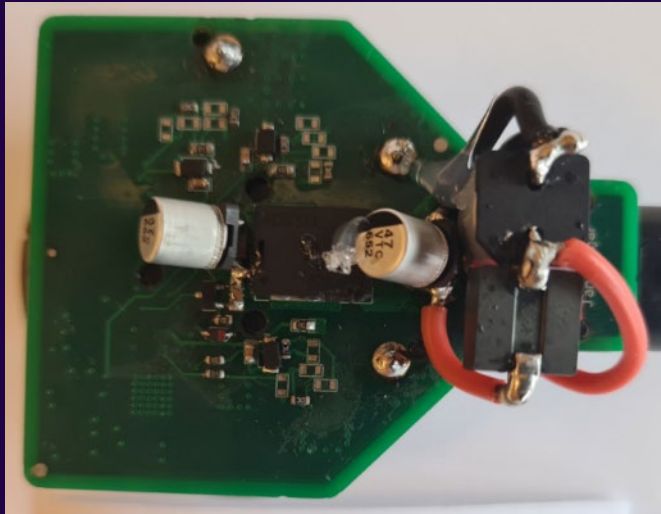

KOLEKTOR



Rezultati

Jan Žagar

Jan Žagar

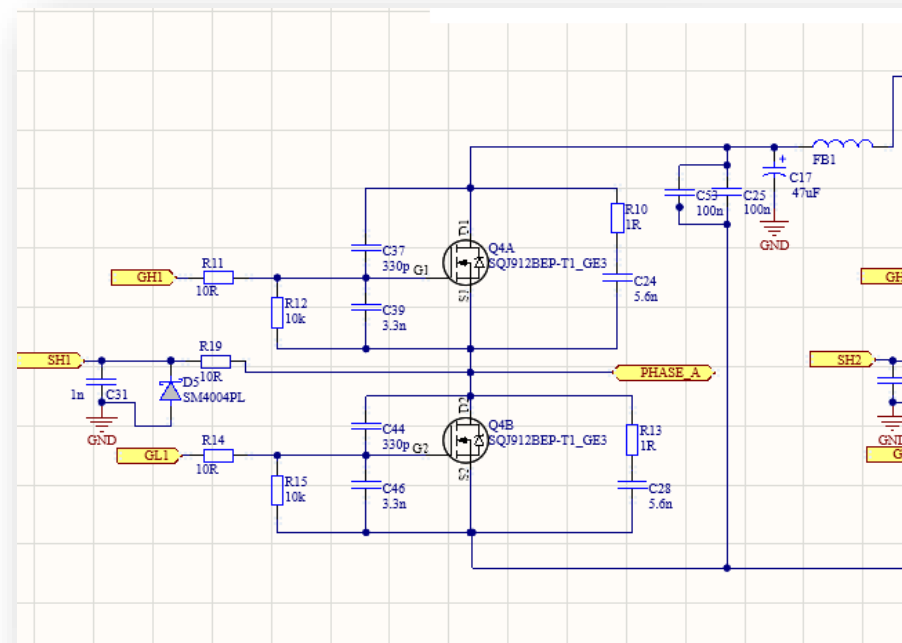
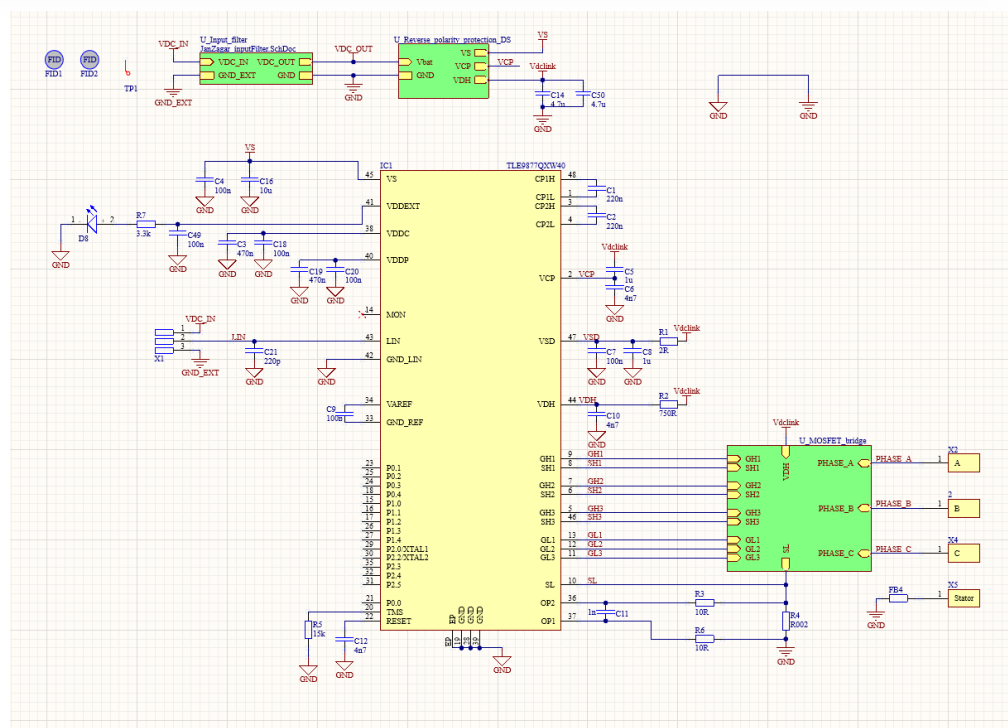
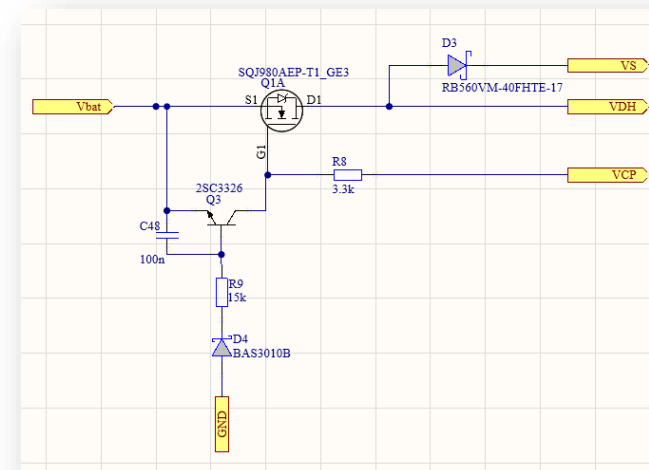
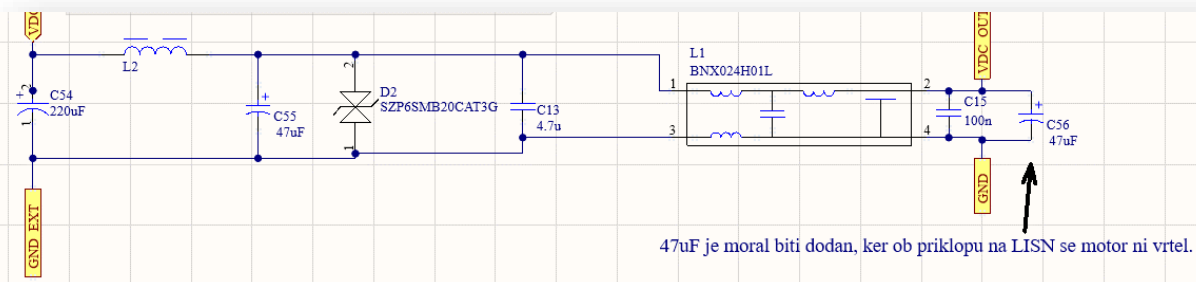

Jan Žagar

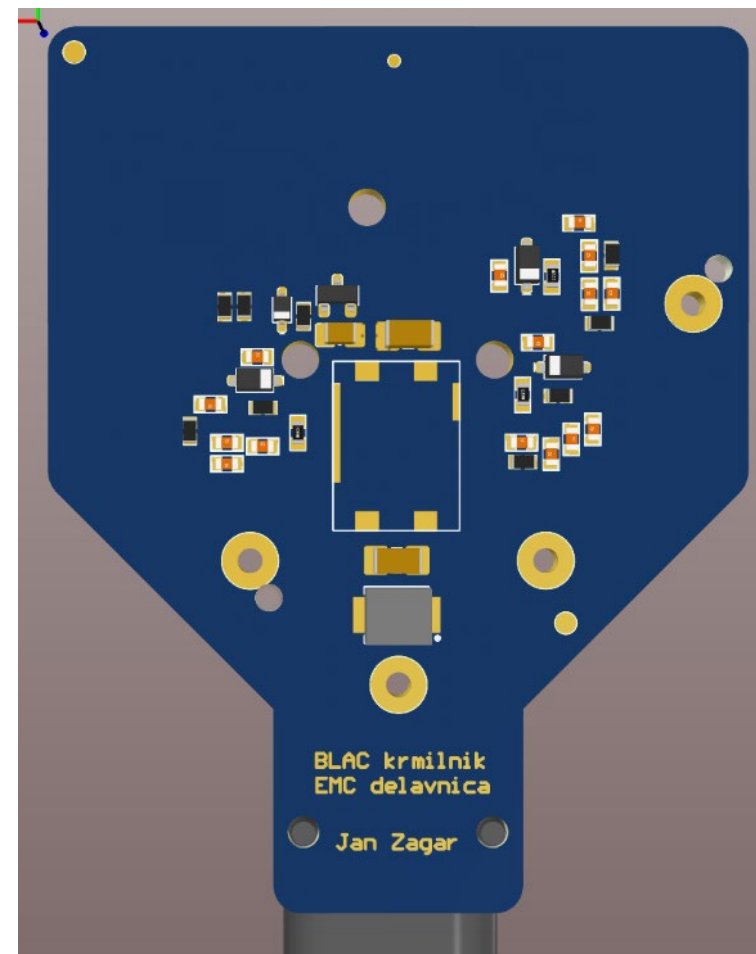
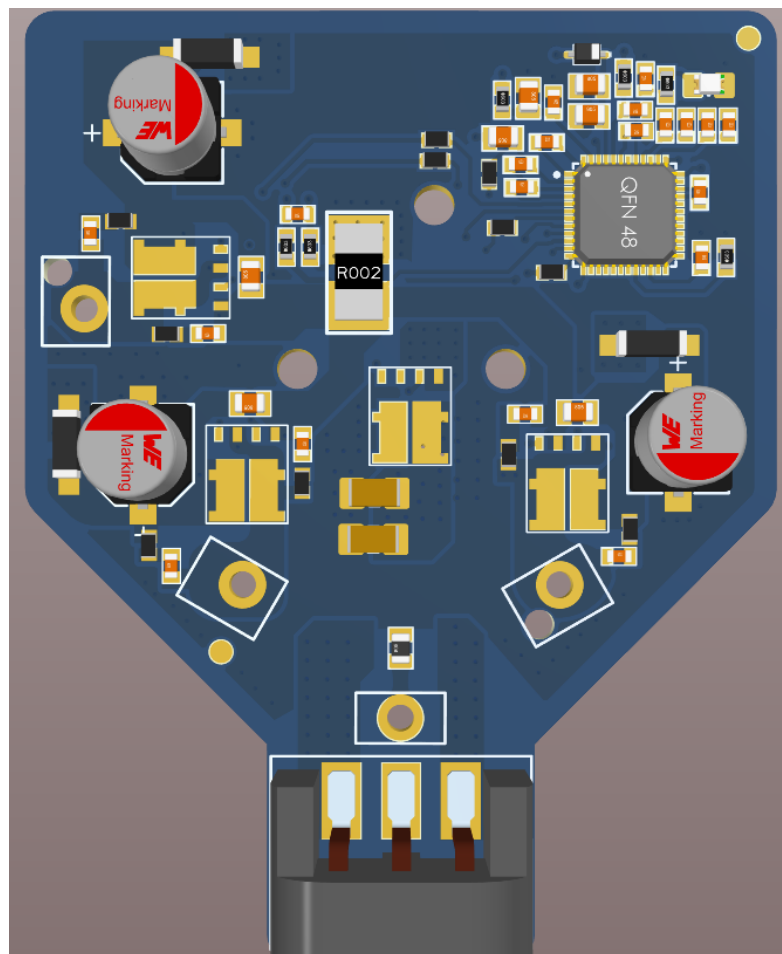

Jan Žagar

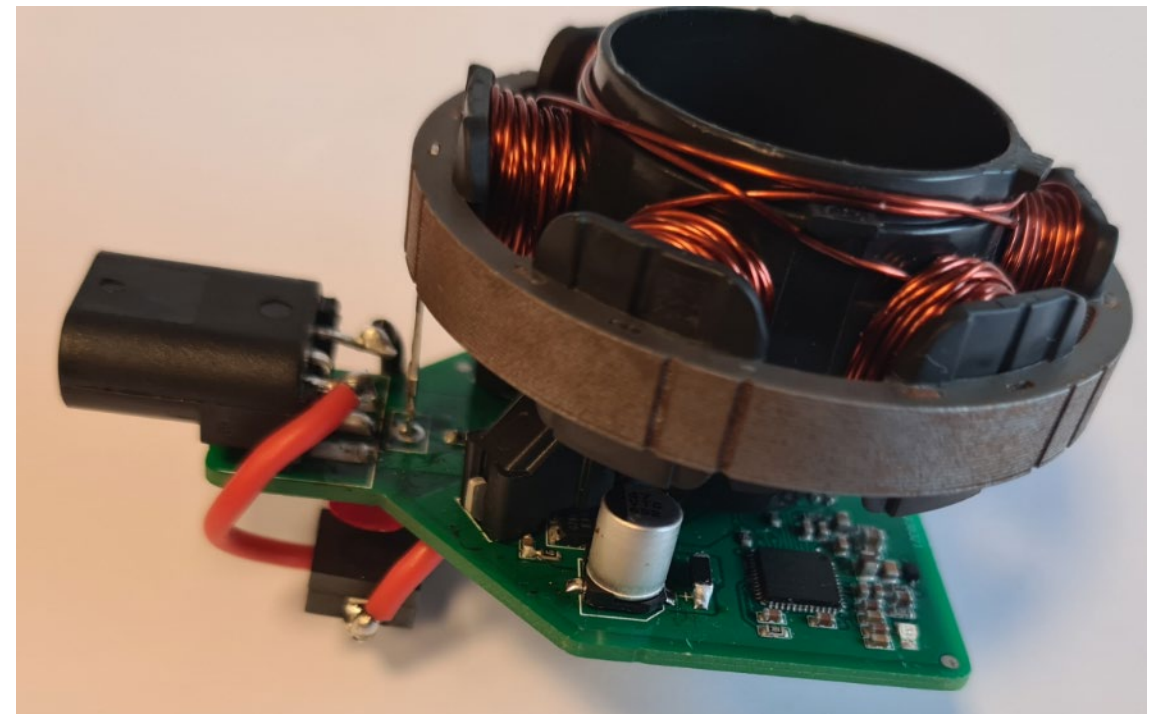
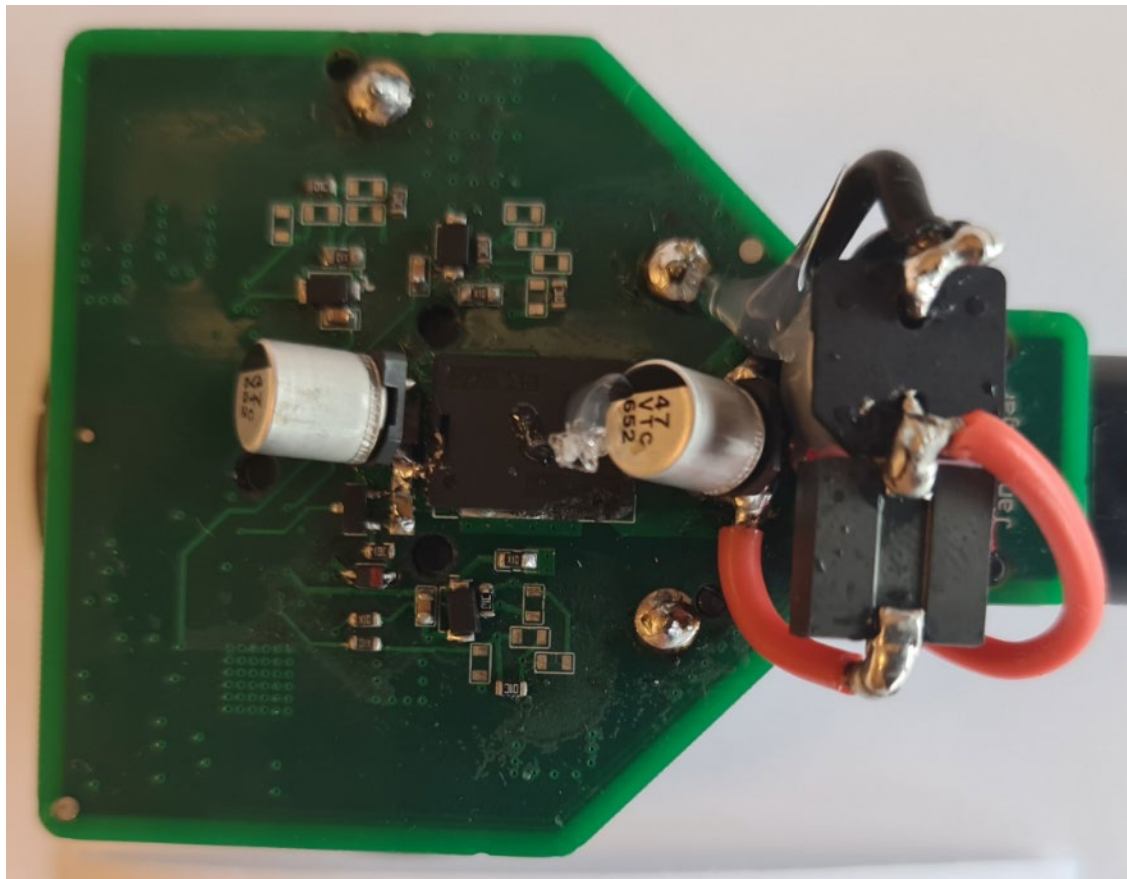

Jan Žagar- BOM

No.	Query	Qty	Matches	Part	Part Description	Distributor/SKU	Unit Price	Line Total	Batch Total	Notes
1	667-EEE-TK1V221	1	☑	Panasonic EEE-TK1V221UP	Aluminum Electrolytic Capacitor, 220 uF, 35 V, ± 20%, 3000 hours @ 125°C, Radial	Future Electronics 5059270 Stock: 0 Tape & Reel	0,4267	0,4267	426,6763	
2	710-744306025	1	☑	Würth Elektronik 744306025	Inductor, Power, 0.25uH, 20%, 10.6x10.4; Product Range: Würth Elektronik - We-hcm	RS 8008338 Stock: 0	0,603€ 1,1707	1,1707	1.170.6668	
3	667-EEE-TC1V470	4	☑	Panasonic EEETC1V470XP	Aluminum Electrolytic Capacitor, 47 uF, 35 V, ± 20%, 2000 hours @ 125°C, Radial	TTI EEE-TC1V470XP Stock: 2.700 Tape & Reel	0,2026	0,8102	810,2160	
4	80-C1206C475M5F	3	☑	KEMET C1206C475M5RACAUTO	Ceramic Capacitor, Multilayer, Ceramic, 50V, 20% +Tol, 20% -Tol, X7R, 15% TC, 4.7uF,	Mouser 80-C1206C475M5RACAUTO Stock: 75.276 Tape & Reel	0,1610	0,4830	483,0000	
5	81-BNX024H01L	1	☑	Murata BNX024H01L	EMI Filter Block 15A 50VDC Flat Style SMD Automotive Embossed T/R	LCSC C124739 Stock: 629	1,7457	1,7457	1.745.7000	
6	80-C1206C104KAF	1	☑	KEMET C1206C104KARECAUTO	Multilayer Ceramic Capacitor, 0.1 uF, 250 V, ± 10%, X7R, 1206 [3216 Metric]	TME C1206C104KARECAUTO Stock: 0	0,0406	0,0406	40,6000	
7	78-SQJ912BEP-T1	1	☑	Vishay SQJ912BEP-T1_GE3	VISHAY - SQJ912BEP-T1_GE3 - Dual MOSFET, Dual N Channel, 30 A, 40 V, 0.009	Verical SQJ912BEP-T1_GE3 Stock: 1.648	0,5202	0,5202	520,1699	
8	757-2SC3326-ALF	1	☑	Toshiba 2SC3326-ALF	Trans GP BJT NPN 20V 0.3A 150mW 3-Pin S-Mini T/R	Arrow Electronics 2SC3326-ALF Stock: 1	0,0398	0,0398	39,7606	
9	755-RB560VM-40F	1	☑	ROHM RB560VM-40FHTE-17	Schottky Diode, 40V, 0.5A, Sod-323FI Rohs Compliant: Yes [Rohm RB560VM-	TME RB560VM-40FHTE-17 Stock: 0	0,0397	0,0397	39,7000	
10	726-BAS3010B-03	1	☑	Infineon BAS3010B03WE6327HTSA1	Rectifier Diode, Schottky, 1 Phase, 1 Element, 1A, 30V V(RRM), Silicon	Rochester Electronics BAS3010B03WE6327HTSA1 Stock: 90.000	0,0896	0,0896	89,6489	
11	710-782963600	3	☑	Würth Elektronik 782963600	Ferrite Bead, 60 Ohm, 6A, 1806 Rohs Compliant: Yes [Würth Elektronik 782963600	Farnell 3551399 Stock: 1.785	0,1450	0,4350	435,0000	
12	78-SQJ980AEP-T1	3	☑	Vishay SQJ980AEP-T1_GE3	Dual Mosfet, Dual N Channel, 17 A, 75 V, 0.041 Ohm, 10 V, 2 V	Farnell 2400407 Stock: 0	0,3400	1,0200	1.020.0000	
13	833-SM4004PL-TP	3	☑	MCC SM4004PL-TP	Rectifier Diode, 1 Phase, 1 Element, 1A, 400V V(RRM), Silicon	LCSC C151800 Stock: 2.160	0,0196	0,0588	58,8000	
14	581-08055C104K	8	☑	AVX 08055C104KAT2A	Multilayer Ceramic Capacitor, 0.1 uF, 50 V, ± 10%, X7R, 0805 [2012 Metric]	Rutronik KKK6687 Stock: 452.000	0,0056	0,0449	44,8800	

Tekmovalec



cena tranzistorjev



Cena kondenzatorjev



Cena dušilk



Cena diod



Skupaj



Jan Žagar

1,58 €

1,81 €

2,78 €

0,19 €

6,36 €

Tekmovalec



kvalifikacija



temp. območje



ostale zahteve



Cena komponent

Točke



Jan Žagar

3

3

3

6,36 €

-22,8

Jan Žagar - delovanje

- Izkoristek 85,05%
- Prenihaj 1,2V
- Padec napetosti 0,163 V
- Tok nasprotne polaritete 13,2 mA

Tekmovalec	Osnovna	Izkoristek	Polariteta	Padec r	Prenihaj	Točke
Jan Žagar	12	10	0	5	5	32

Jan Žagar - CE

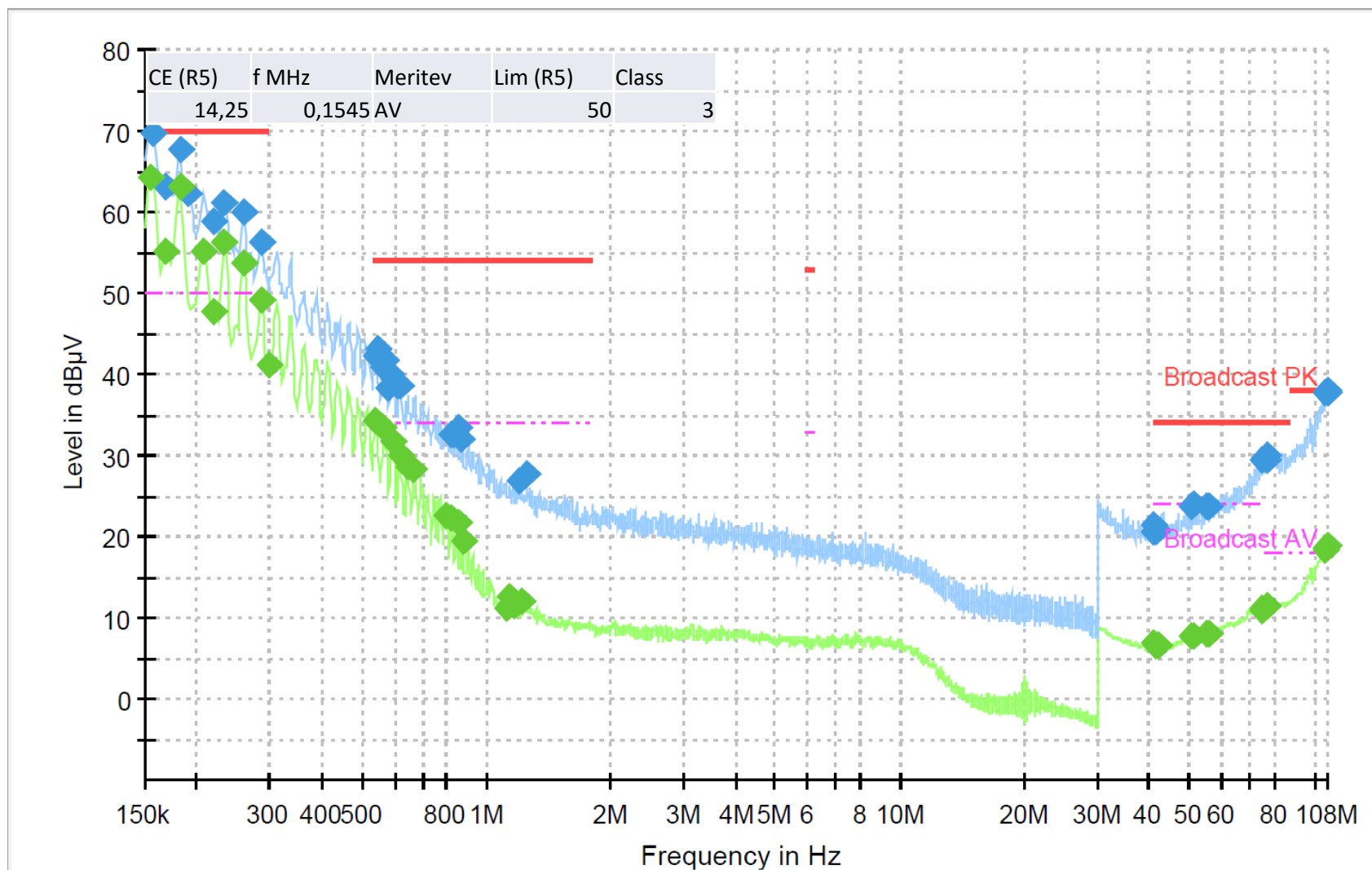

Jan Žagar - VW

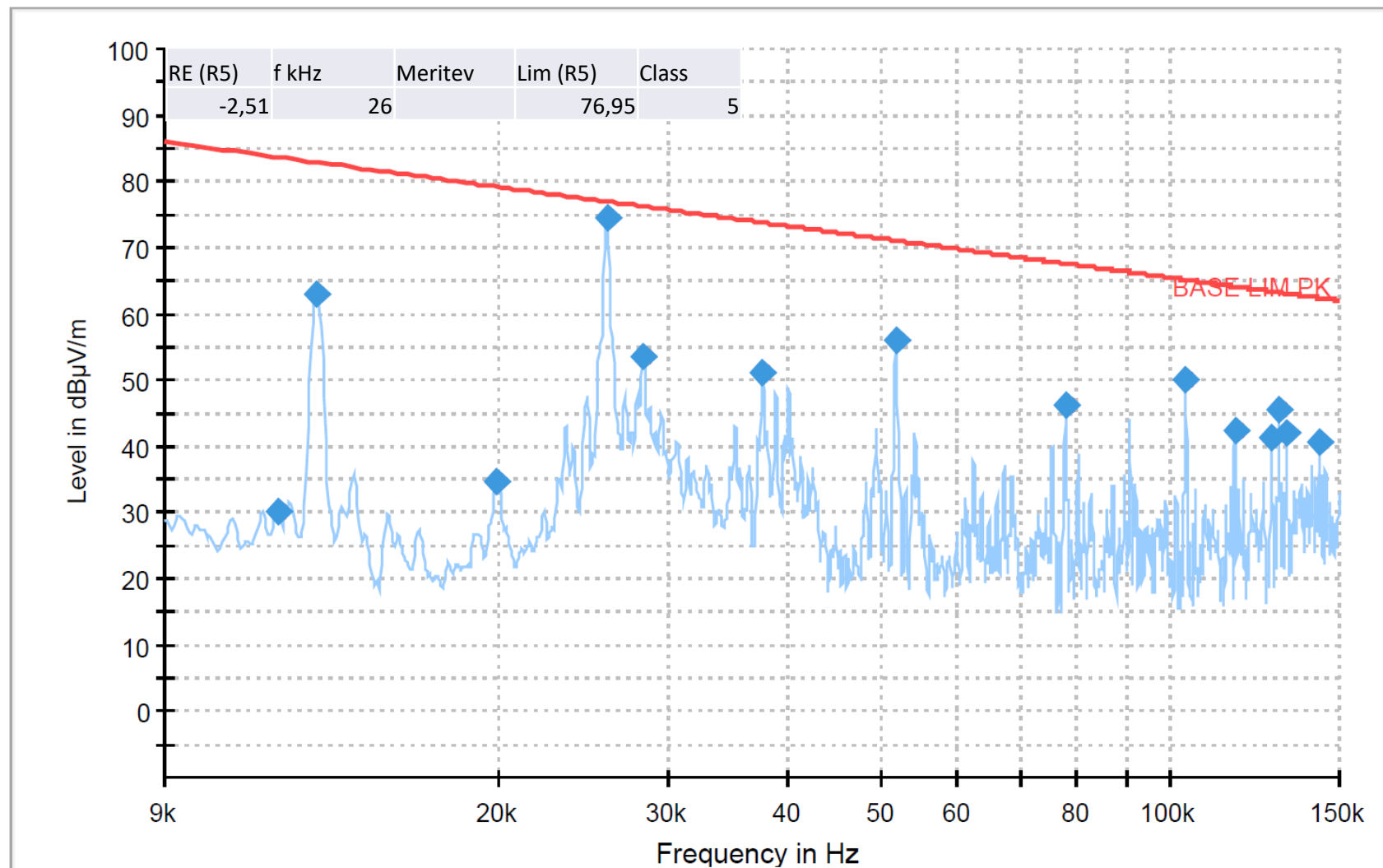

Jan Žagar - RE

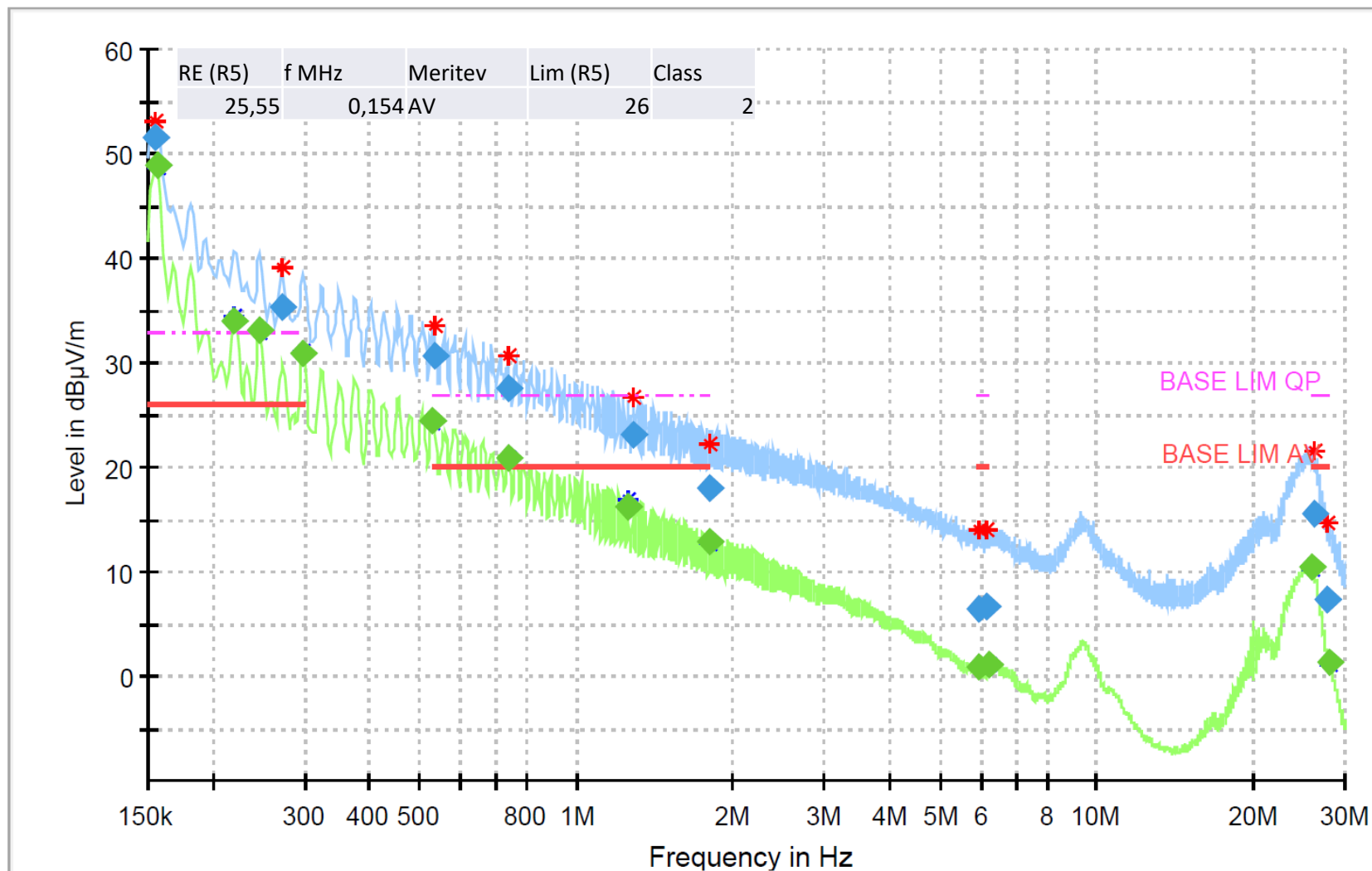

Jan Žagar - RE

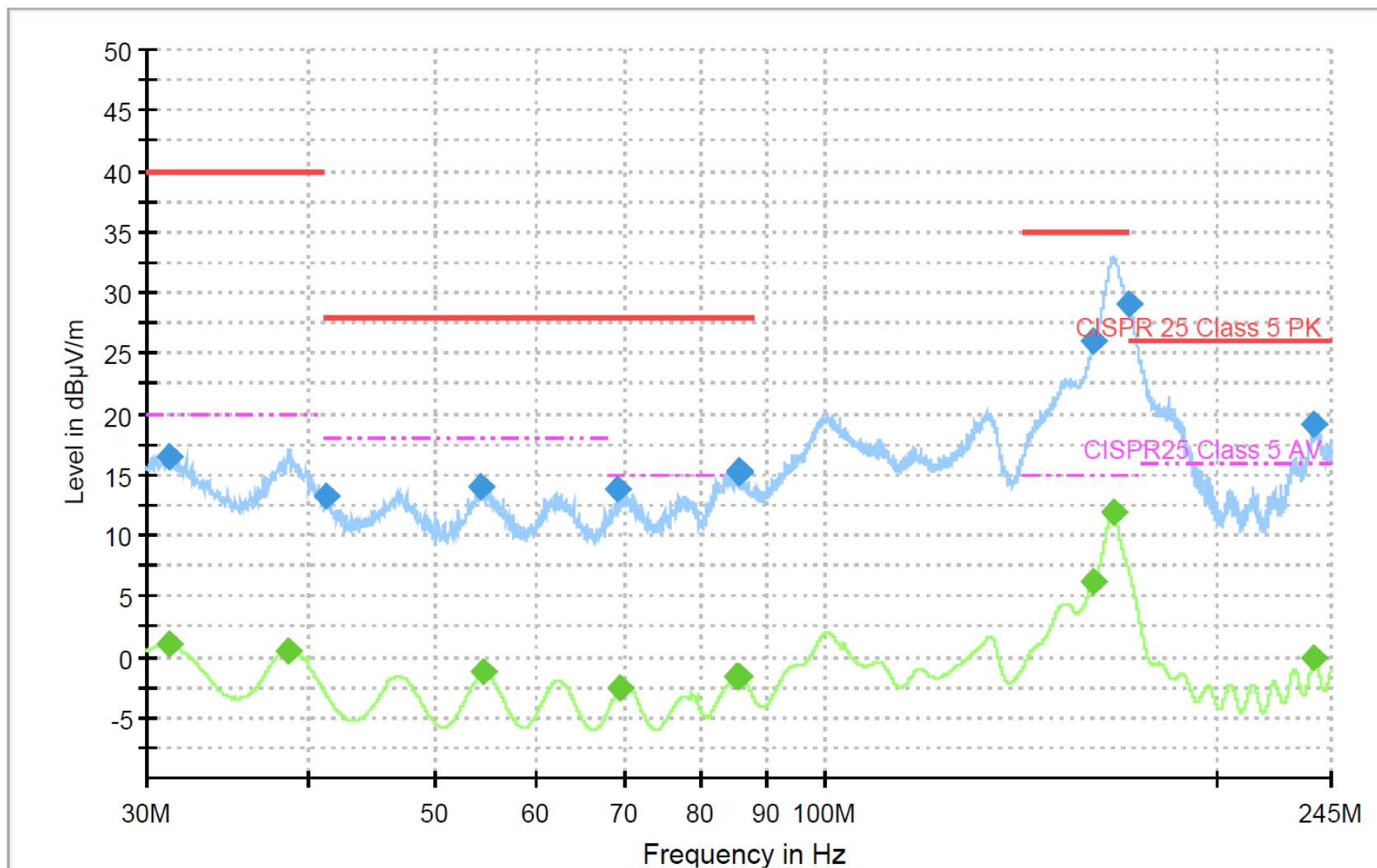

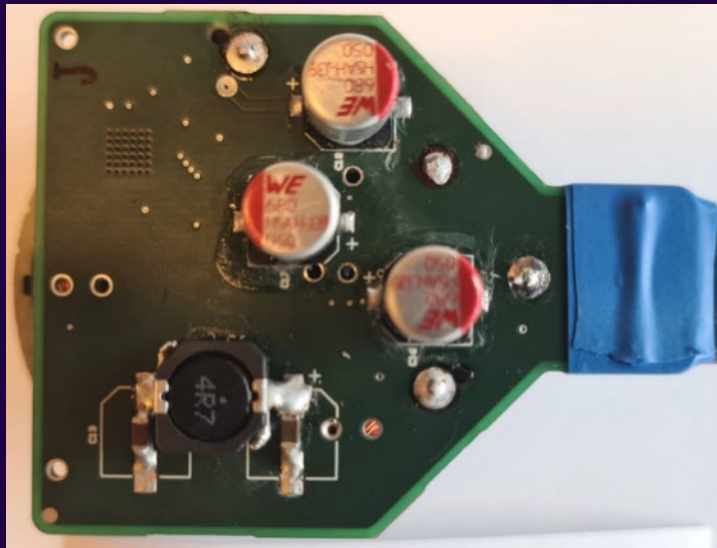

KOLEKTOR



Predstavitev

Jaša Vid Meh Peer

Shema

- Zaščita pred napačno polariteto
- Pi filter
- DC-link
- Dual MOSFETi



Dual MOSFETs (3,127)

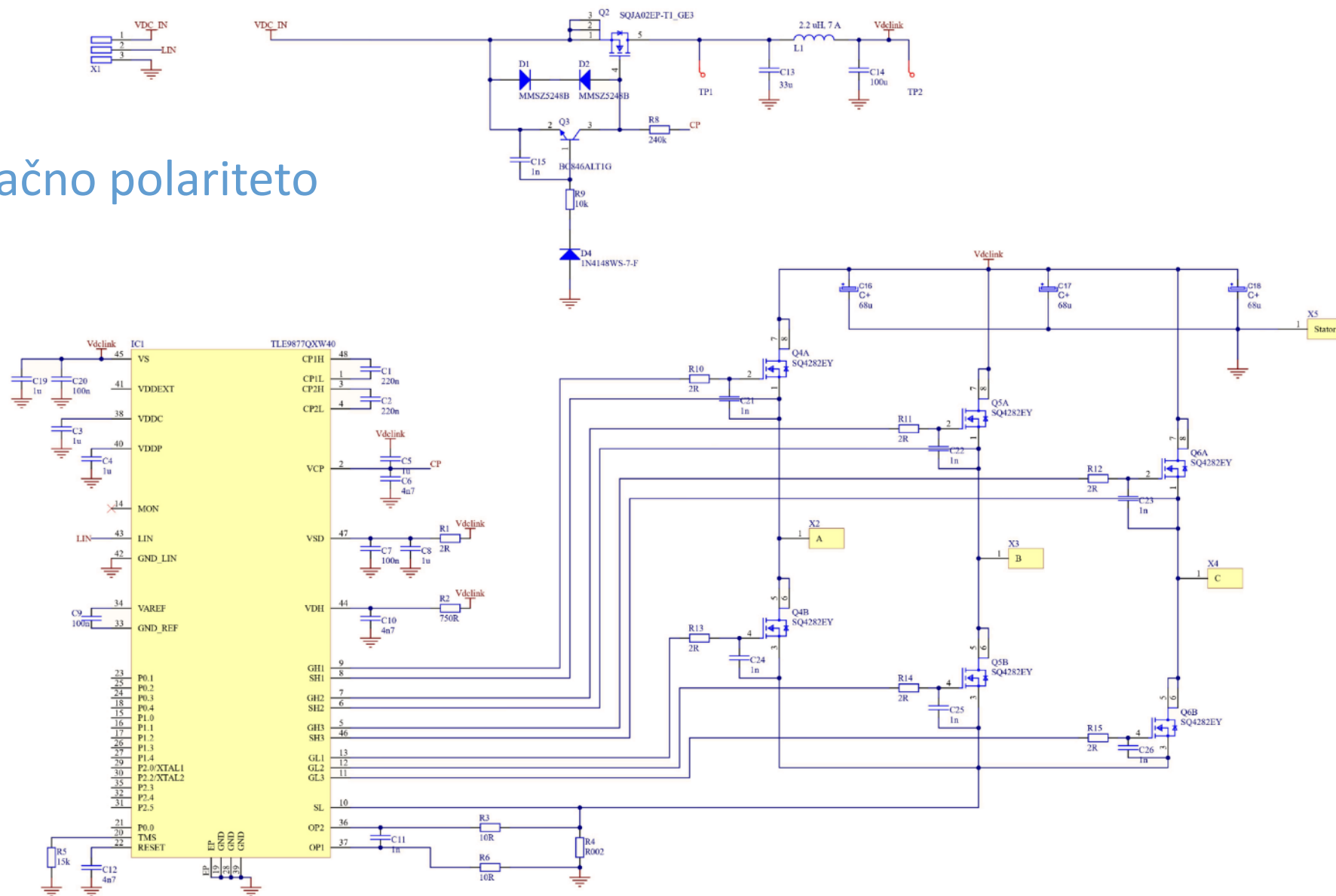

Reverse-Polarity protection in filter

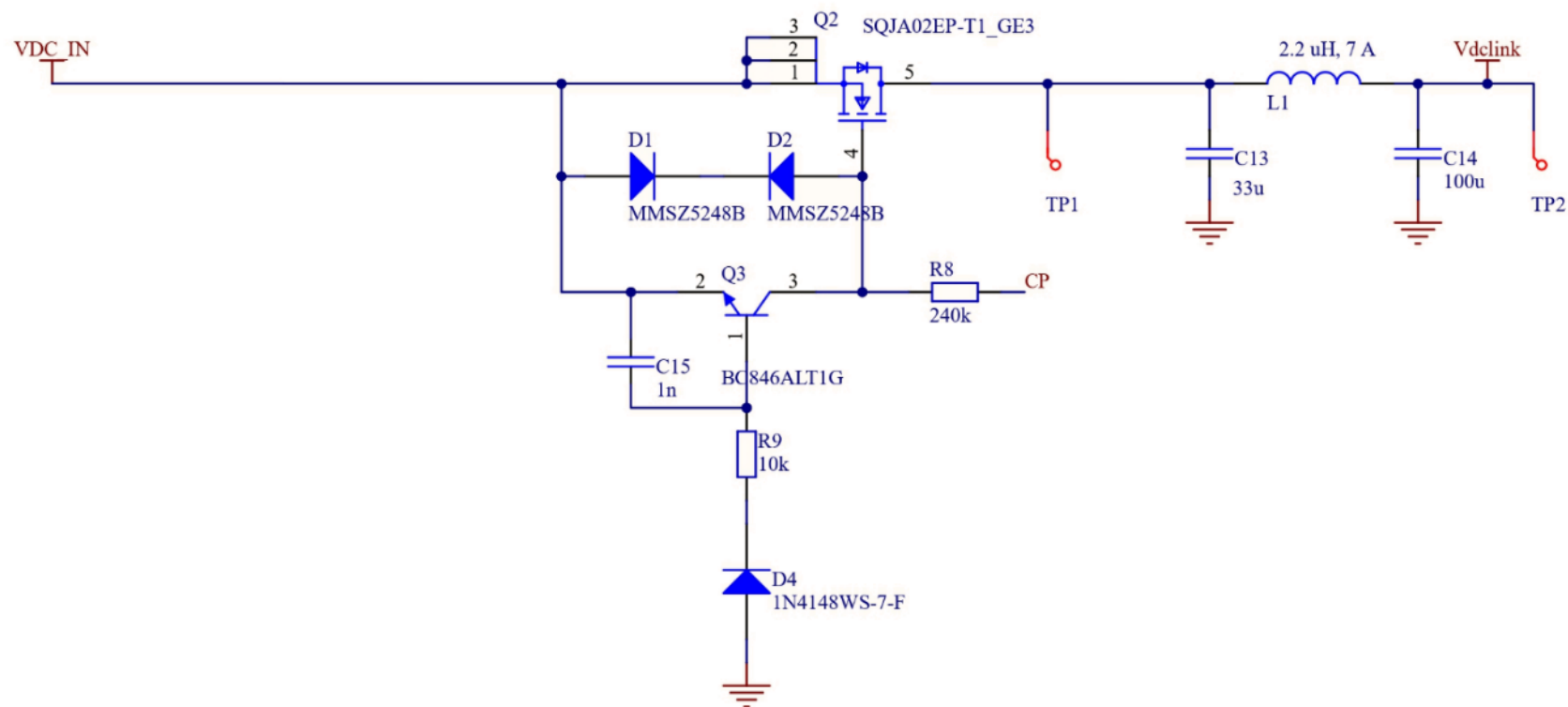

Komponente

Dual N-Channel 30 V MOSFETi

- VISHAY SQ4282EY-T1_GE3
- $V_{ds_max} = 30\text{ V}$
- $R_{ds_on} = 10\text{ m}\Omega$
- $I_D = 8\text{ A}$



Polymer aluminum kondenzatorji

- Wurth Hybrid Alu. Ele. Capacitor
- $C = 68\text{ }\mu\text{F} \times 3$
- $ESR = 30\text{ m}\Omega / 3$
- $I_{ripple} = 1,25\text{ A} \times 3$



Načrt tiskanega vezja

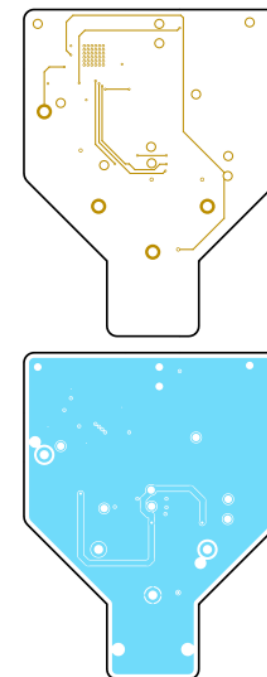
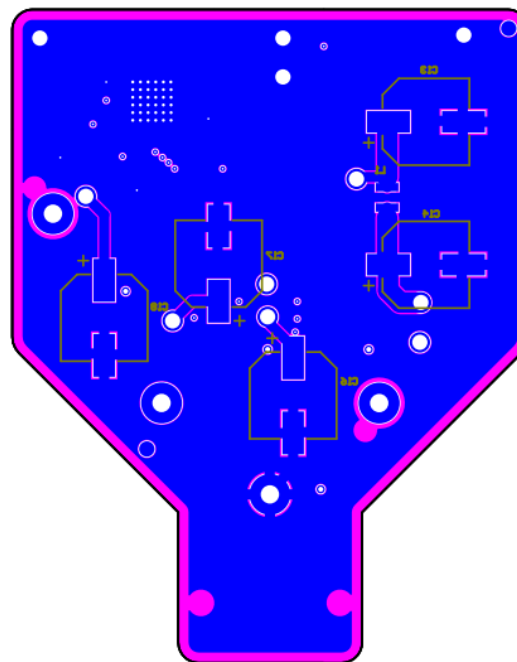
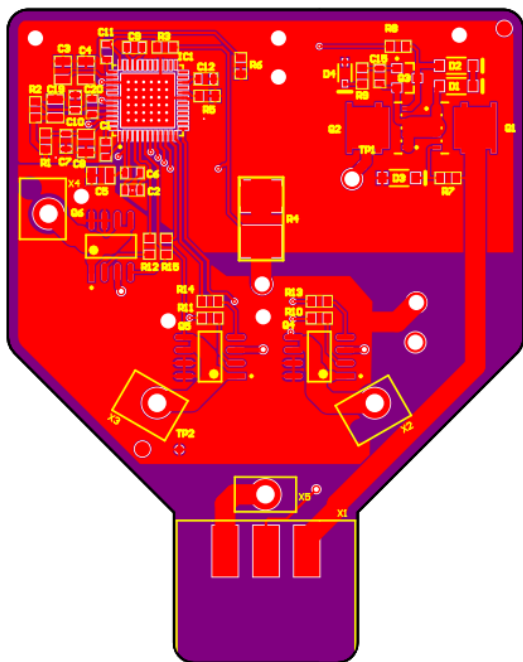

Načrt tiskanega vezja

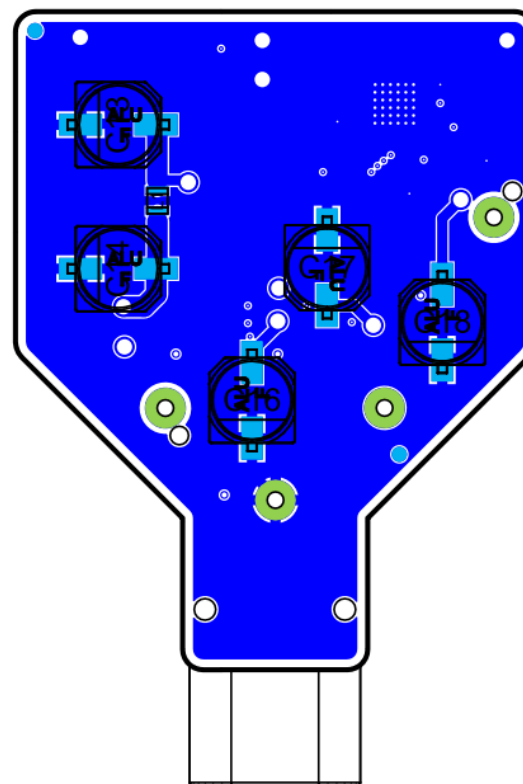
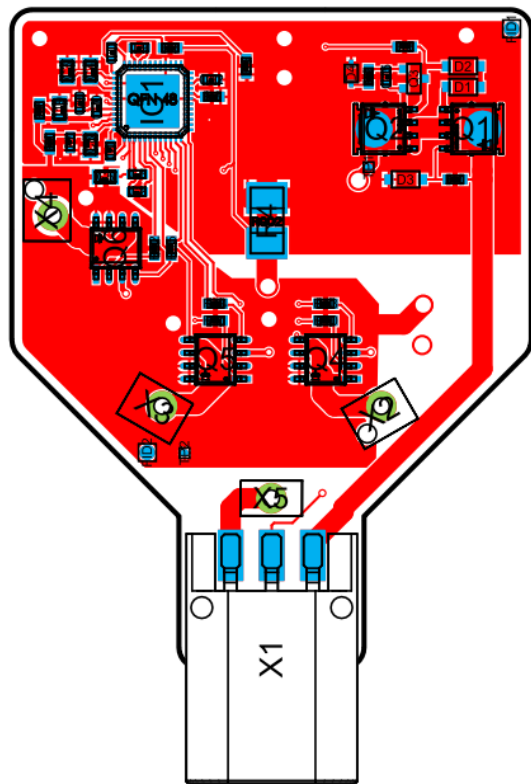

Načrt tiskanega vezja

- Kratke tokovne zanke

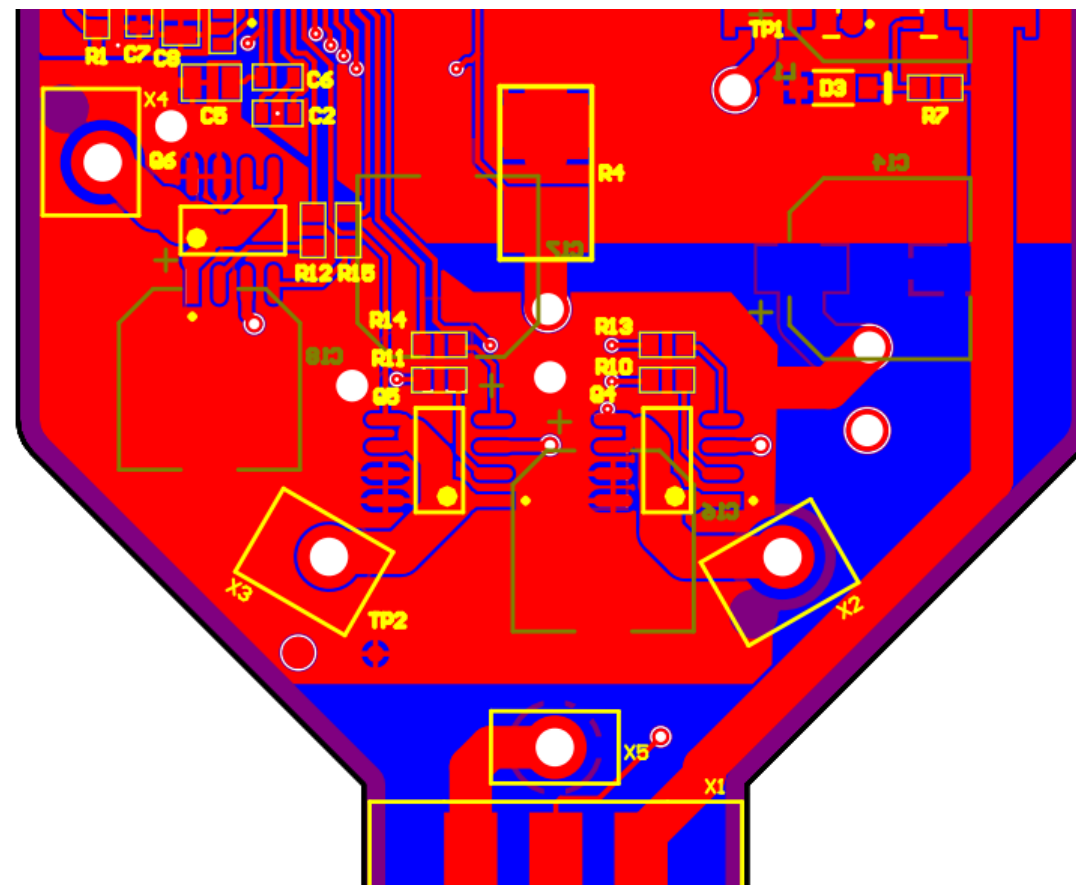

Popravljanje napak

- Vhodna tuljava
- Current sensing
- Miller-jeva kapacitivnost

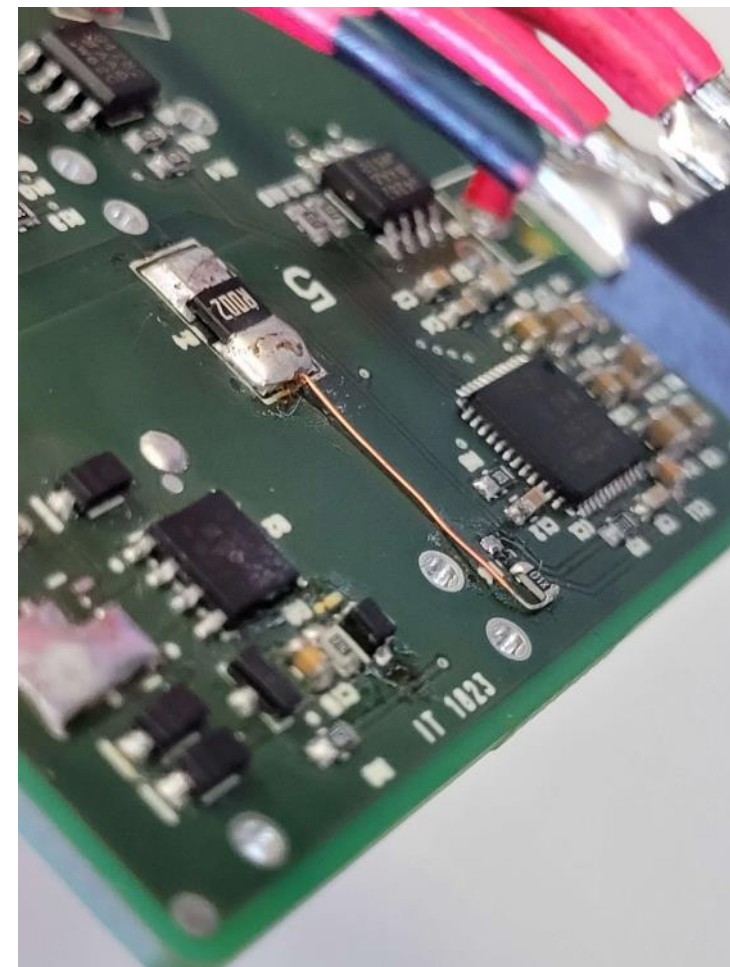
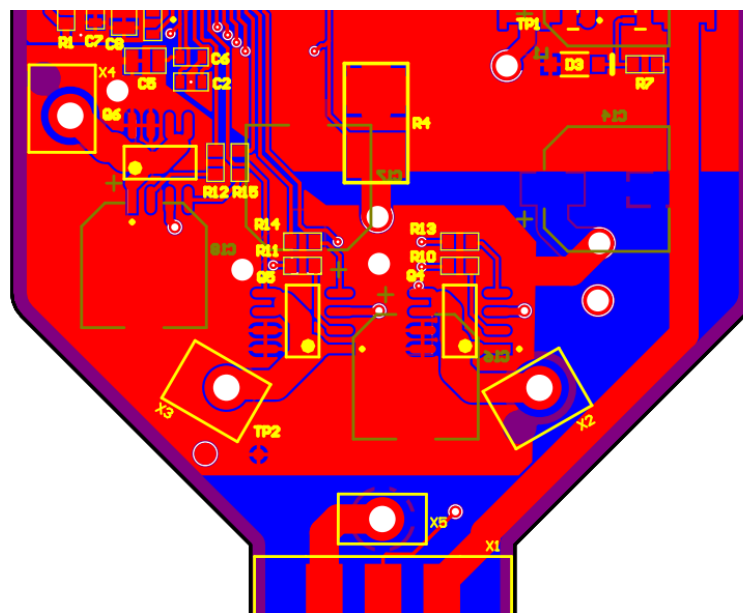

Popravljanje napak

- Vhodna tuljava
- Current sensing
- Miller-jeva kapacitivnost

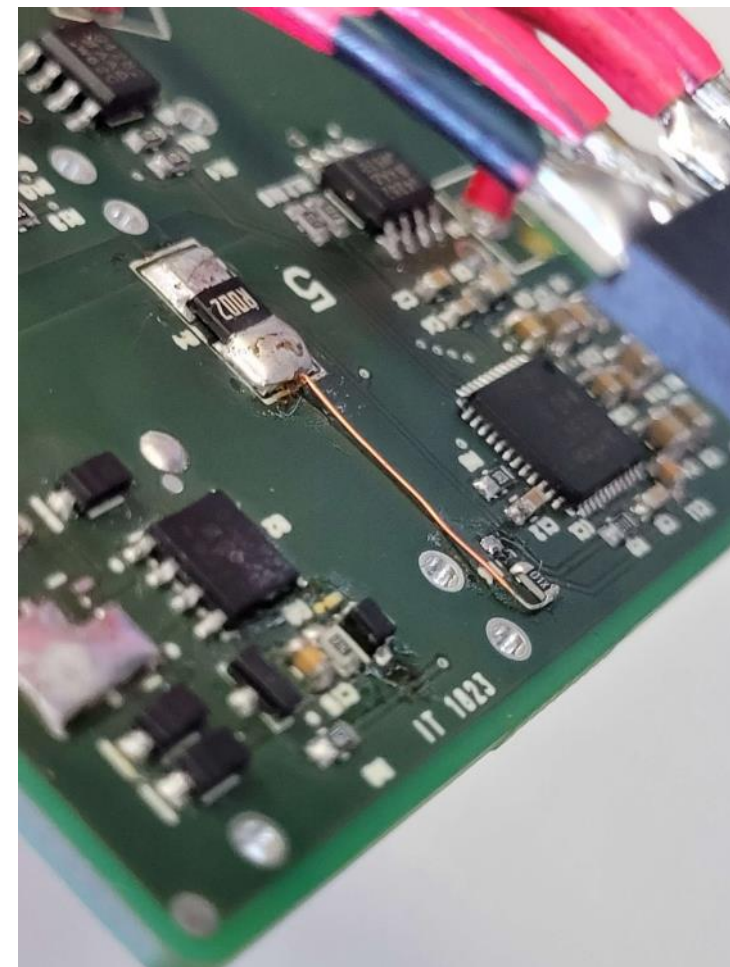
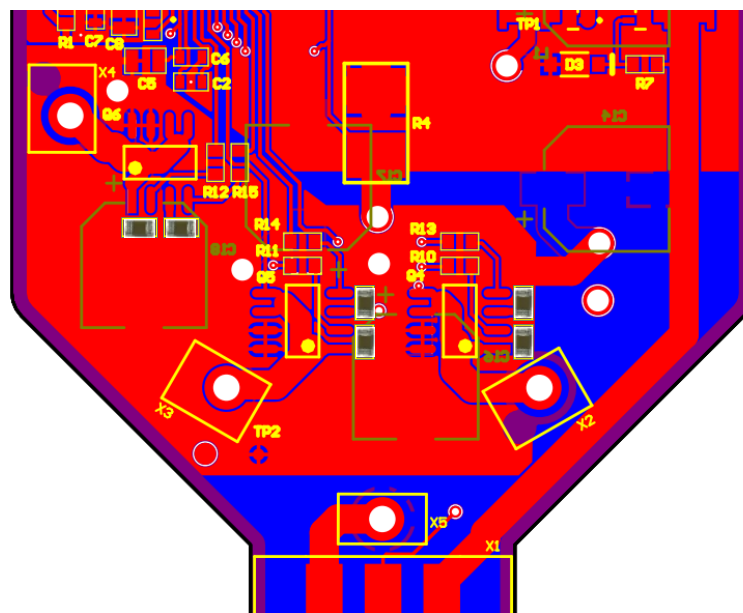

Preliminarne meritve

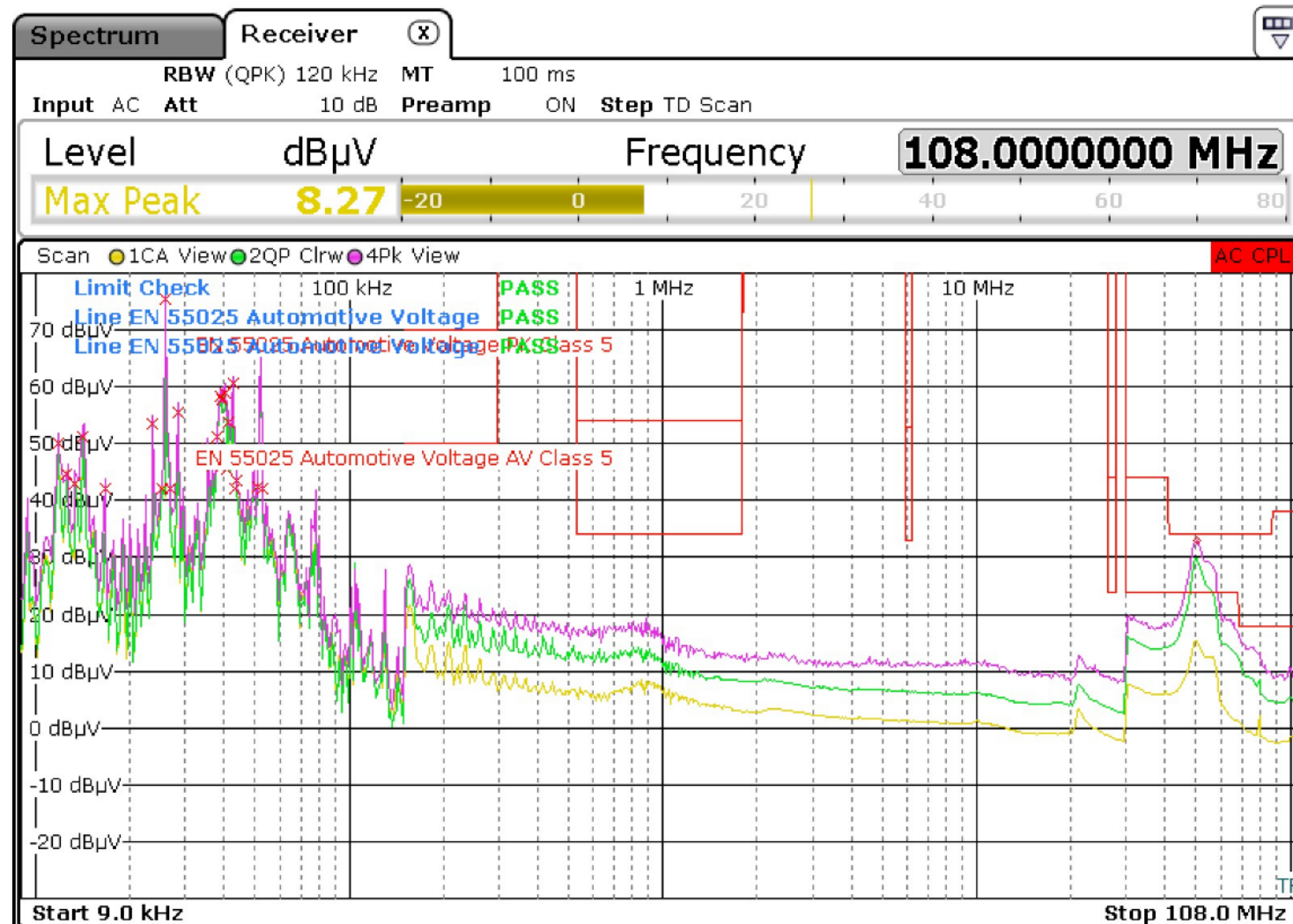
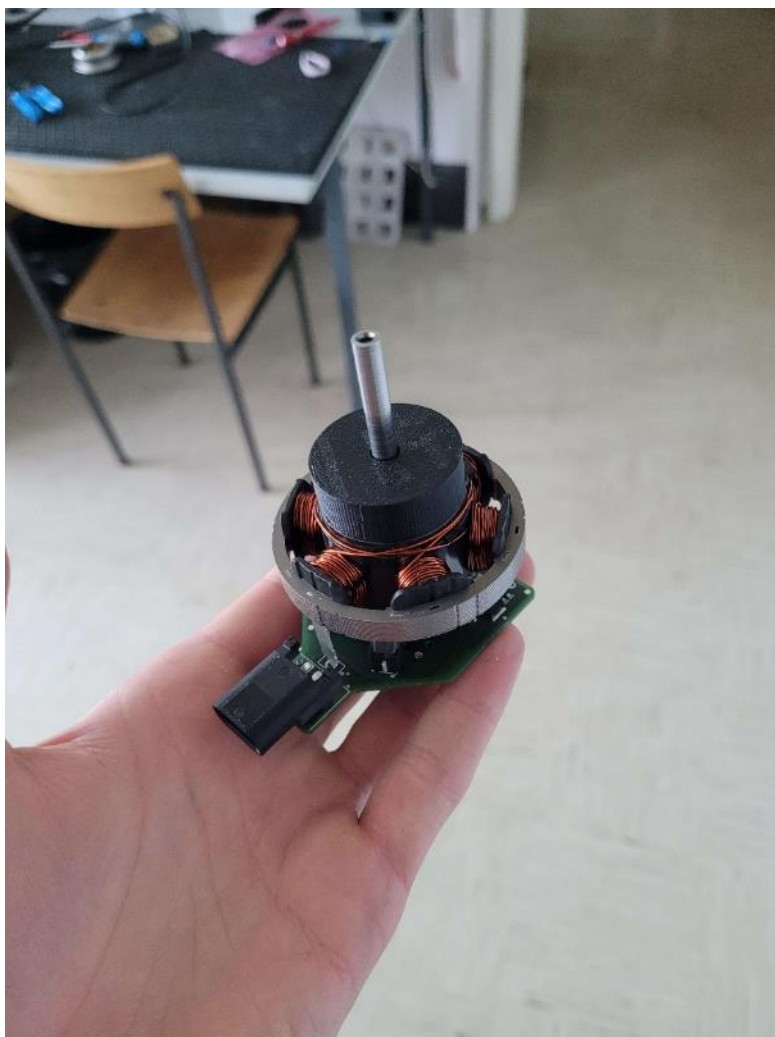

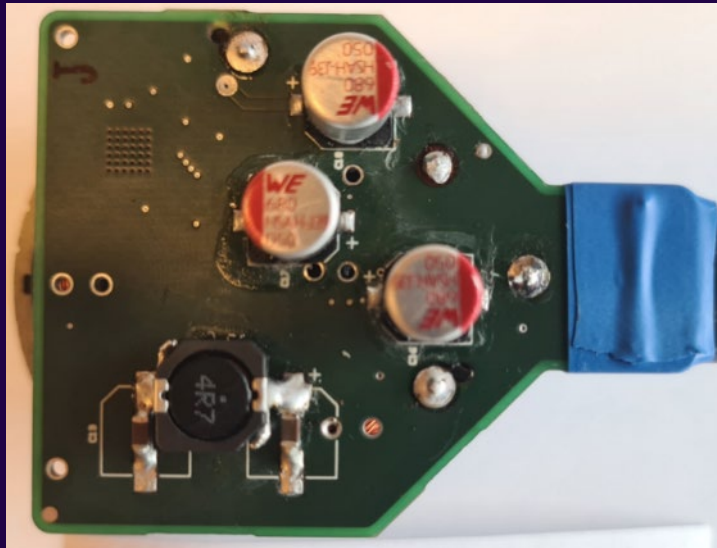

KOLEKTOR



Rezultati

Jaša Vid Meh Peer

Jaša Vid Meh Peer

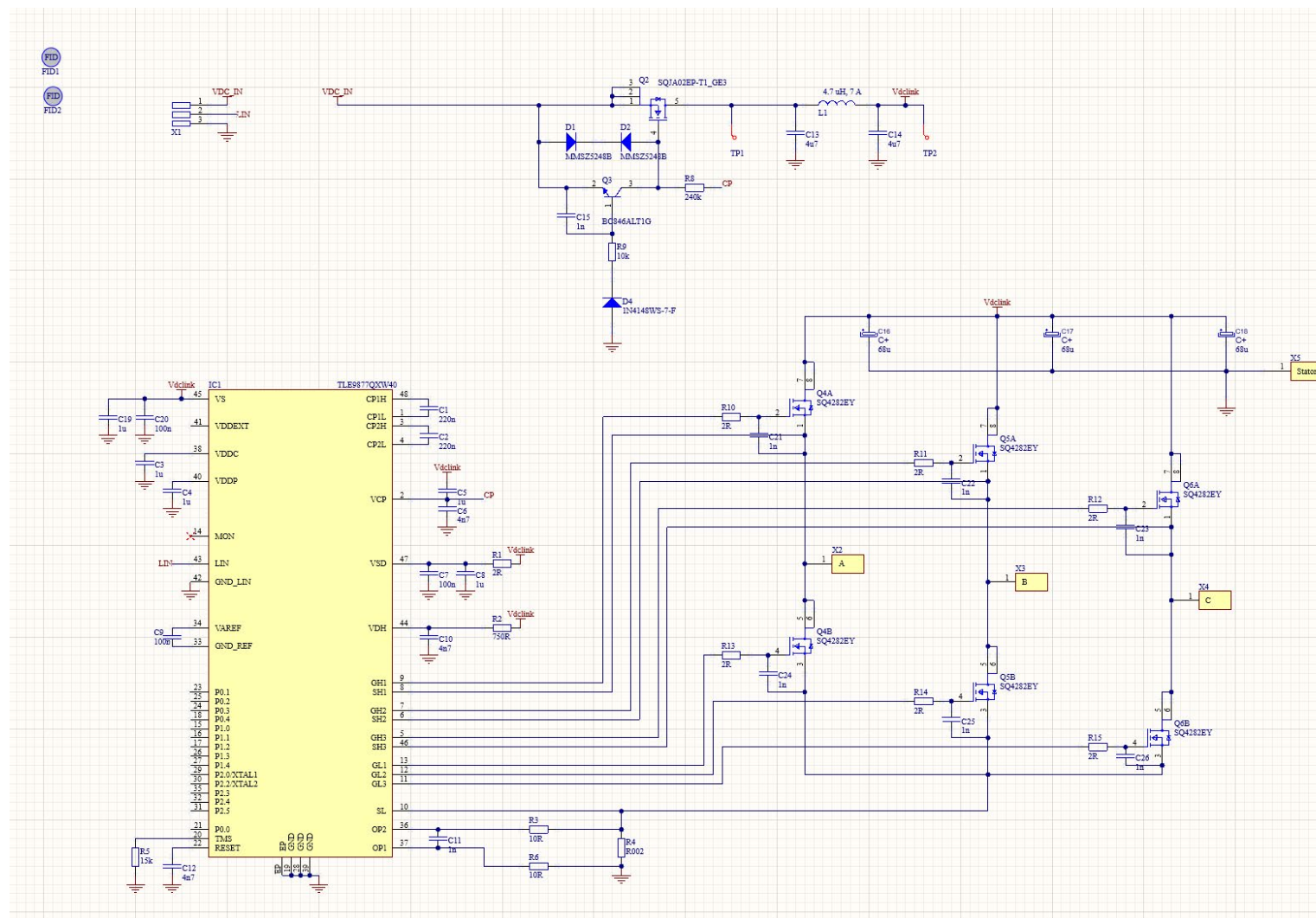

Jaša Vid Meh Peer

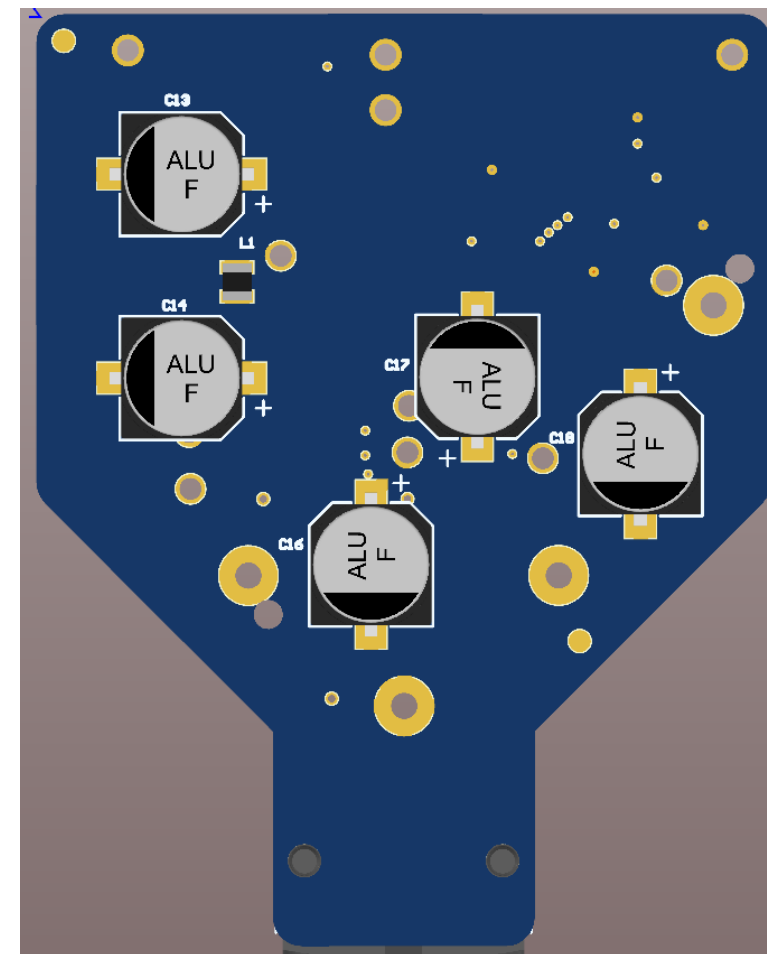
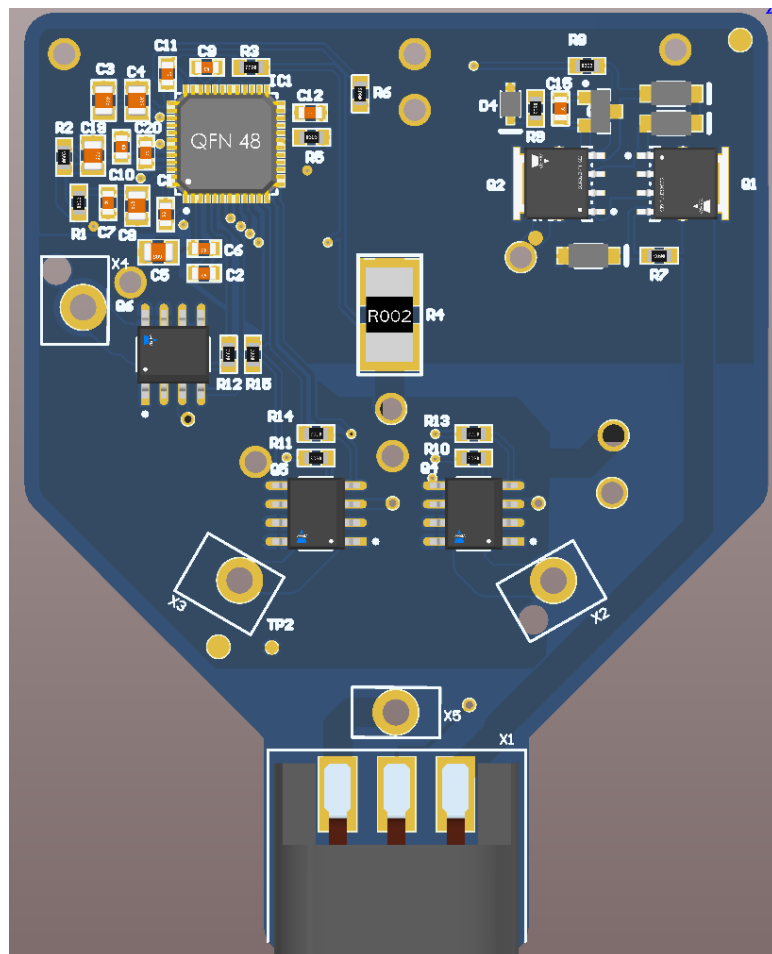

Jaša Vid Meh Peer

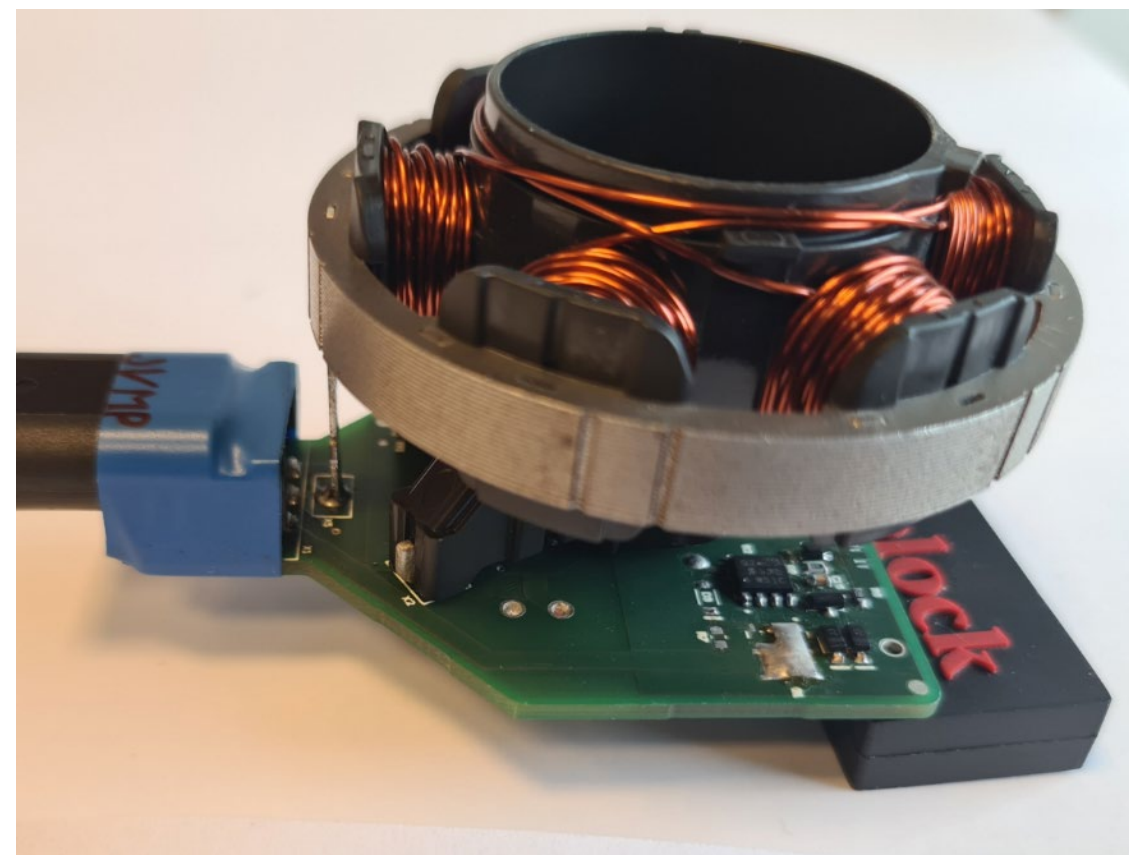
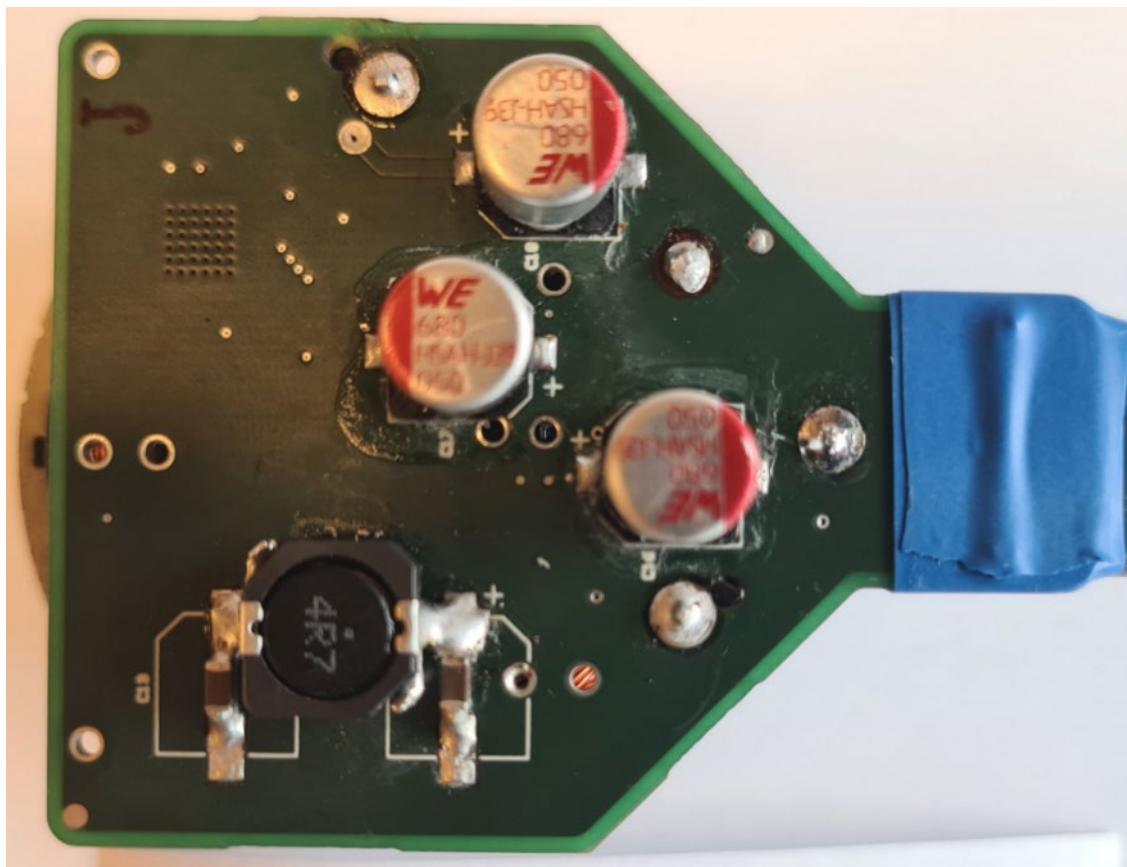

Jaša Vid Meh Peer - BOM

No.	Query	Qty	Matches	Part	Part Description	Distributor/SKU	Unit Price	Line Total	Batch Total	Notes
1	78-SQ4282EY-T1_	3		Vishay SQ4282EY-T1_GE3	Dual N-Channel 30 V 12.3 mOhm 3.9 W SMT Automotive Power Mosfet - SOIC-8	Mouser 78-SQ4282EY-T1_GE3 Stock: 14.321 Tape & Reel	0,5310	1,5930	1.593,0000	
2	SQJA02EP-T1_GE	1		Vishay SQJA02EP-T1_GE3	Transistor MOSFET N-CH 60V 60A 8-Pin PowerPAK SO	Arrow Electronics SQJA02EP-T1_GE3 Stock: 3.000 Cut Tape	0,5407	0,5407	0,5407067	
3	1459036	1		onsemi BC846ALT1G	Trans General Purpose BJT NPN 65 Volt 0.1A 3-Pin SOT-23 Tape and Reel	Newark 58M4029 Stock: 156.439	0,0150	0,0150	0,150040	
4	710-88501220904:	2		Würth Elektronik 885012209048	Multilayer Ceramic Capacitor, Wcap-Csgp Series, 4.7 F, 10%, X7r, 50 V, 1210 [3225	Farnell 2468760 Stock: 0	0,271€ 0,3030	0,6060	606,0000	
5	732-87558575300:	3		Würth Elektronik 875585753005	Cap, 68Uf, 50V, Alu Elec, Hybrid, Smd Rohs Compliant: Yes Würth Elektronik	DigiKey 732-875585753005TR-ND Stock: 1.000 Tape & Reel	1,21€ 1,6118	4,8353	4.835,2800	
6	710-7447714047	1		Würth Elektronik 7447714047	Inductor Power Shielded Wirewound 4.7uH 30% 100KHz Ferrite 7A 12.4mOhm	Newark 88T7103 Stock: 1.072	0,579€ 0,8956	0,8956	0,895512	
7	MMSZ5248B	2		Diotec MMSZ5248B	Zener Diode, 18V V(Z), 5%, 0.5W, Silicon, Unidirectional	TME MMSZ5248B-DIO Stock: 2.054	0,0189	0,0378	37,8000	
8	1N4148WS-7-F	1		Diodes Inc. 1N4148WS-7-F	Rectifier Diode Small Signal Switching 75V 0.3A 4ns 2-Pin SOD-323 T/R	TME 1N4148WS-7-F Stock: 0	0,0199	0,0199	19,9000	

Tekmovalec cena tranzistorjev Cena kondenzatorjev Cena dušilk Cena diod Skupaj

Jaša Vid Meh Peer 2,15 € 4,17 € 0,58 € 0,06 € 6,96 €

Tekmovalec kvalifikacija temp. območje ostale zahteve Cena komponent Točke

Jaša Vid Meh Peer 3 3 3 6,96 € -25,8

Jaša Vid Meh Peer - delovanje

- Izkoristek 83,90%
- **Prenihaj 5,2V**
- Padec napetosti 0,130 V
- Tok nasprotne polaritete 1,32 mA

Tekmovalec	Osnovna	Izkoristek	Polariteta	Padec r	Prenihaj	Točke
Jaša Vid Meh Peer	12	8	5	5	0	30

Jaša Vid Meh Peer - CE

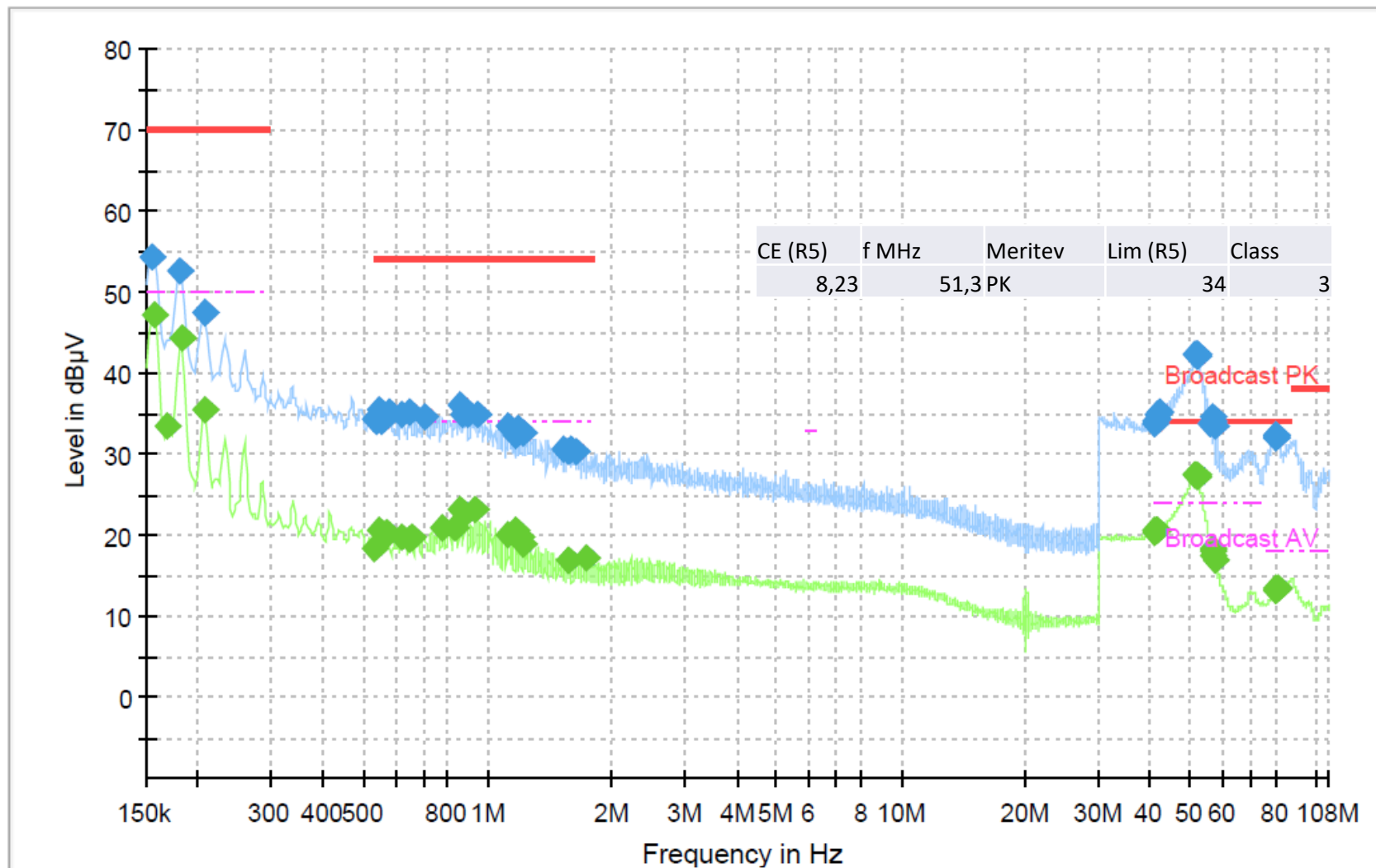

Jaša Vid Meh Peer - VW

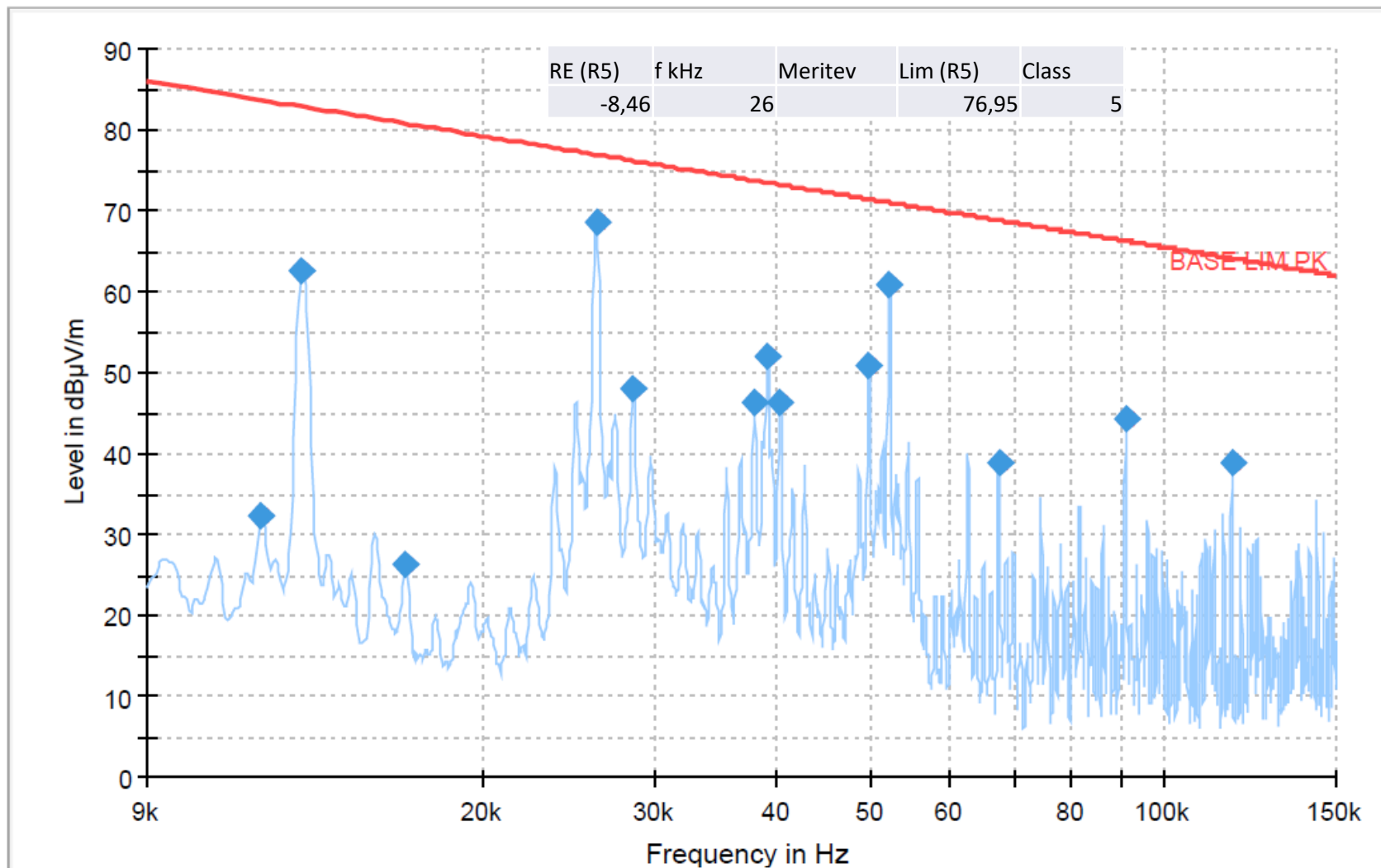

Jaša Vid Meh Peer - RE

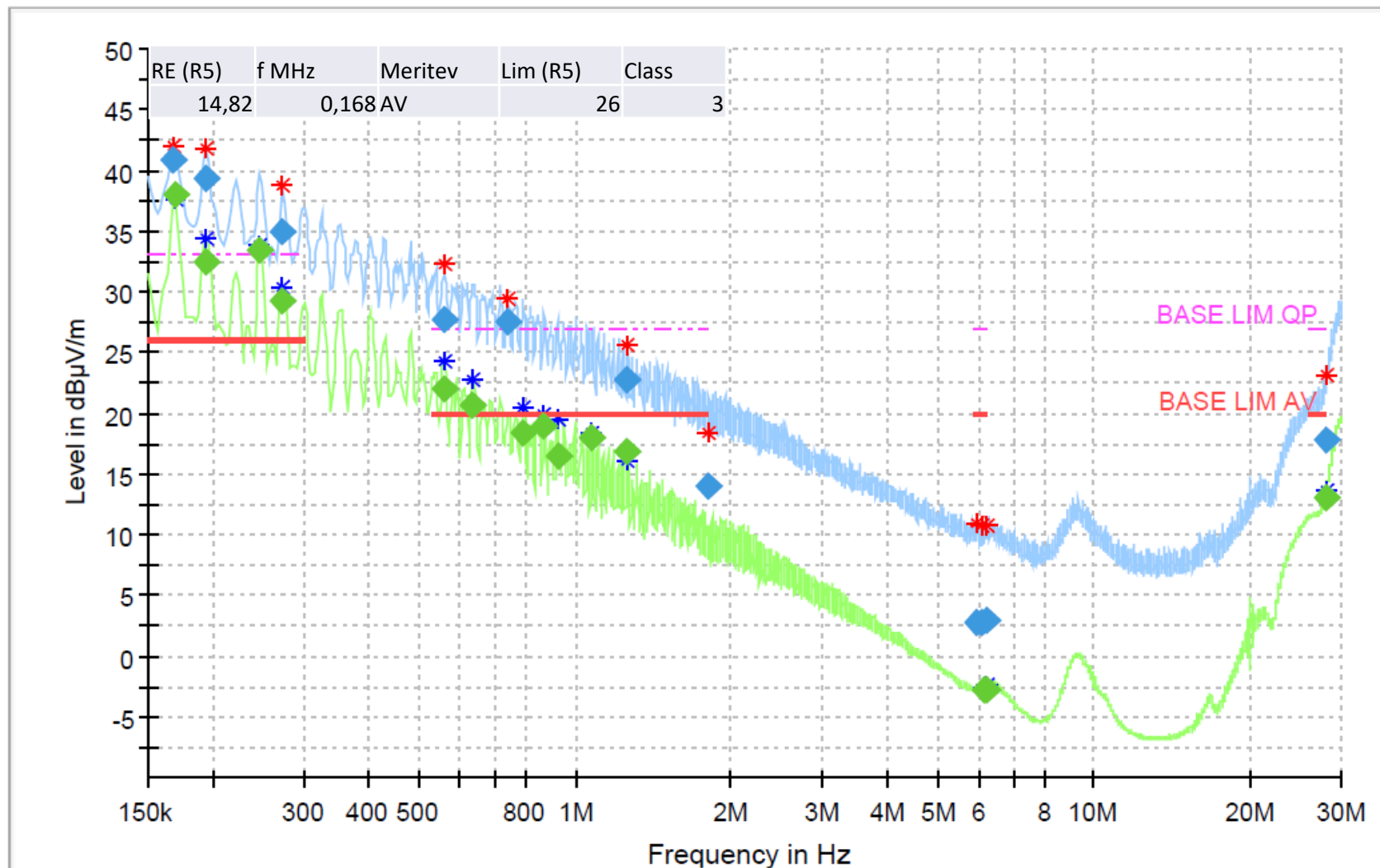

Jaša Vid Meh Peer

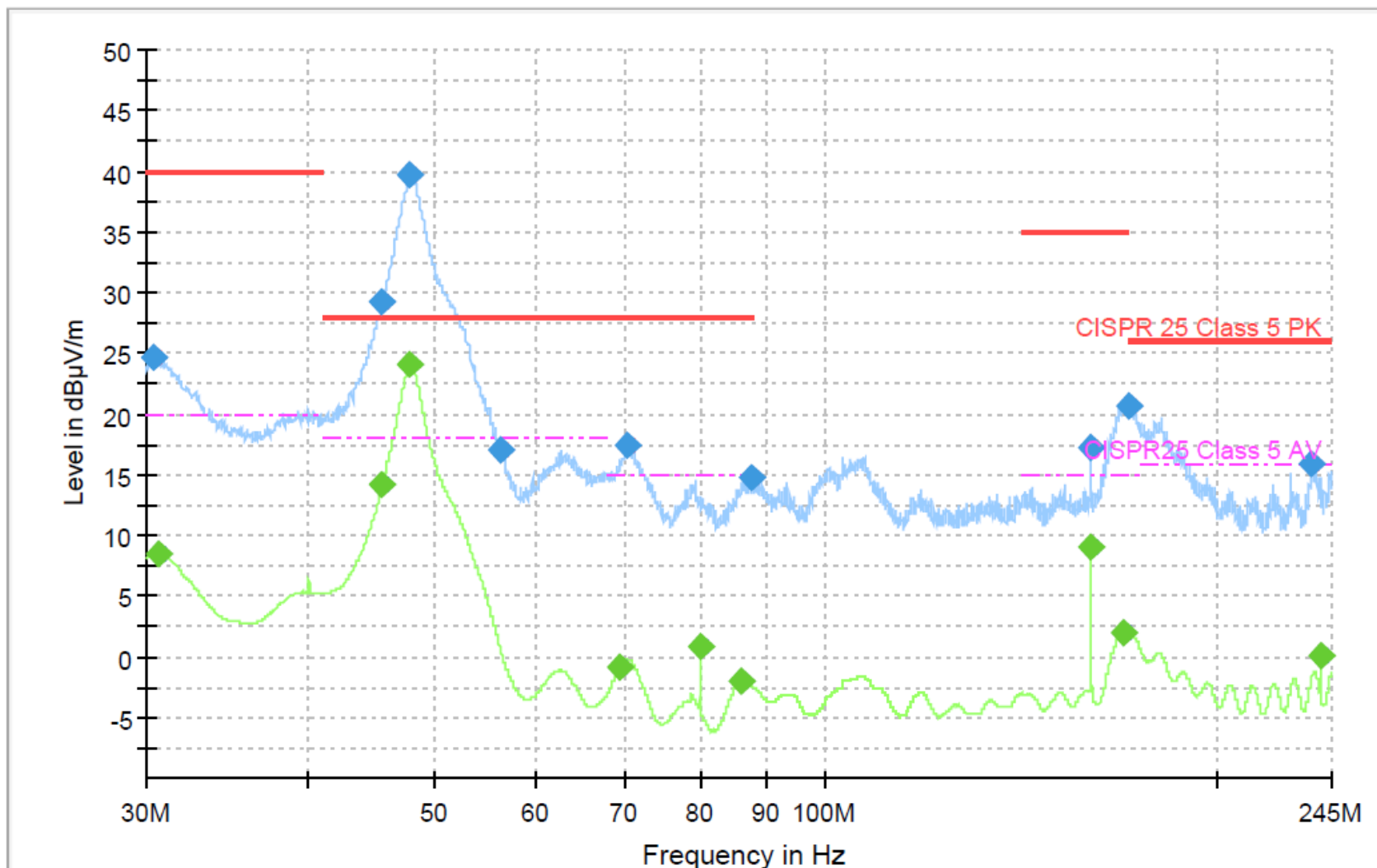

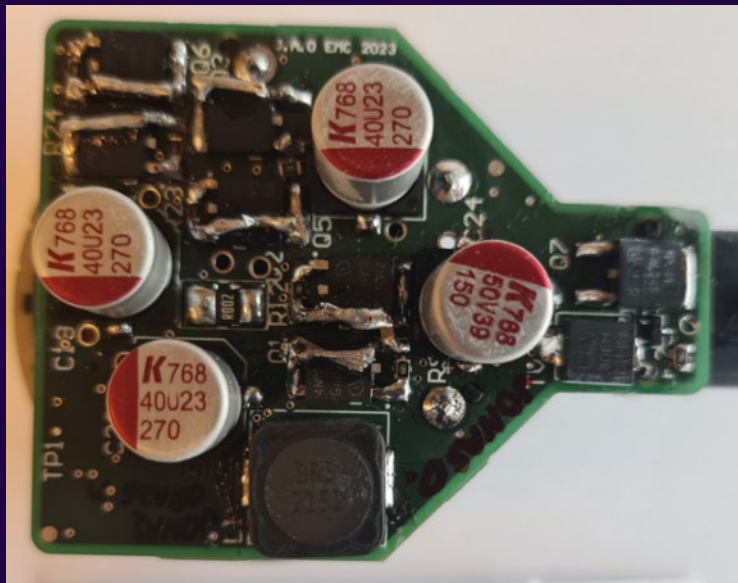

KOLEKTOR



Predstavitev

Jonas Oražem

Cilji izdelka

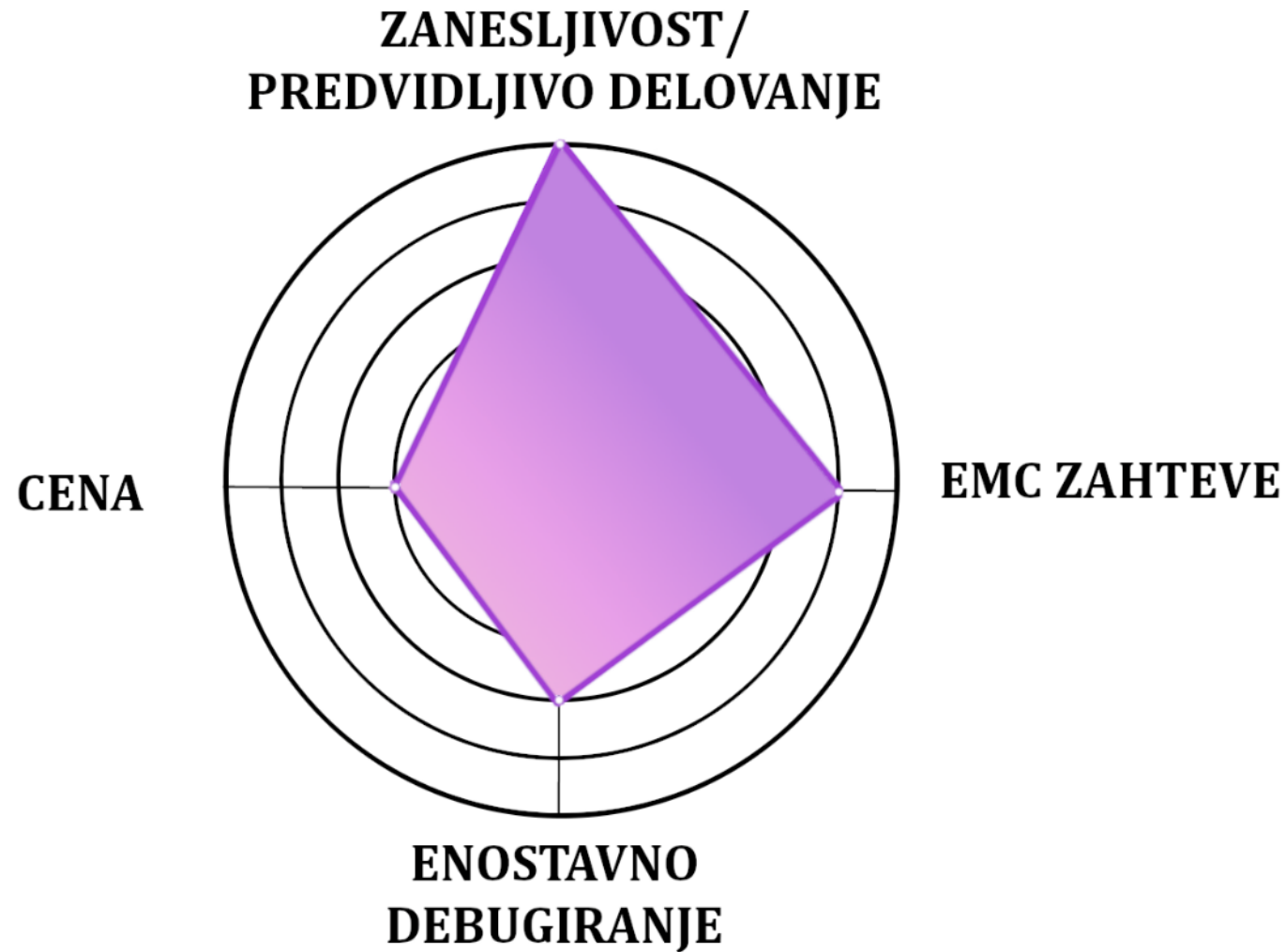

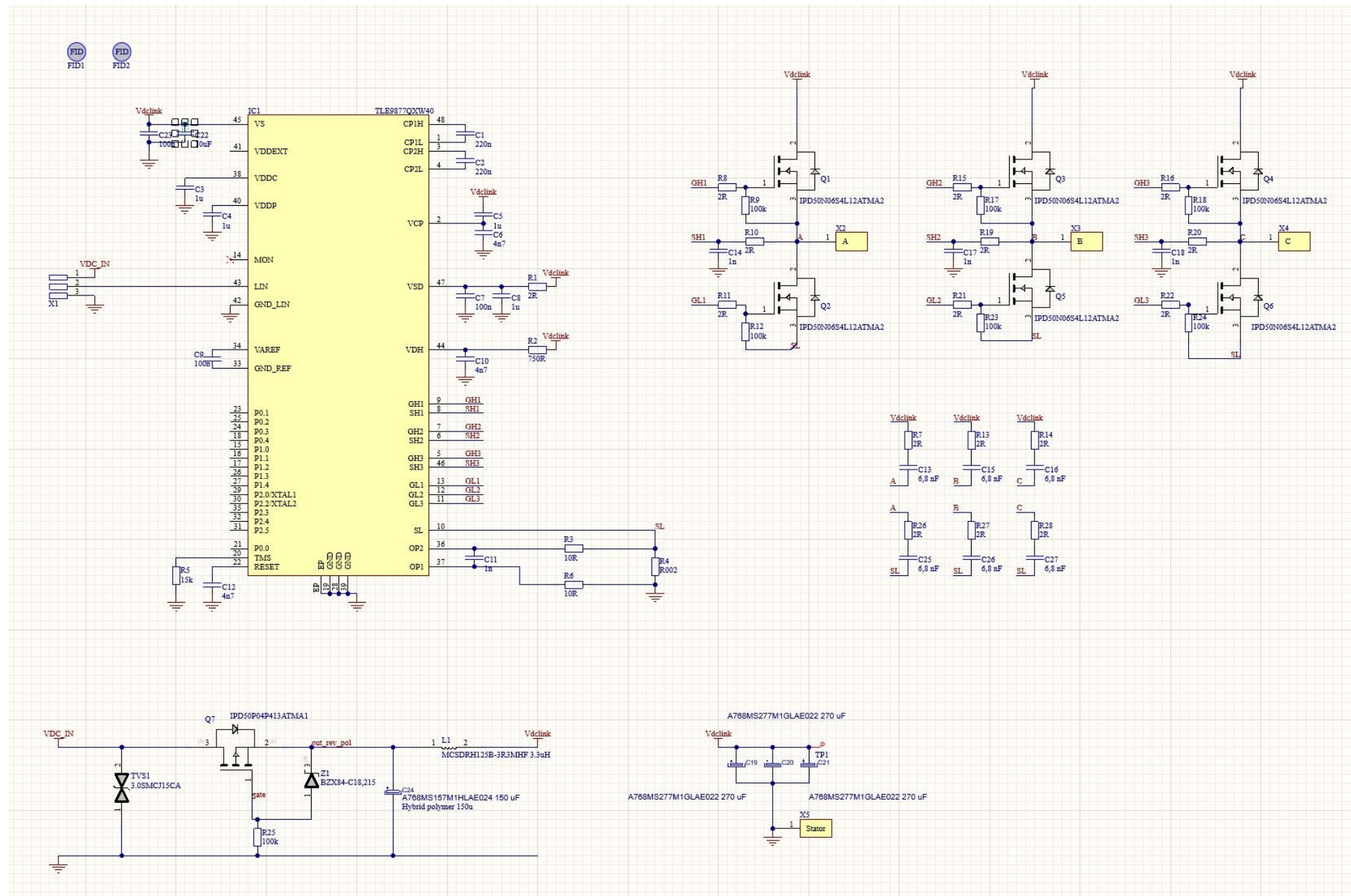

Izbira MOSFET

- IPD50N06S4L-12
- $V_{ds_max} = 60V$
- $R_{ds_on} = 9,6 m\Omega$
- $I_d = 50 A$



Dual MOSFETs (3.127)



Single MOSFETs (25.282)



Kondenzatorji DC link

- Polymer aluminum
- PANASONIC 35SVT120M
- $C = 3 \times 120\mu\text{F}$
- ESR: $18\text{ m}\Omega$ (/3)
- Iripple = $4,4\text{ A}$ (*3)

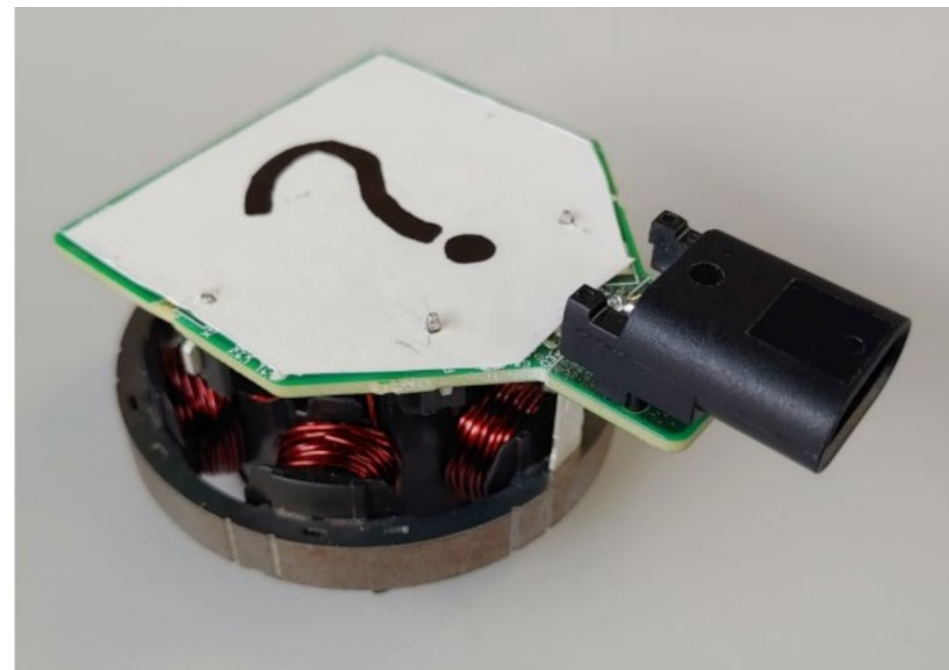

Filter

My EMI Filter project

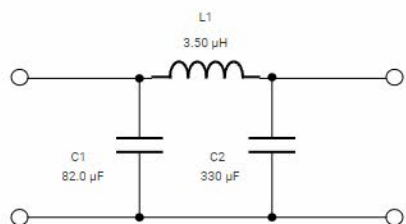

C1		82.0 µF	16.0 V	15.8 mΩ	
L1		3.50 µH	10.2 A	8.00 mΩ	
C2		330 µF	16.0 V	9.50 mΩ	

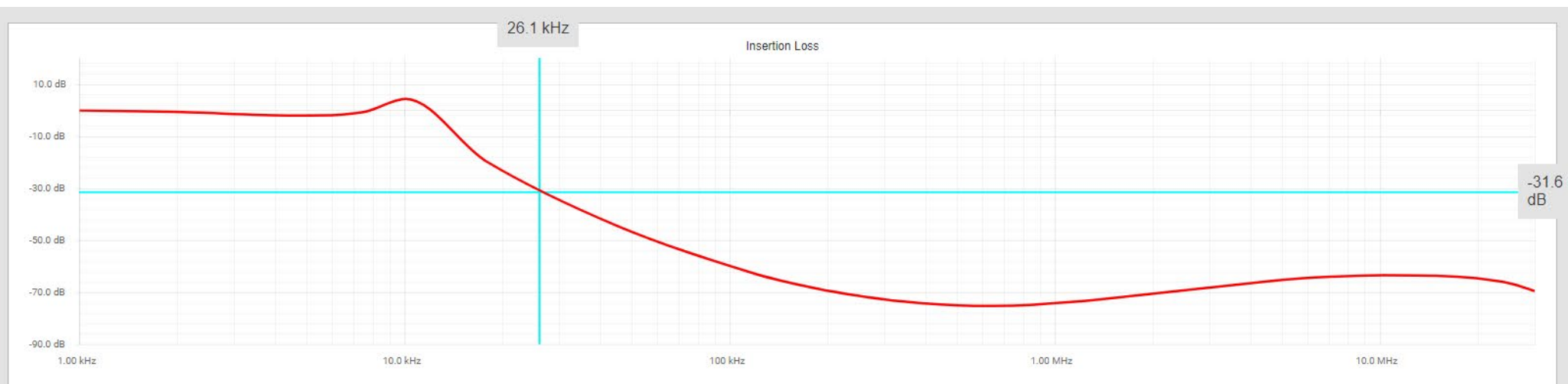

My EMI Filter project

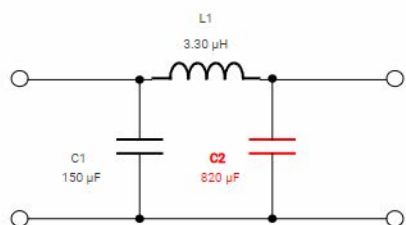

C1		150 µF	16.0 V	18.9 mΩ	
L1		3.30 µH	7.50 A	8.90 mΩ	
C2		820 µF	16.0 V	7.84 mΩ	



Razpored komponent

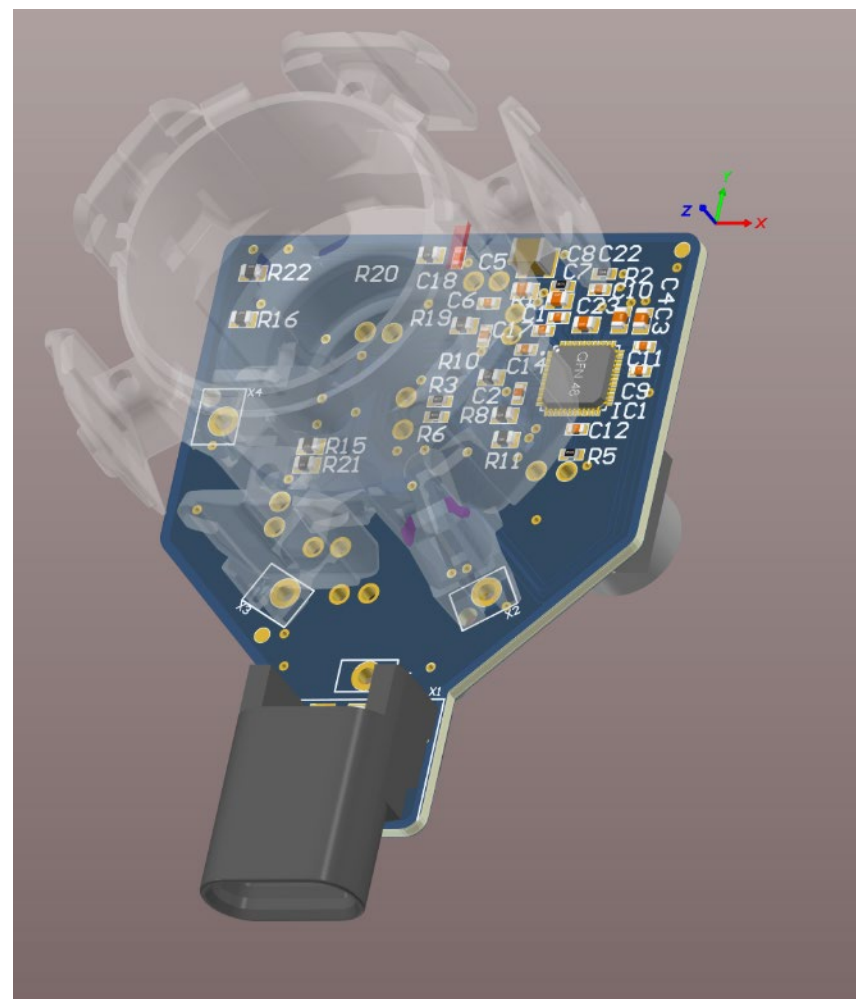
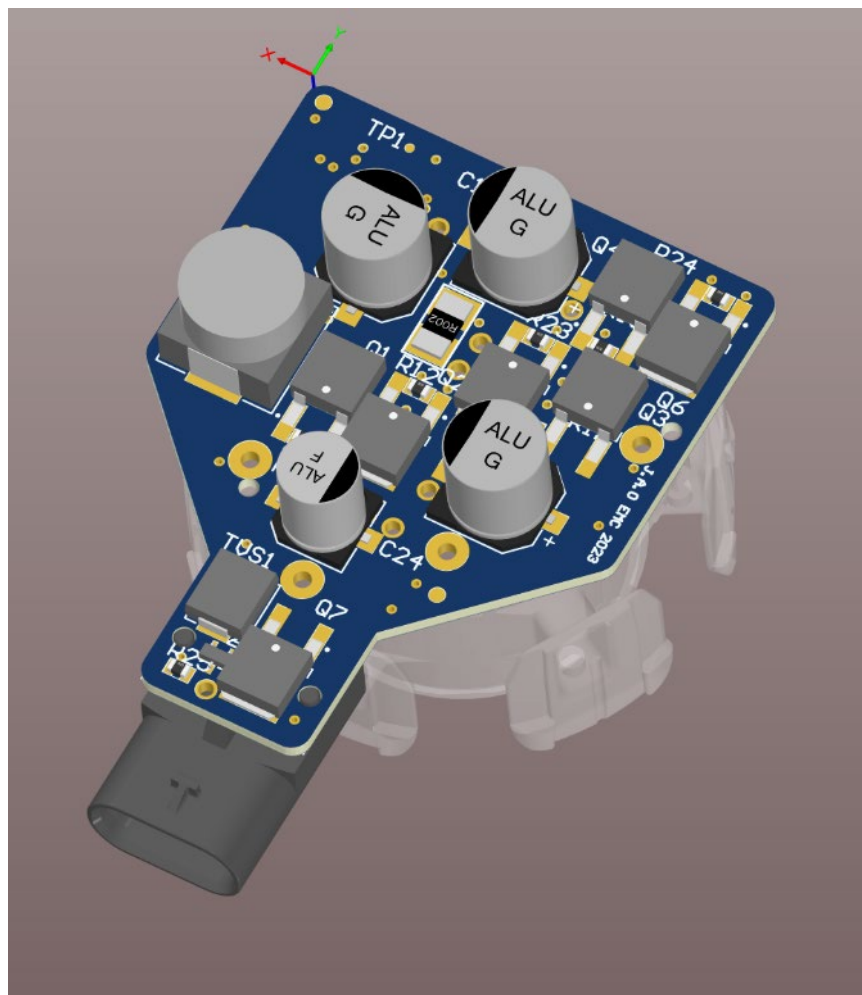

Tiskano vezje

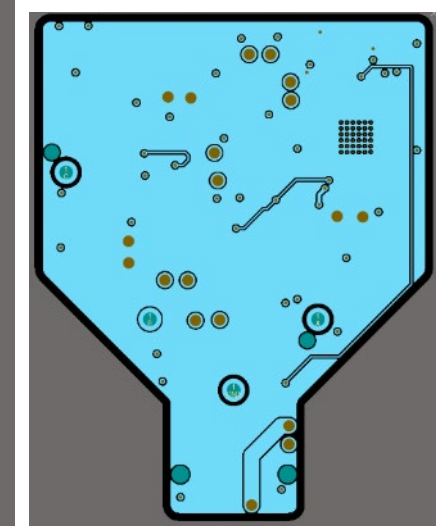
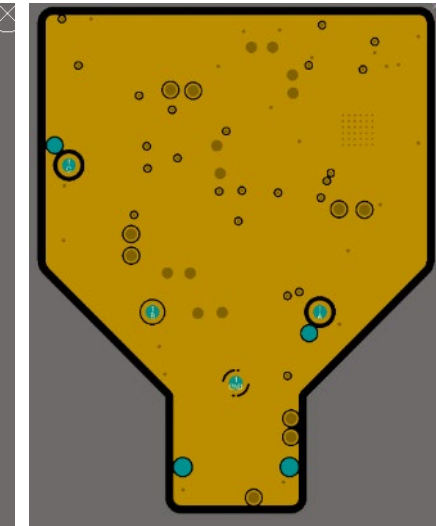
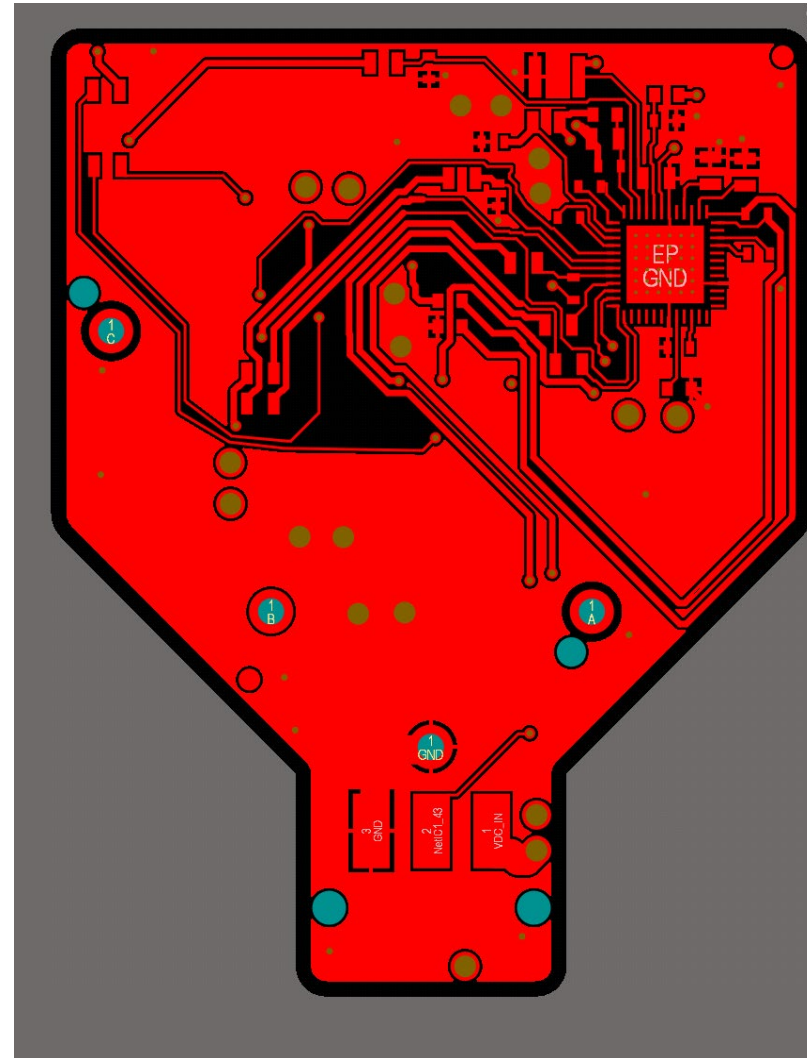
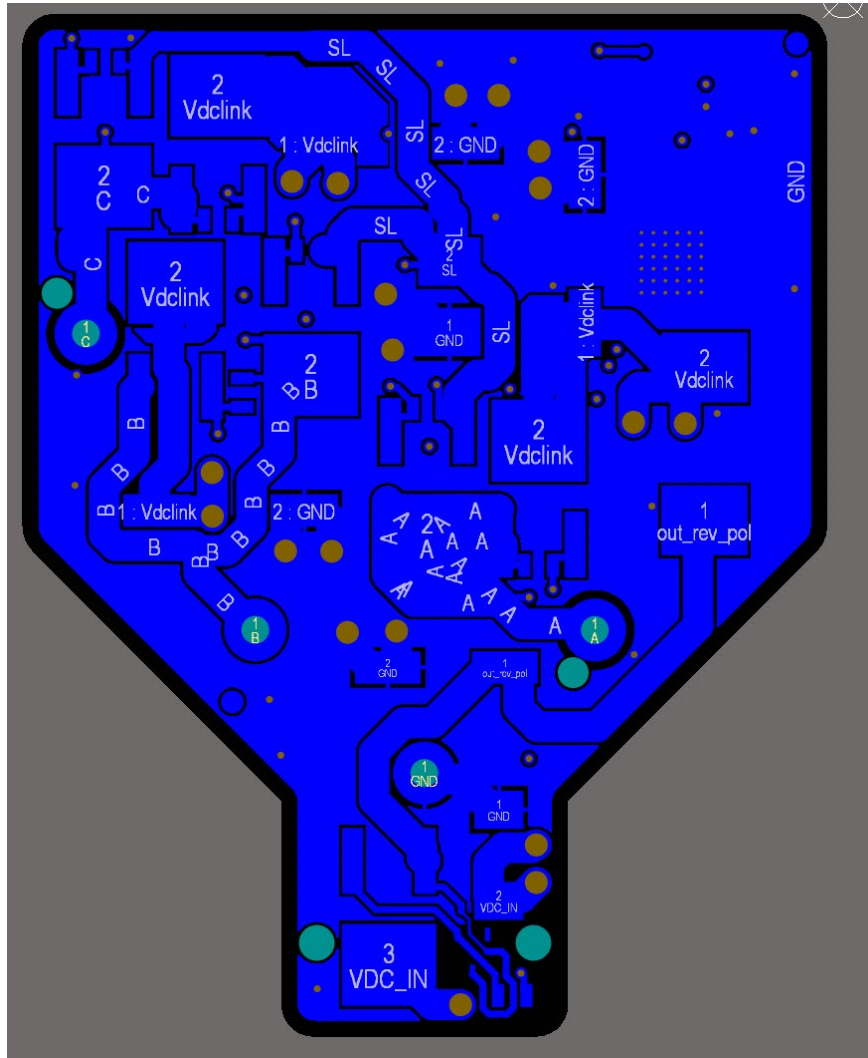

Vezje 1.0 deluje



Cilji za vezje 2.0

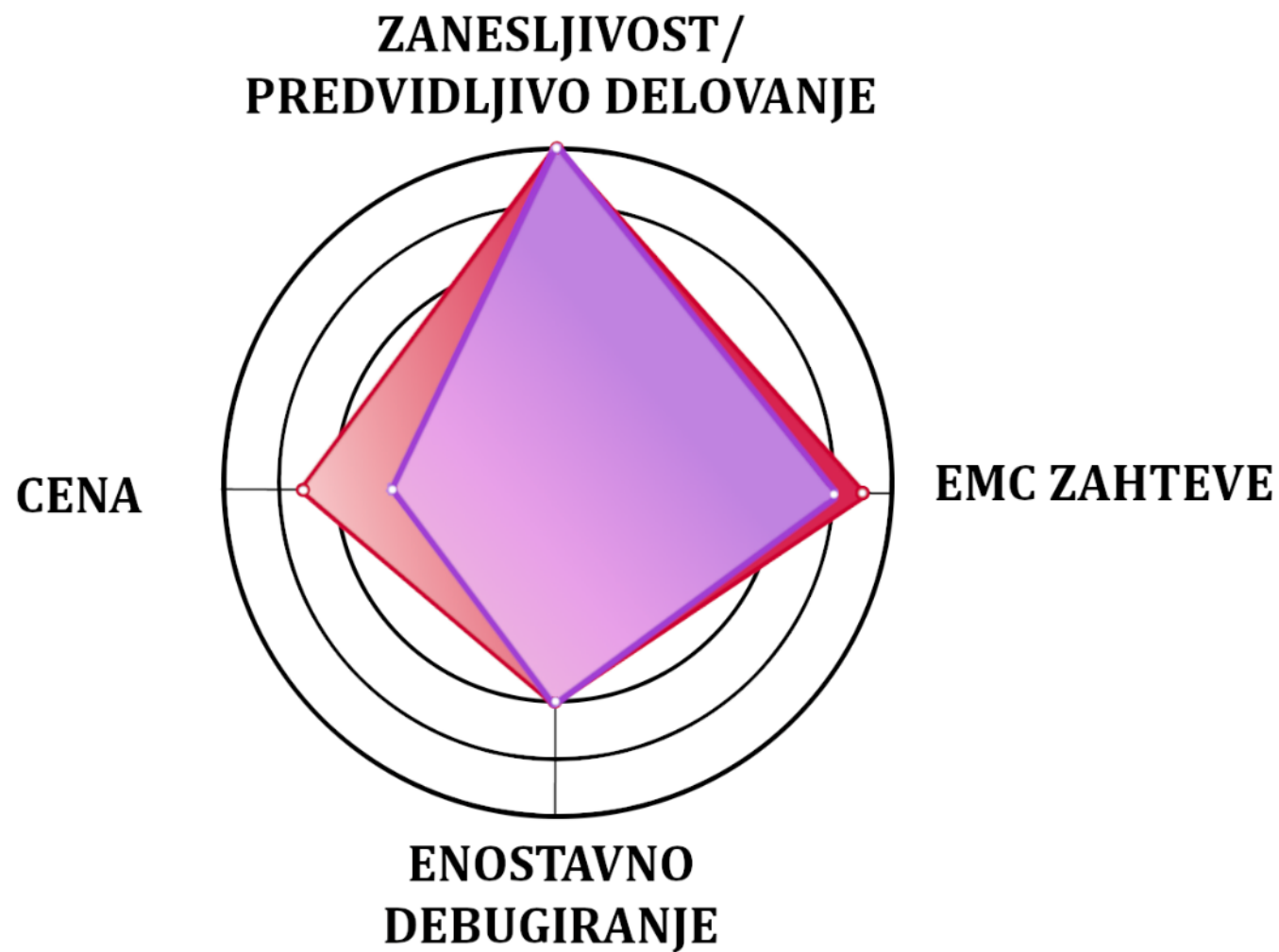

Spremembe na vezju 2.0

- Cdc_link 3* 120 uF → 3* 270 uF
- Cpi_filt 82 uF → 150 uF
- Lpi_filt 3,5 uH → 3,3 uF
- „Snuberji“

- Vezje 1.0: **11,60 EUR**
- Vezje 2.0: **5,8 EUR**

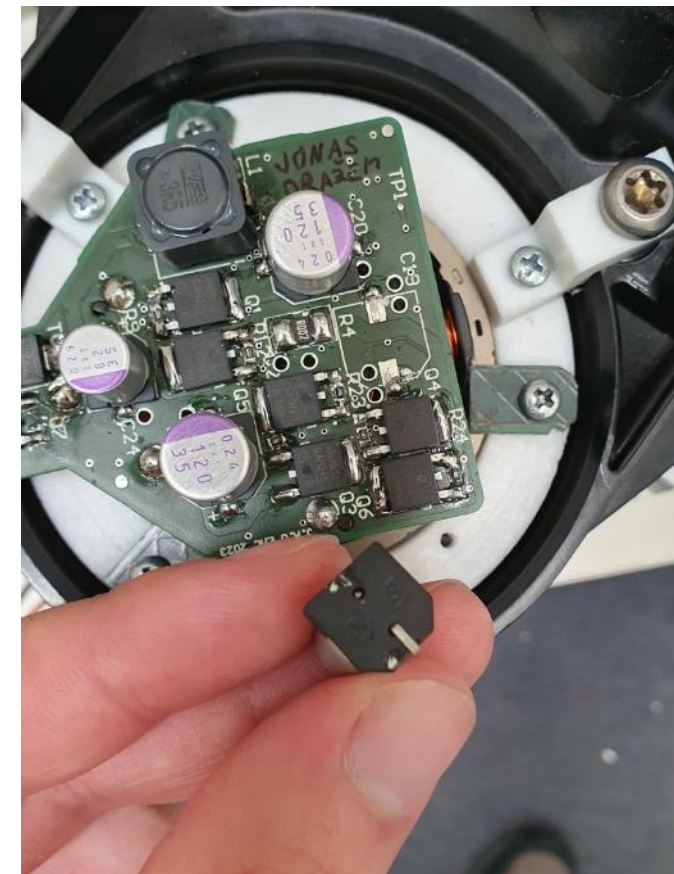

Preliminarne meritve za vezje 2

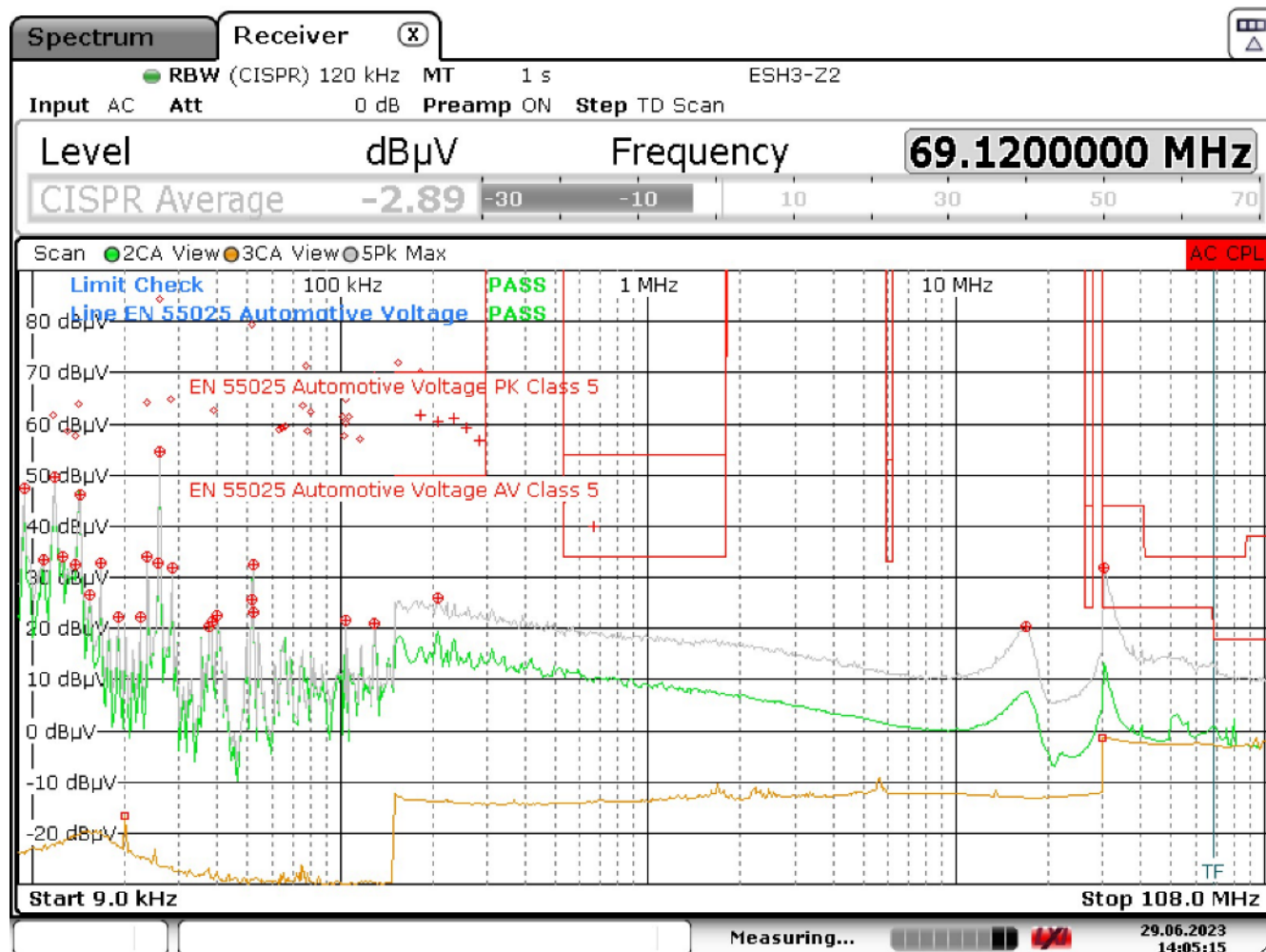

Date: 29.JUN.2023 14:05:16

Konduktivne motnje: zel-AVG, sivo-peak



Hvala za pozornost

- In srečno!

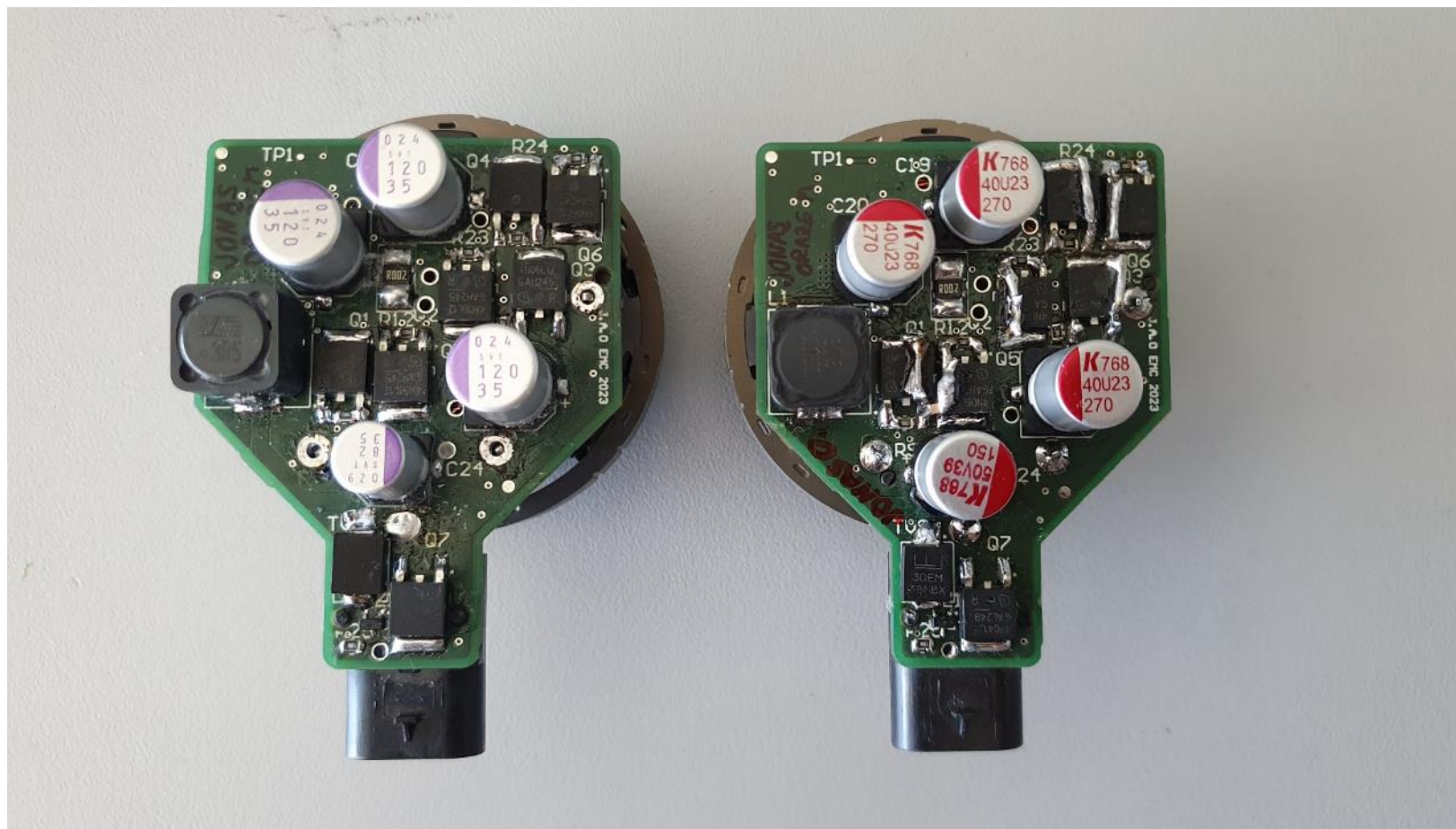

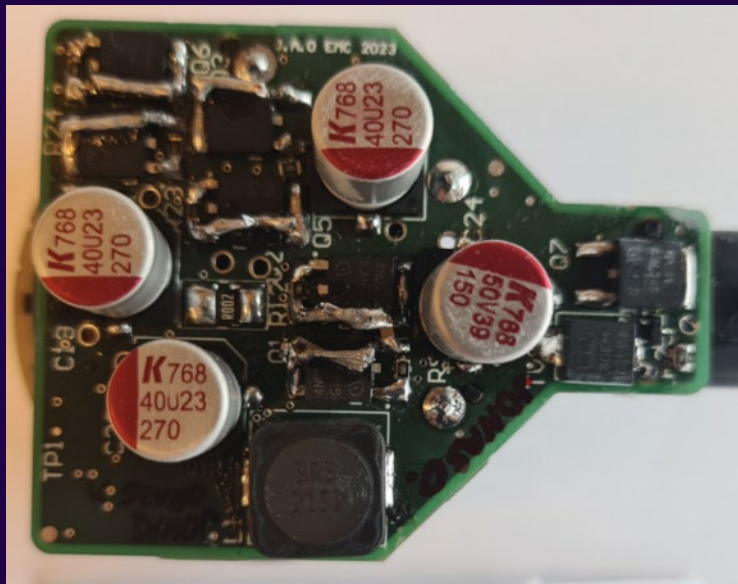

KOLEKTOR



Rezultati

Jonas Oražem

Jonas Oražem

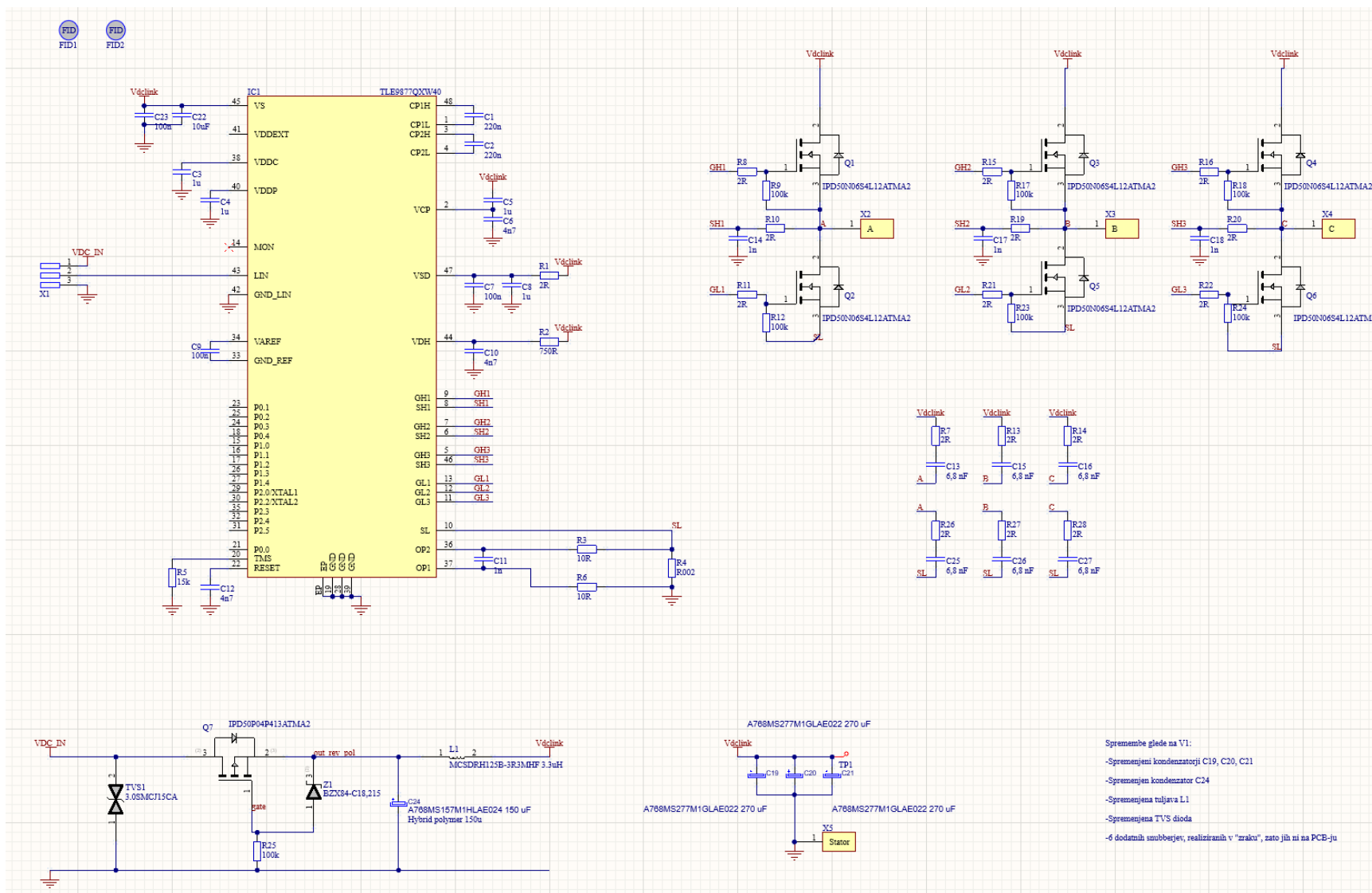

Jonas Oražem

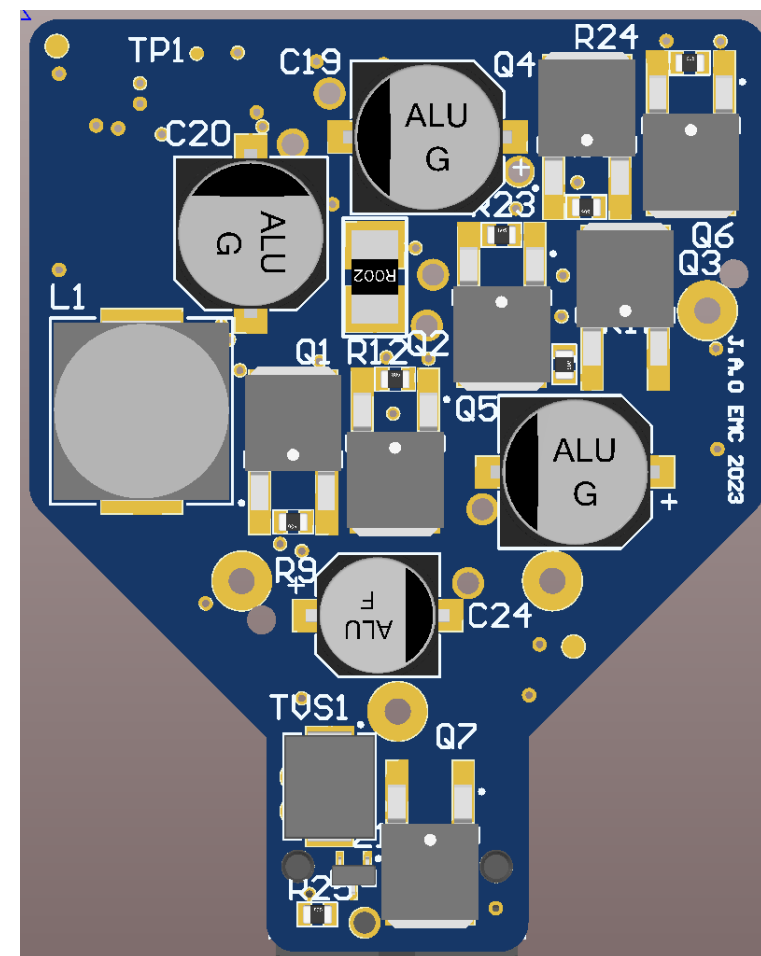
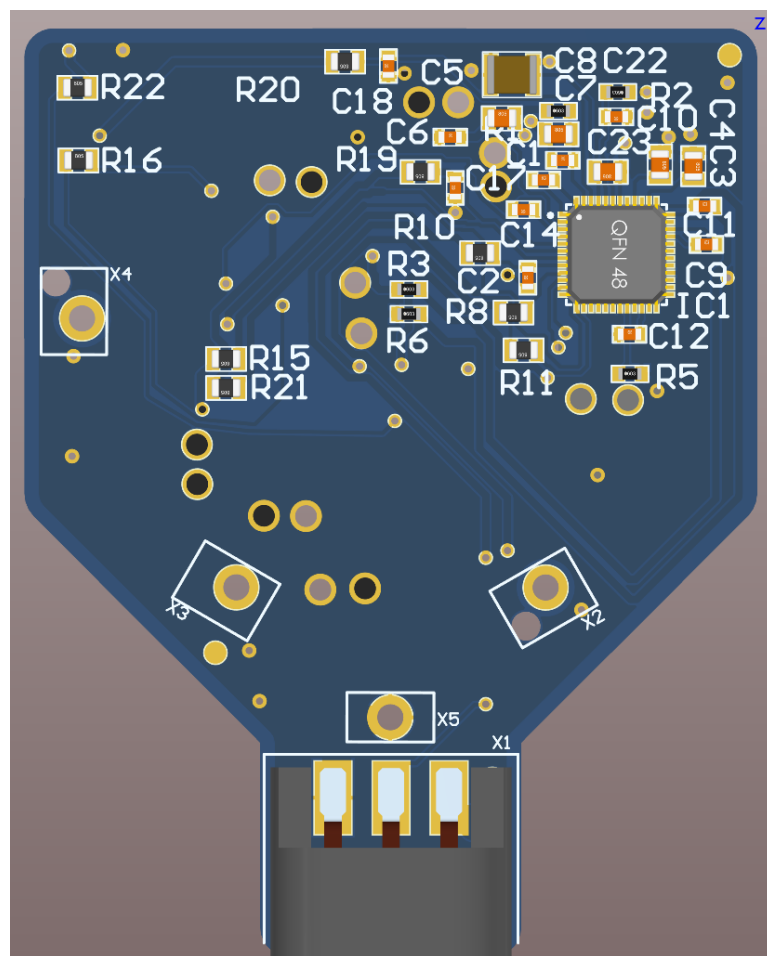

Jonas Oražem

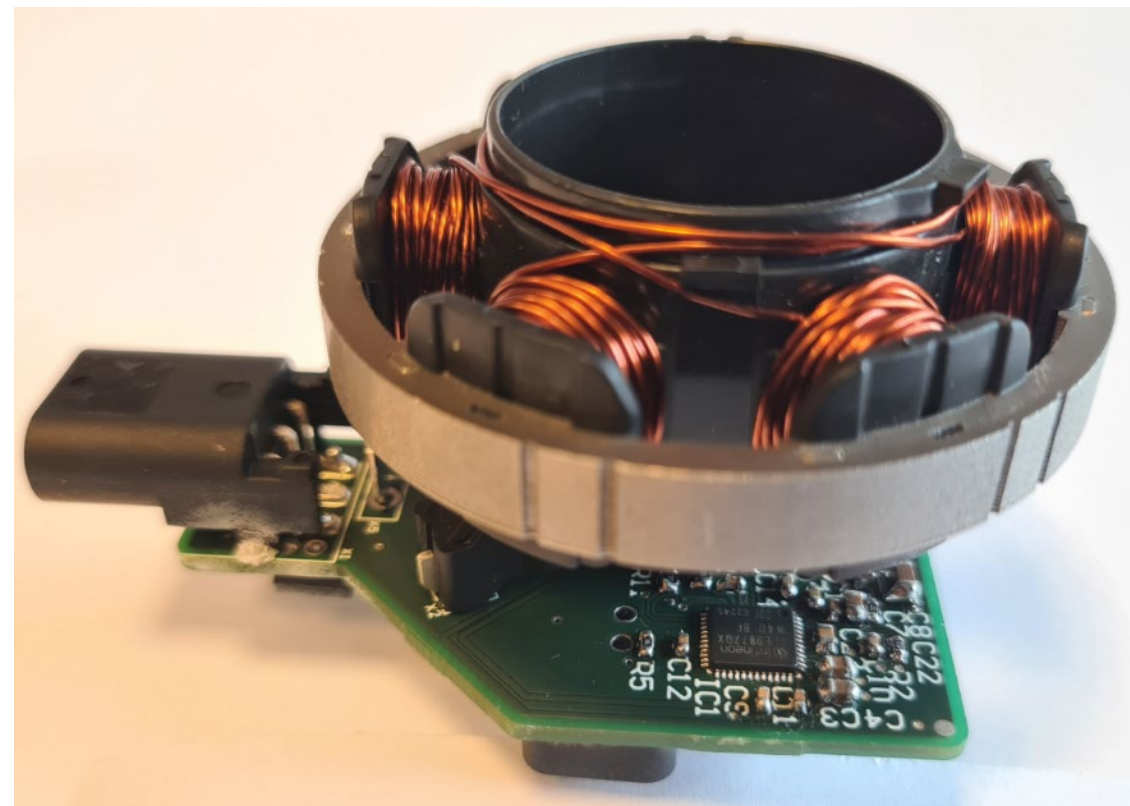
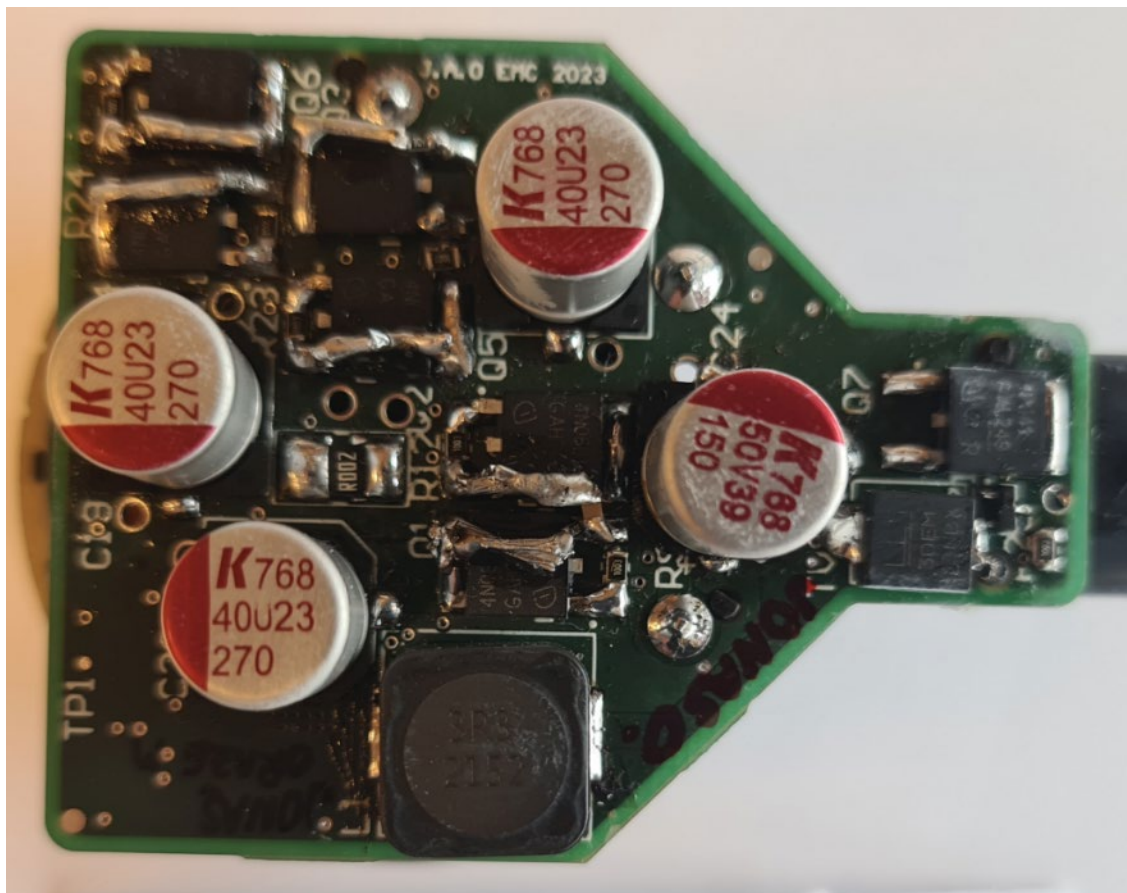

Jonas Oražem

No.	Query	Qty	Matches	Part	Part Description	Distributor/SKU	Unit Price	Line Total	Batch Total	Notes
1	A768MS157M1HL	1	✔	KEMET A768MS157M1HLAE024	Cap Aluminum Polymer 150uF 50V 20% Solder Cylindrical 24m Ohm 2150mA 2000 hr	Mouser 80-A768MS157M1HLAE24 Stock: 97 Tape & Reel	0,2860	0,2860	286,0000	
2	A768MS277M1GL	3	✔	KEMET A768MS277M1GLAE022	Cap Aluminum Polymer 270uF 40V 20% Solder Cylindrical 22m Ohm 2200mA 2000 hr	Mouser 80-A768MS277M1GLAE22 Stock: 695 Tape & Reel	0,2700	0,8100	810,0000	
3	1864447	1	📄	Multicomp MCSDRH125B-3R3MHF	Ind Power Shielded Wirewound 3.3uH ±20% 100kHz Ferrite 10.8A	Newark 74AC1340 Stock: 300	0,1041	0,1041	104,0903	
4	BZX84C18-DC	1	✔	Diodes Inc. BZX84C18	Diode Zener Single 18V 6% 350mW Automotive 3-Pin SOT-23	Newark 67T1053 Stock: 5.964	0,0103	0,0103	10,3152	
5	2803392	6	✔	Infineon IPD50N06S4L12ATMA2	IPD50N06S4L Series 60 V 50 A 12 mOhm OptiMOS®-T2 Power-Transistor -PG-	Rochester Electronics IPD50N06S4L12ATMA1 Stock: 251	0,2358	1,4145	1.414,5021	
6	3290146	1	✔	Infineon IPD50P04P413ATMA2	Mosfet, Aec-Q101, P-Ch, -40V, -50A, 58W Rohs Compliant. Yes Infineon	Mouser 728-IPD50P04P413ATM Stock: 12.475 Tape & Reel	0,6230	0,6230	623,0000	

Tekmovalec	cena tranzistorjev	Cena kondenzatorjev	Cena dušilk	Cena diod	Skupaj
Jonas Oražem	2,04 €	1,10 €	0,10 €	0,01 €	3,25 €

Tekmovalec	kvalifikacija	temp. območje	ostale zahteve	Cena komponent	Točke
Jonas Oražem	3	3	3	3,25 €	-7,25

Jonas Oražem

- Izkoristek 86,33%
- Prenihaj 1,6V
- Padec napetosti 0,097 V
- Tok nasprotne polaritete 0,1 mA

Tekmovalec	Osnovna	Izkoristek	Polariteta	Padec r	Prenihaj	Točke
Jonas Oražem	12	13	5	5	5	40

Jonas Oražem - CE

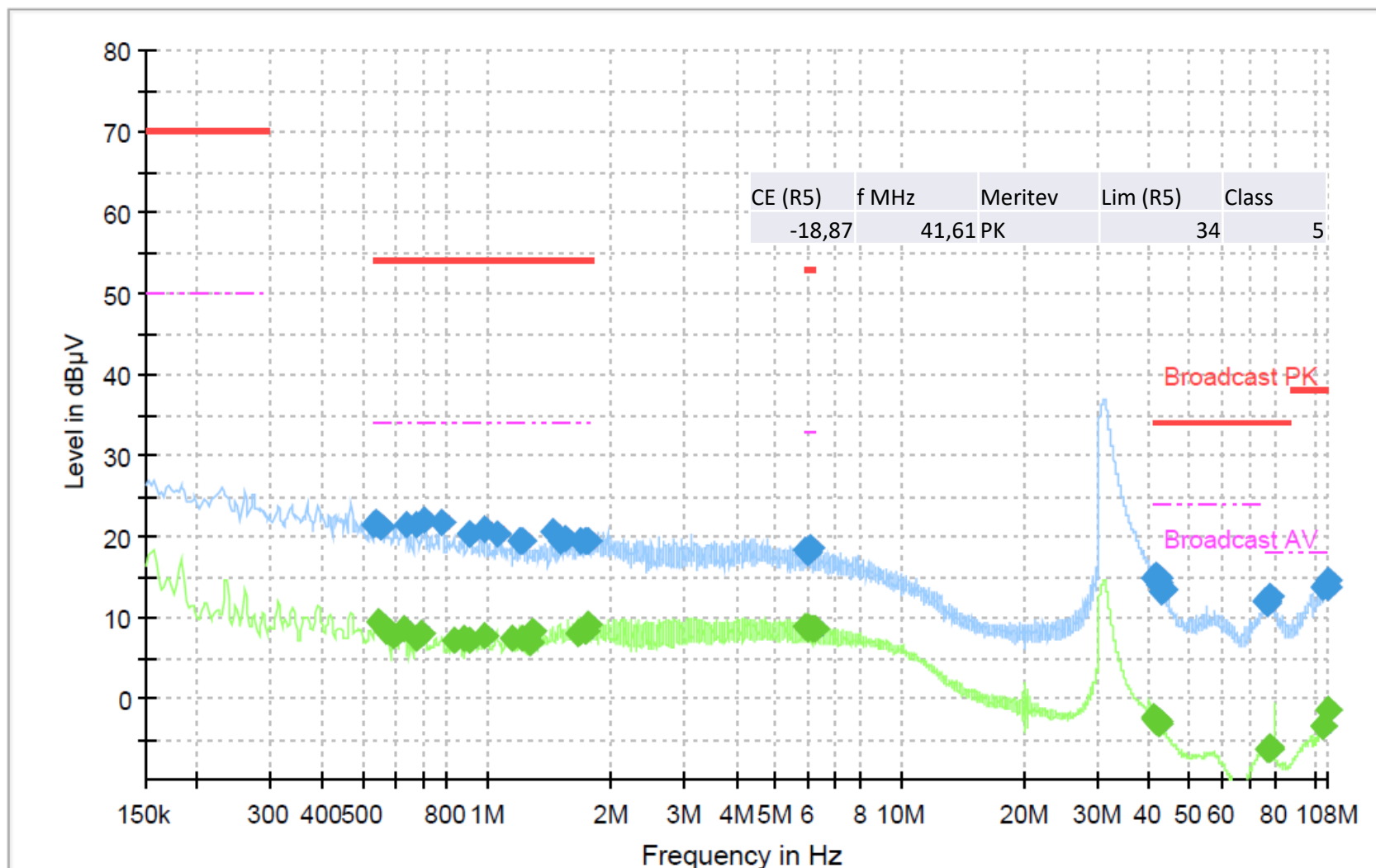

Jonas Oražem - VW

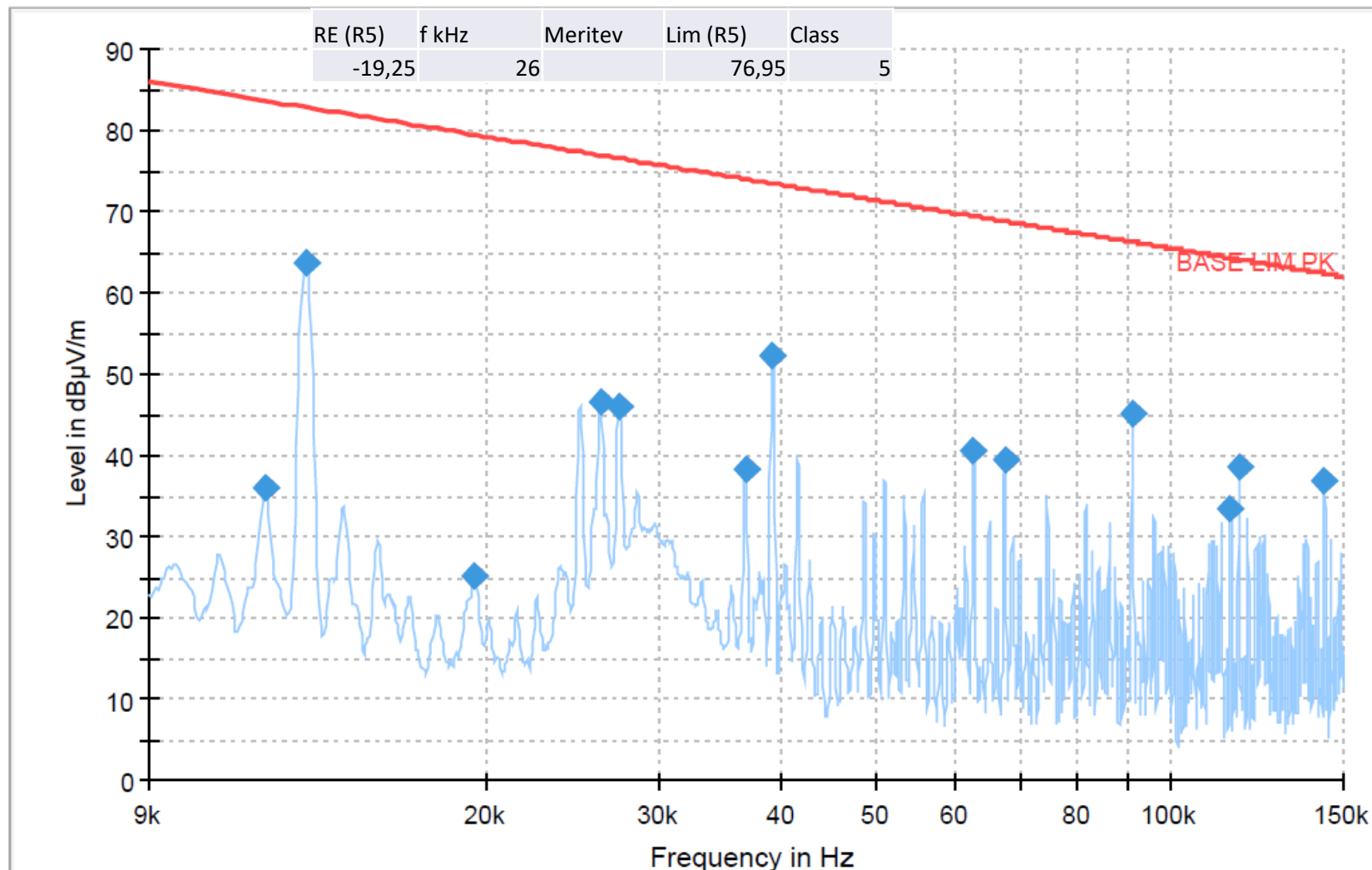

Jonas Oražem - RE

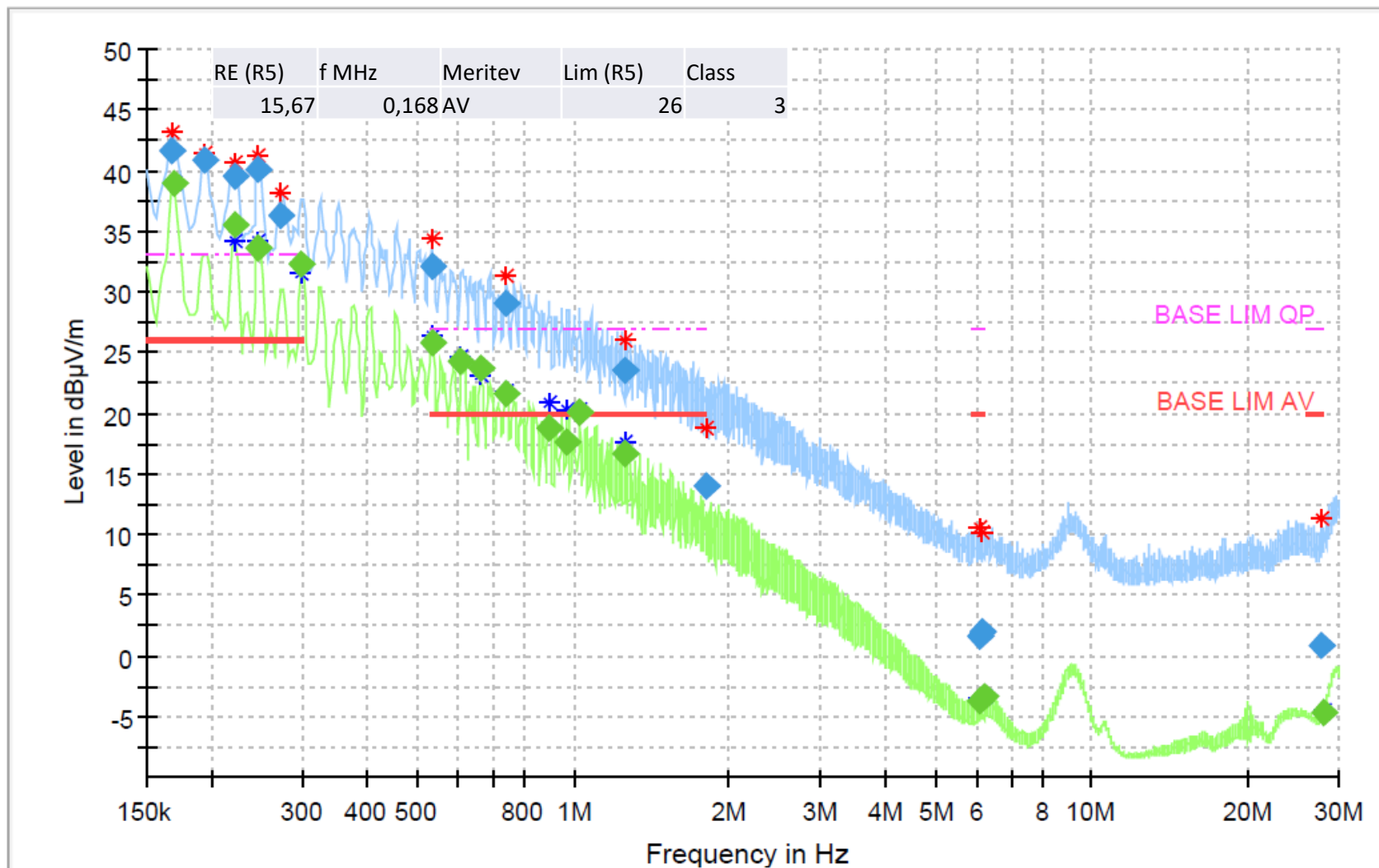

Jonas Oražem - RE

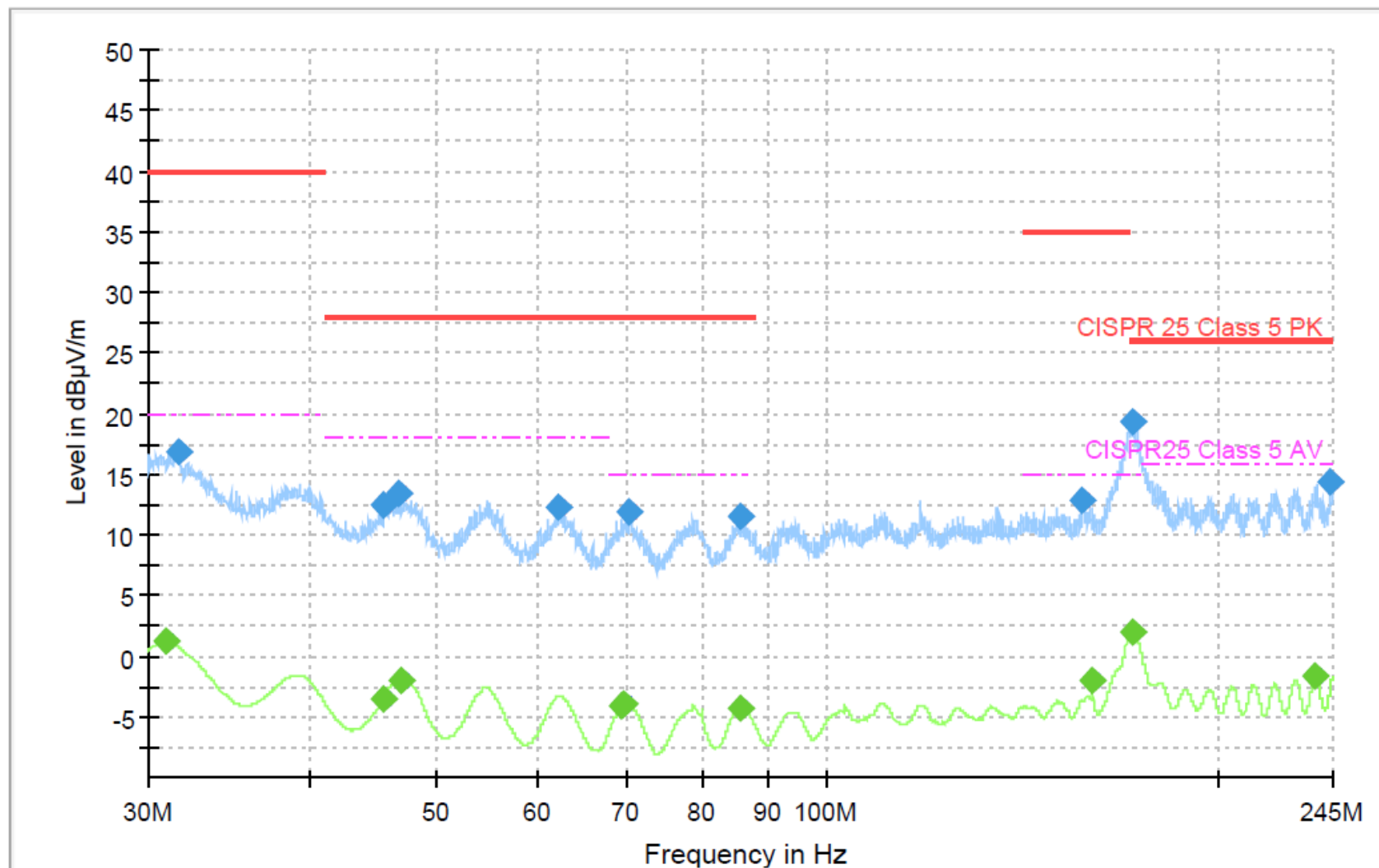

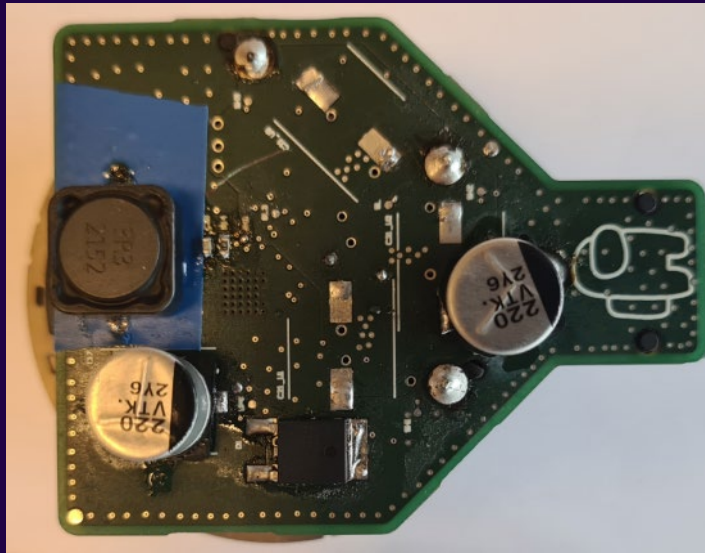

KOLEKTOR



Predstavitev

Luka Kavčič

Shema, izračuni, simulacije

Bulk kondenzatorji (C, I, R), snubber, gate, shunt

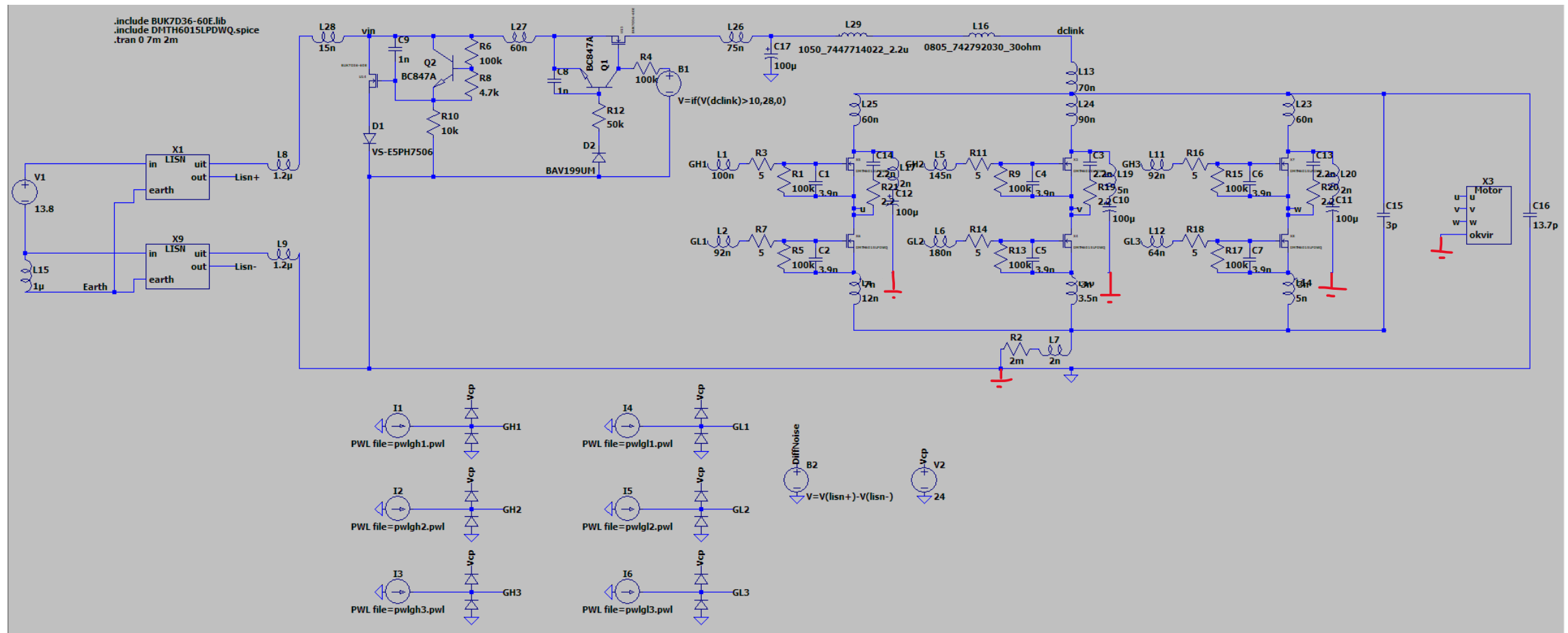

Načrt tiskanega vezja

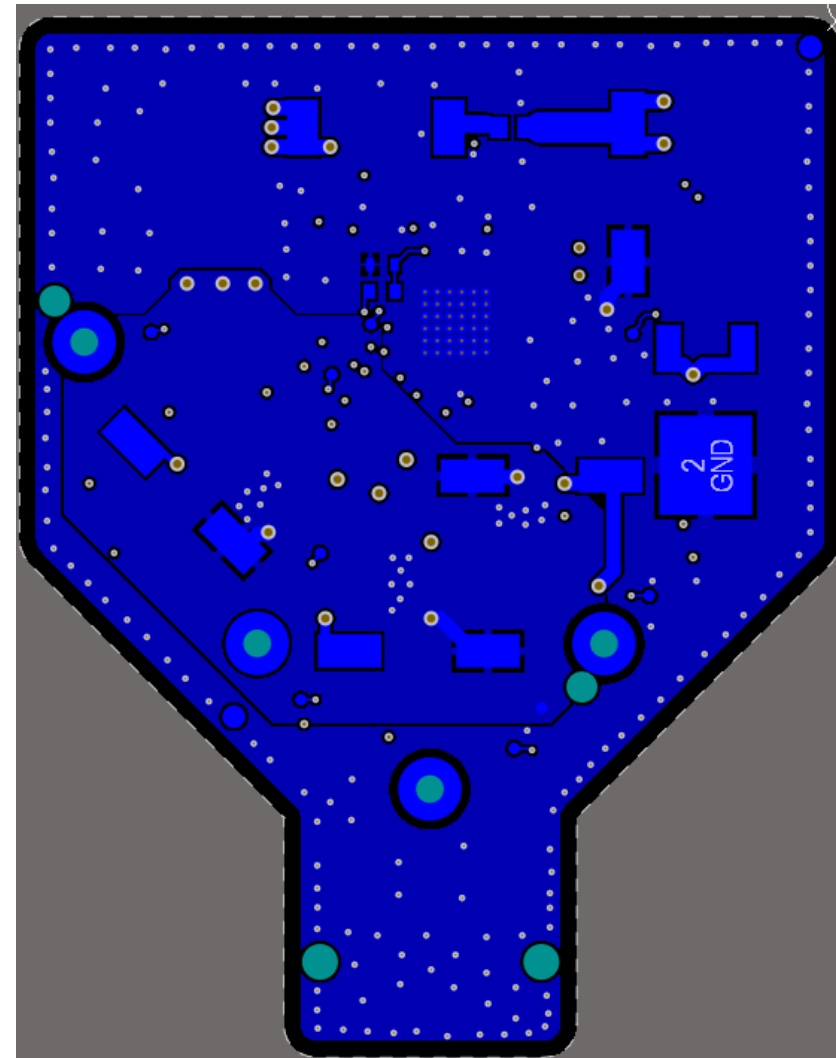
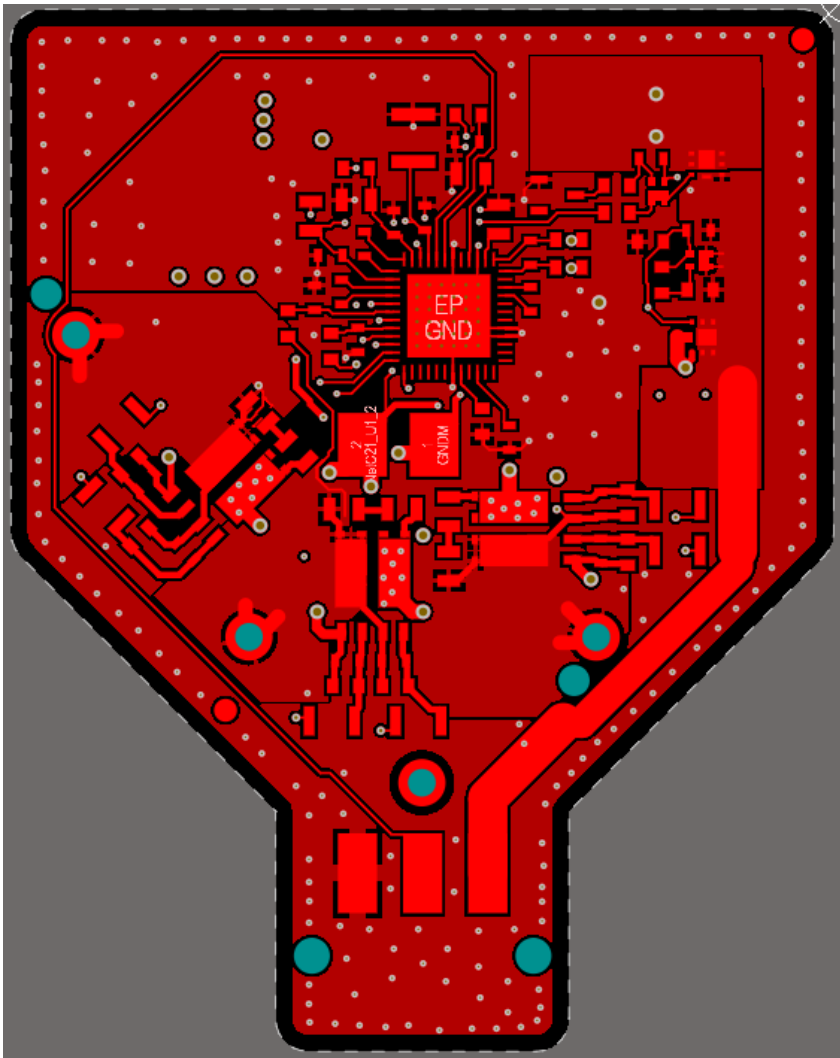

Načrt tiskanega vezja

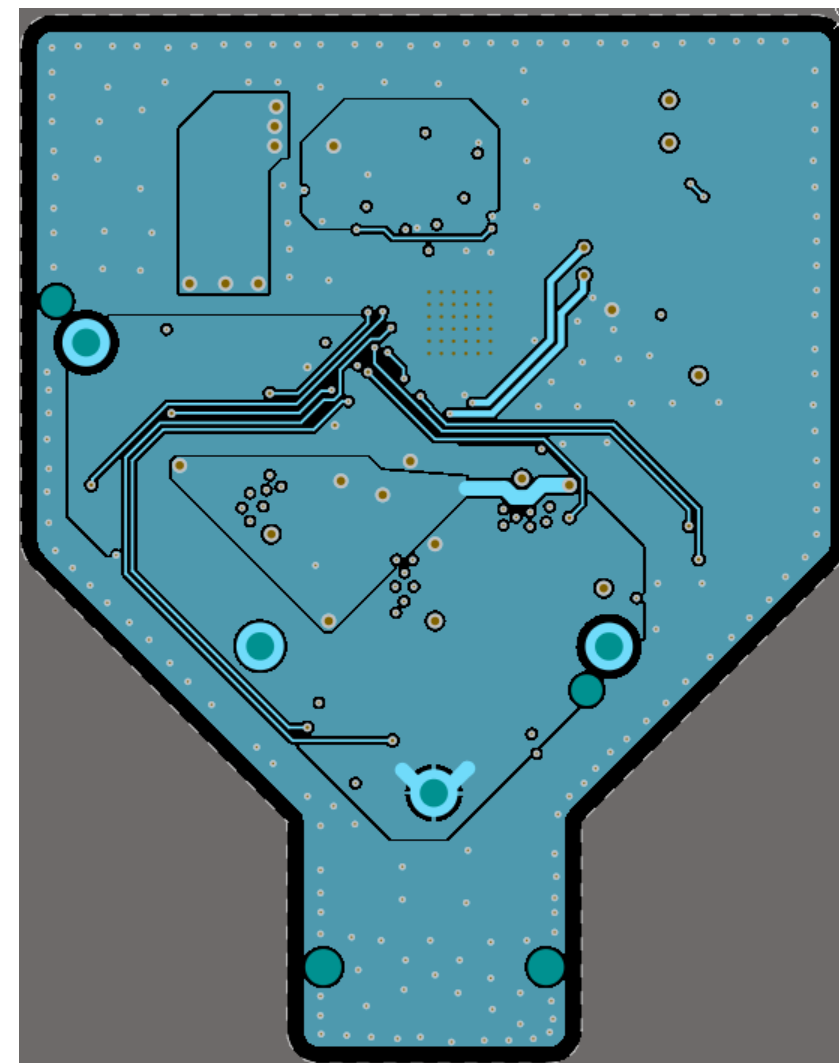
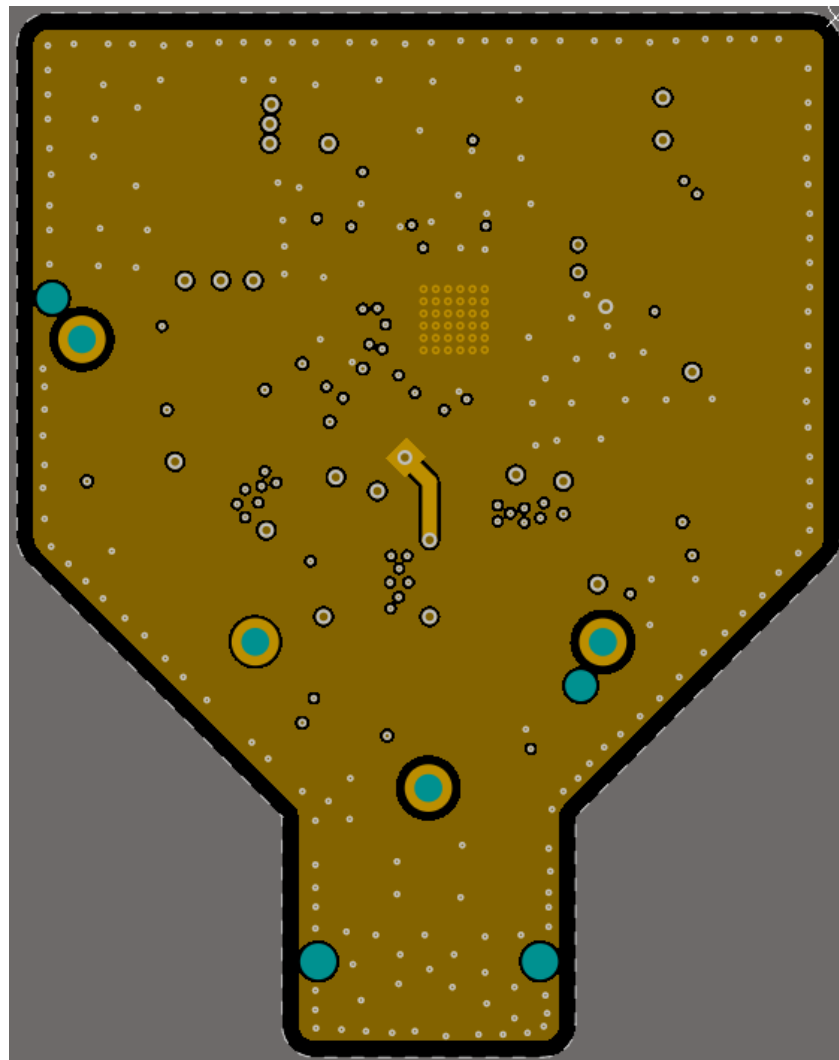

Preliminarne meritve

Razlika povezave satorja

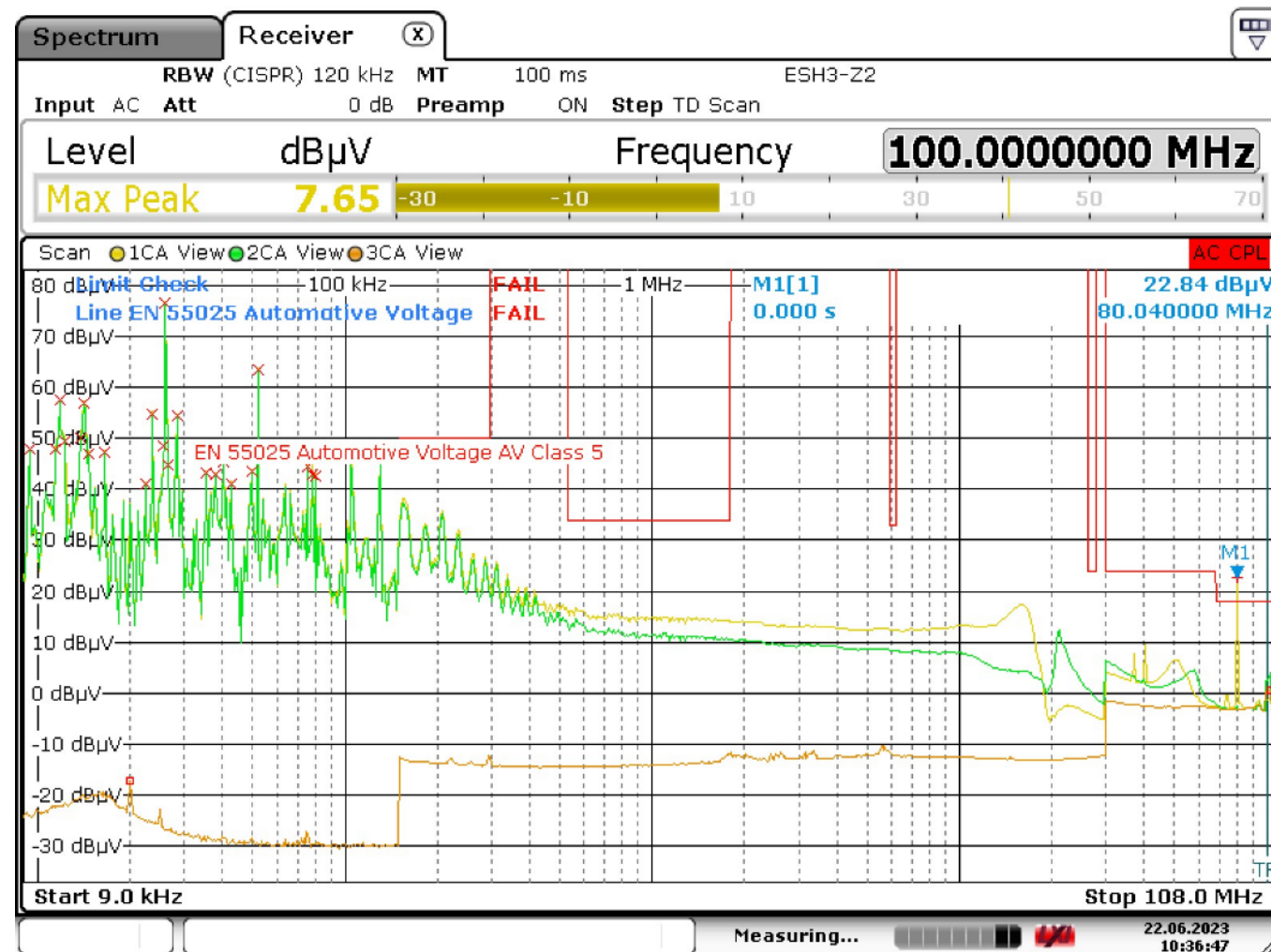

Preliminarne meritve

Razlika vrednosti kondenzatorjev: 100u vs 220u

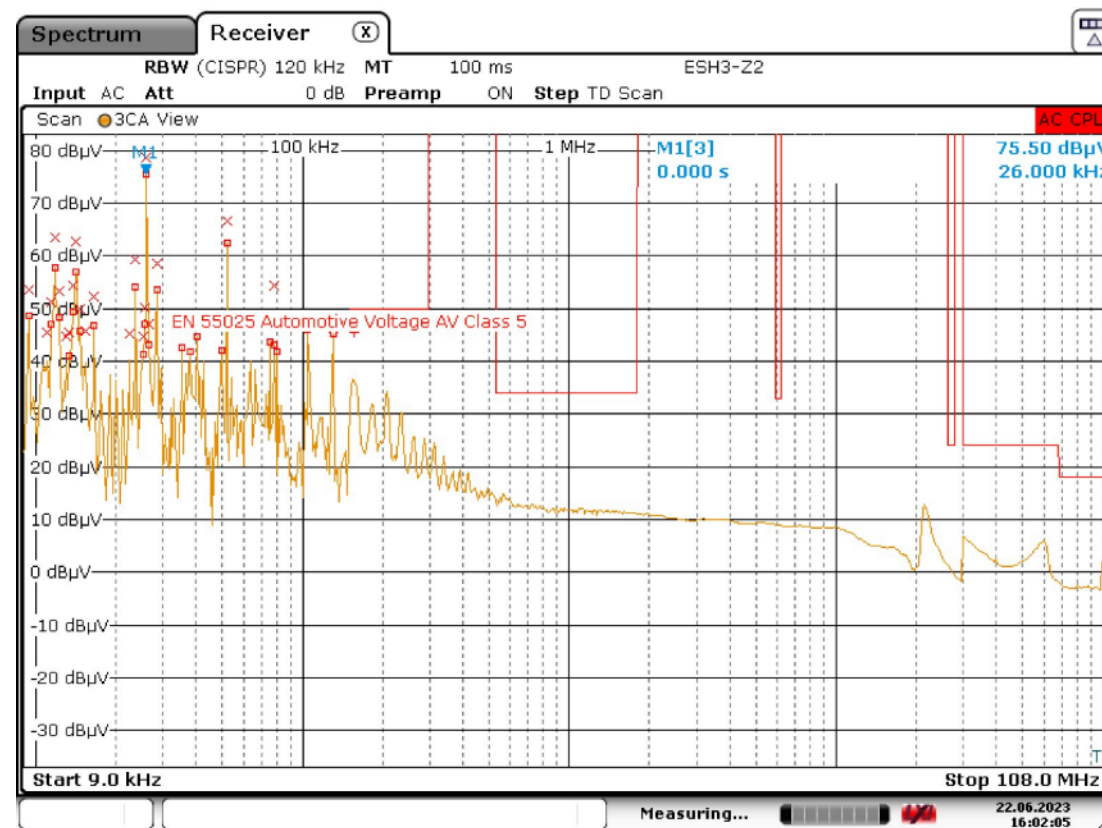

Preliminarne meritve

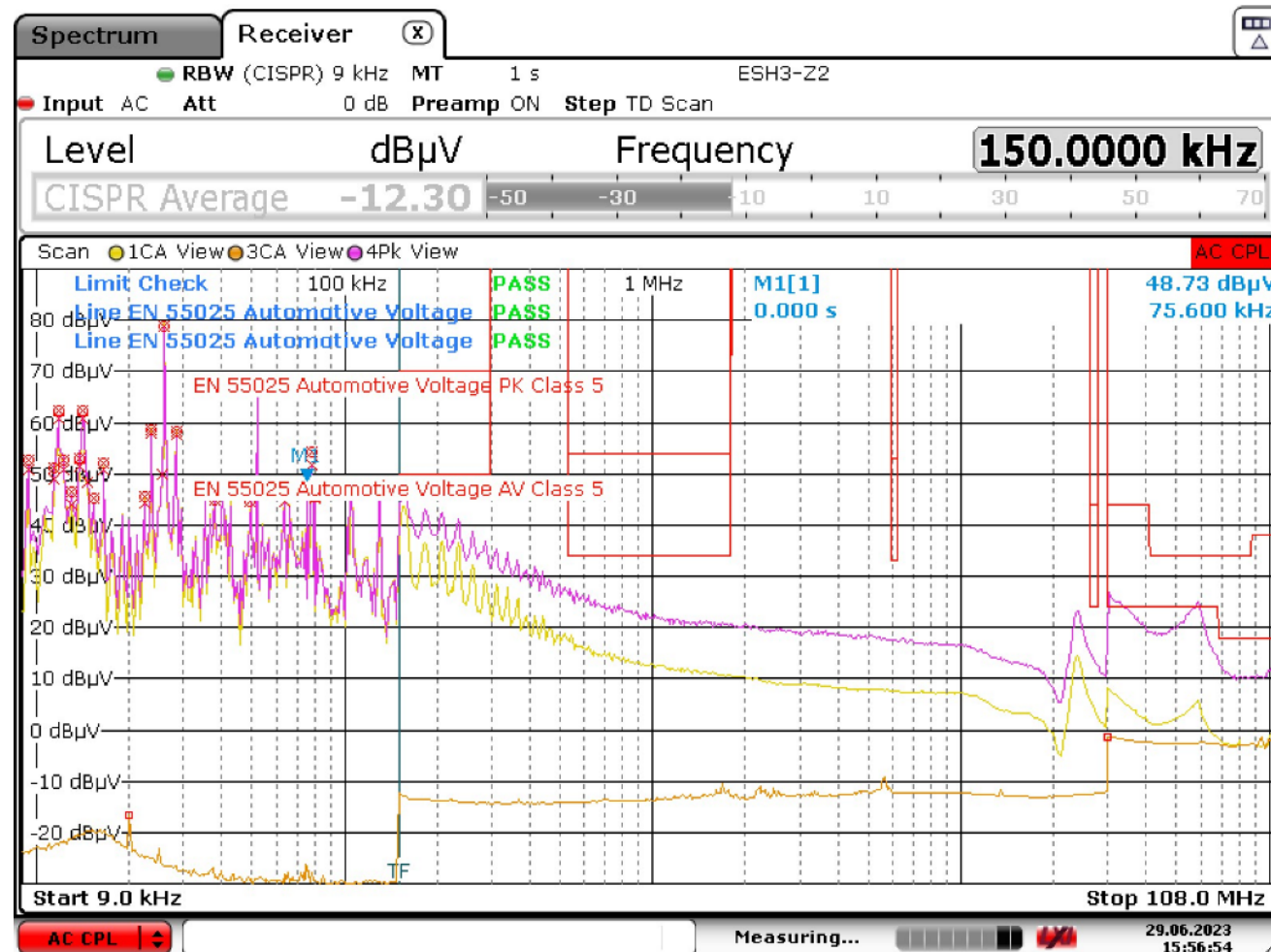

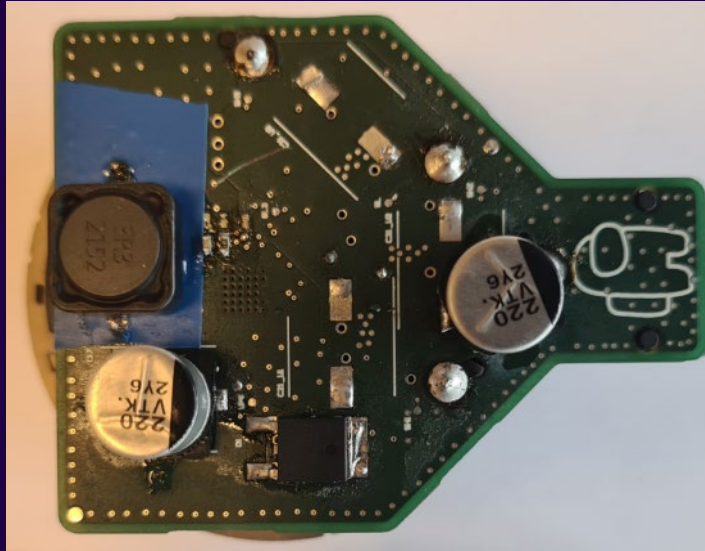

KOLEKTOR



Rezultati

Luka Kavčič

Luka Kavčič

Footprint za BC847 je mirrored, Dead-Bug

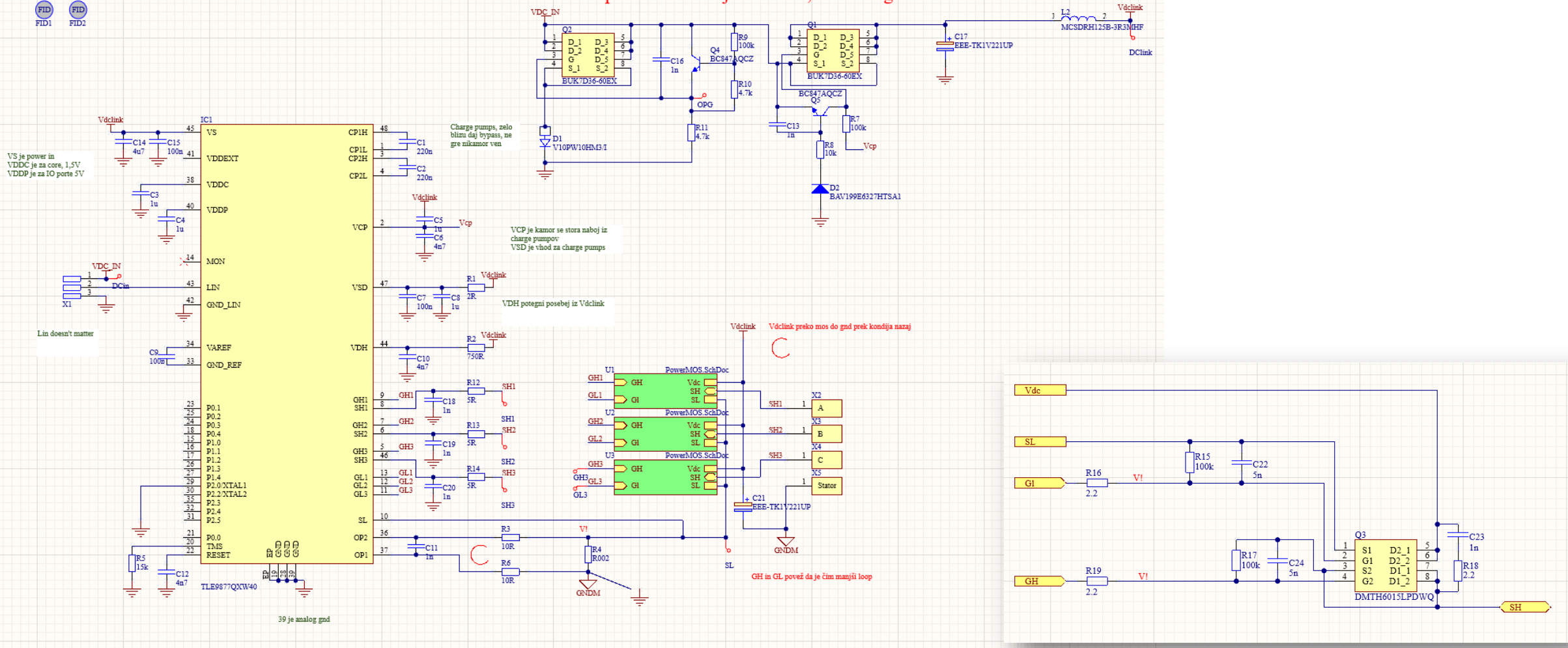

Luka Kavčič

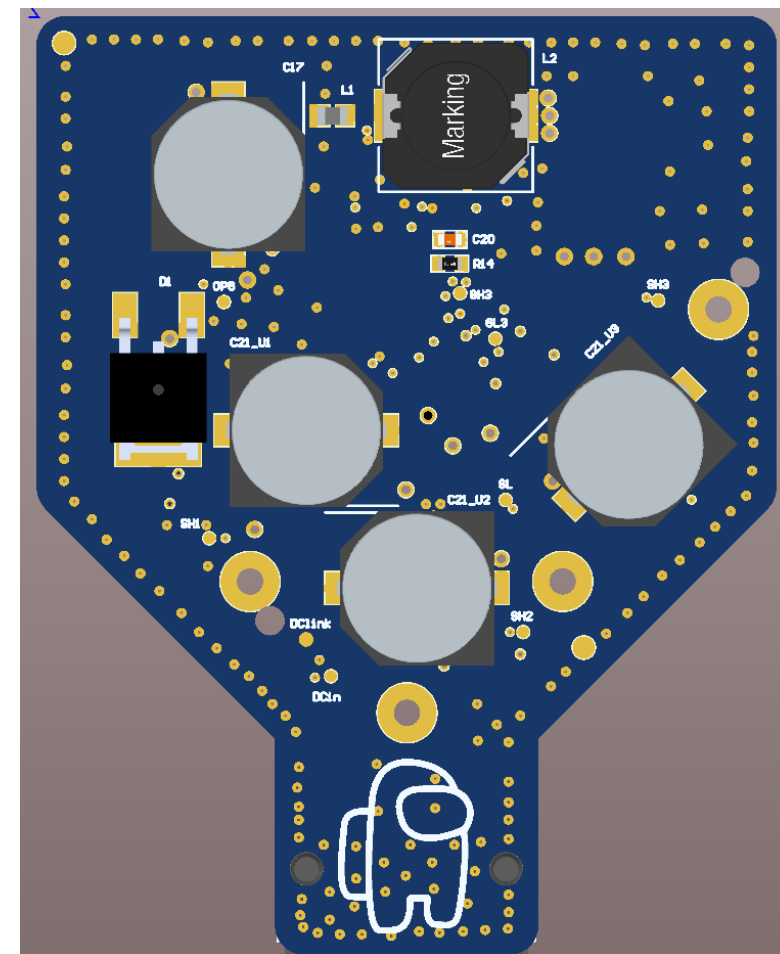
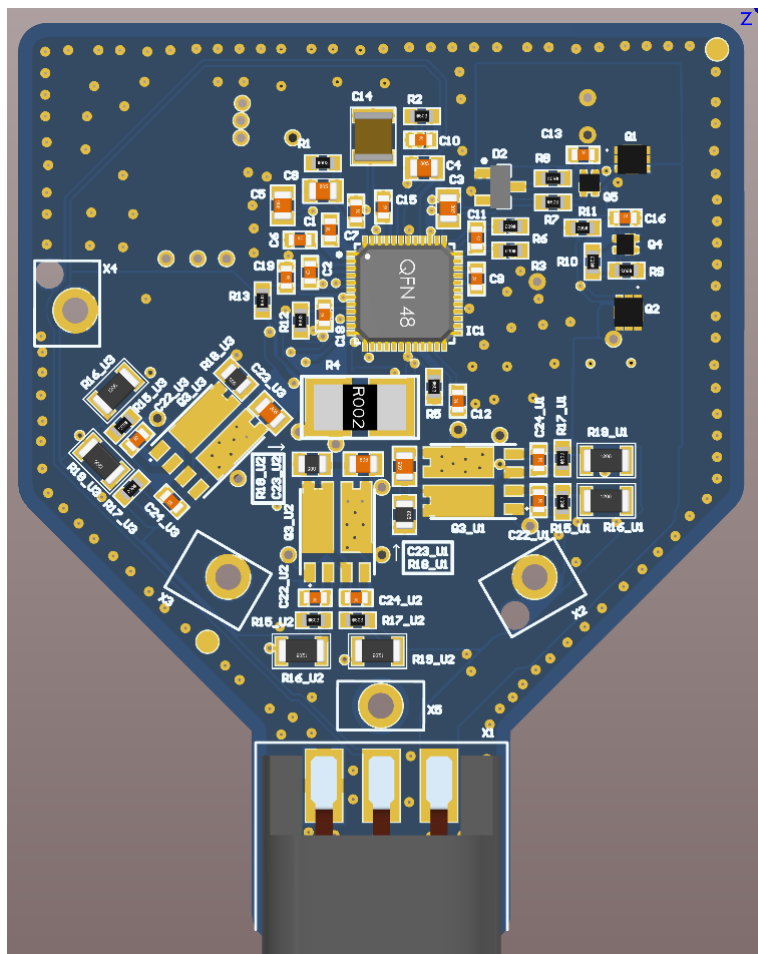

Luka Kavčič

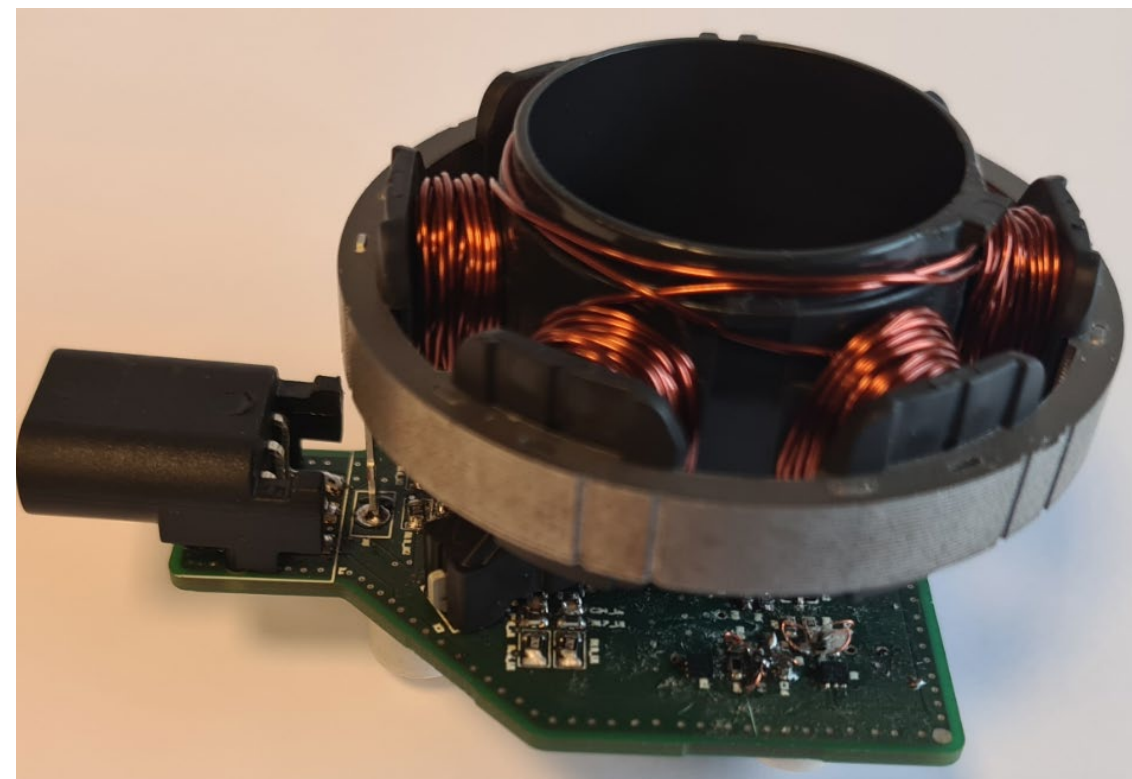
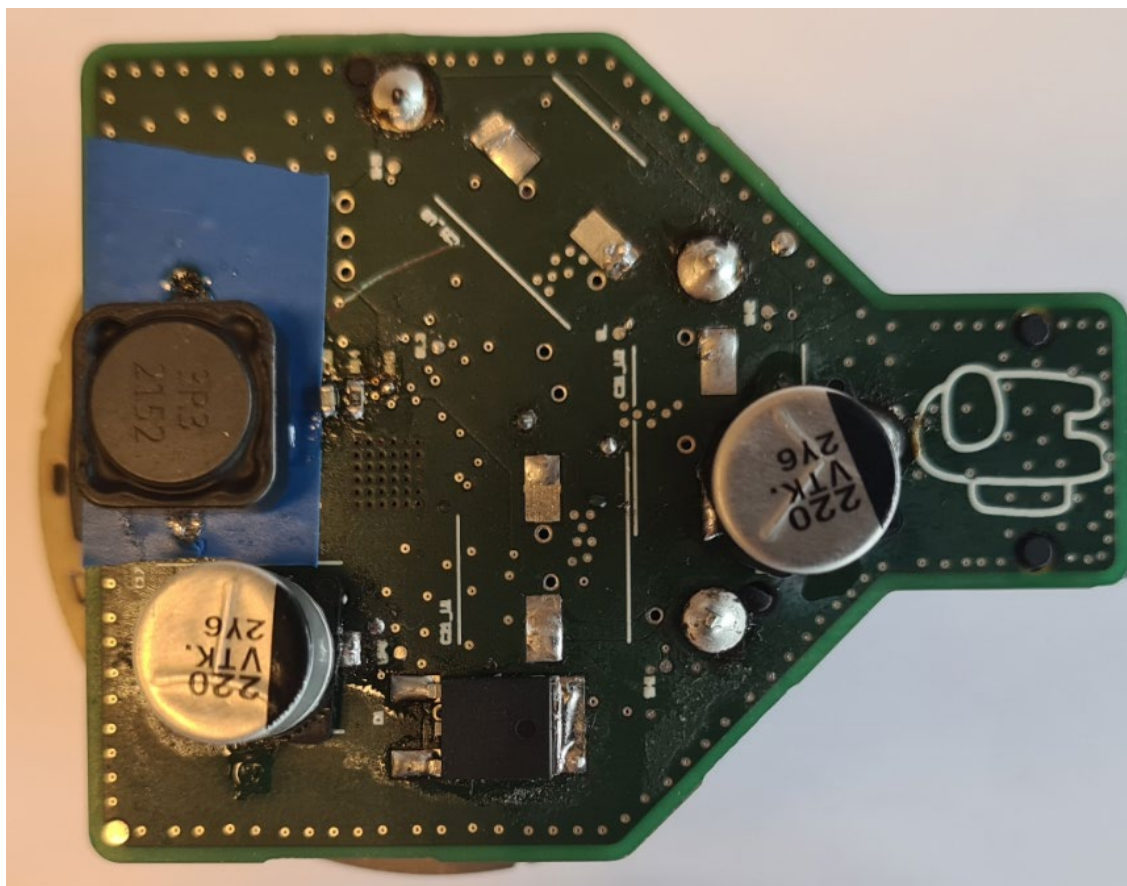

Luka Kavčič

No.	Query	Qty	Matches	Part	Part Description	Distributor/SKU	Unit Price	Line Total	Batch Total	Notes
1	74AC1340	1	✓	Multicomp MCSDRH125B-3R3MHF	Ind Power Shielded Wirewound 3.3uH ±20% 100kHz Ferrite 10.8A	Newark 74AC1340 Stock: 300	0,1041	0,1041	104,0903	
2	3702818	3	✓	Diodes Inc. DMTH6015LPDWQ-13	Mosfet, Dual, N-Ch/60V/36.3A /Powerdi5060 Rohs Compliant: Yes Diodes Inc.	DigiKey 31-DMTH6015LPDWQ-13T... Stock: 0 Tape & Reel	0,3313	0,9938	993,7800	
3	771-BUK7D36-60E	2	✓	Nexperia BUK7D36-60EX	Mosfet, N-Ch, 60V, 14A, Dfn2020Md Rohs Compliant: Yes Nexperia BUK7D36-60EX	Farnell 3438518 Stock: 3.864	0,1330	0,2660	266,0000	
4	3748631	2	📄	Nexperia BC847AQCZ	Bipolar Transistor, Npn, 45V, Dfn1412D Rohs Compliant: Yes Nexperia BC847AQCZ	Farnell 3748631 Stock: 0	0,0170	0,0340	34,0000	
5	3818775	1	✓	Vishay V10PW10HM3/I	Schottky Rectifier, 100V, 10A, To-252Ae Rohs Compliant: Yes Vishay V10PW10HM3/I	Mouser 78-V10PW10HM3/I Stock: 4.200 Tape & Reel	0,3330	0,3330	333,0000	
6	EEE-TK1V221UP	2	✓	Panasonic EEE-TK1V221UP	Aluminum Electrolytic Capacitor, 220 uF, 35 V, ± 20%, 3000 hours @ 125°C, Radial	TTI EEE-TK1V221UP Stock: 500 Tape & Reel	0,4220	0,8440	843,9750	

Tekmovalec	cena tranzistorjev	Cena kondenzatorjev	Cena dušilk	Cena diod	Skupaj
Luka Kavčič	1,30 €	0,84 €	0,10 €	0,33 €	2,58 €

Tekmovalec	kvalifikacija	temp. območje	ostale zahteve	Cena komponent	Točke
Luka Kavčič	3	3	3	2,58 €	-3,9

Luka Kavčič - delovanje

- Izkoristek 83,77 %
- Prenihaj 2,00 V
- Padec napetosti 0,168 V
- Tok nasprotne polaritete 3,8 mA

Tekmovalec	Osnovna	Izkoristek	Polariteta	Padec r	Prenihaj	Točke
Luka Kavčič	12	8	5	5	5	35

Luka Kavčič - CE

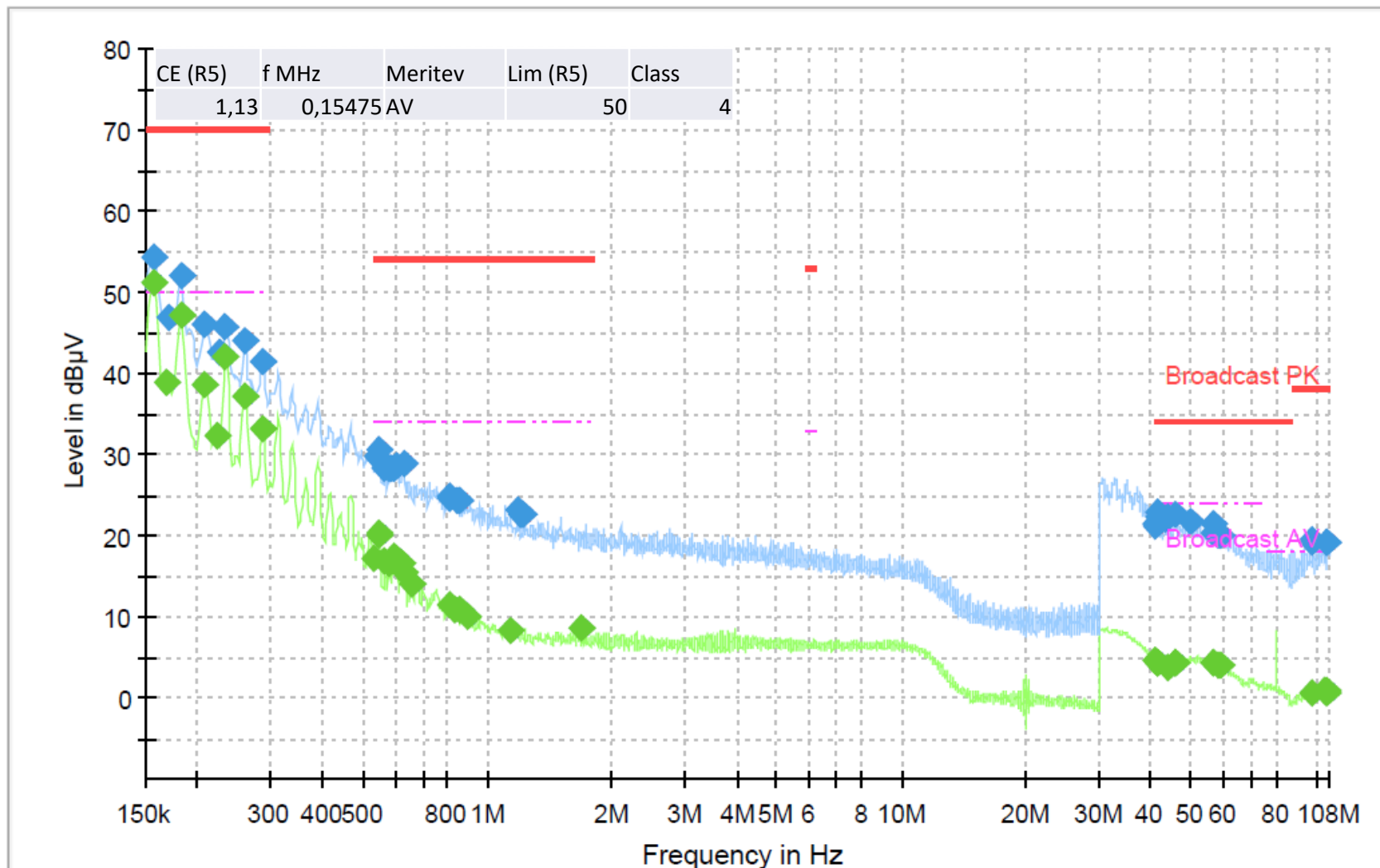

Luka Kavčič - VW

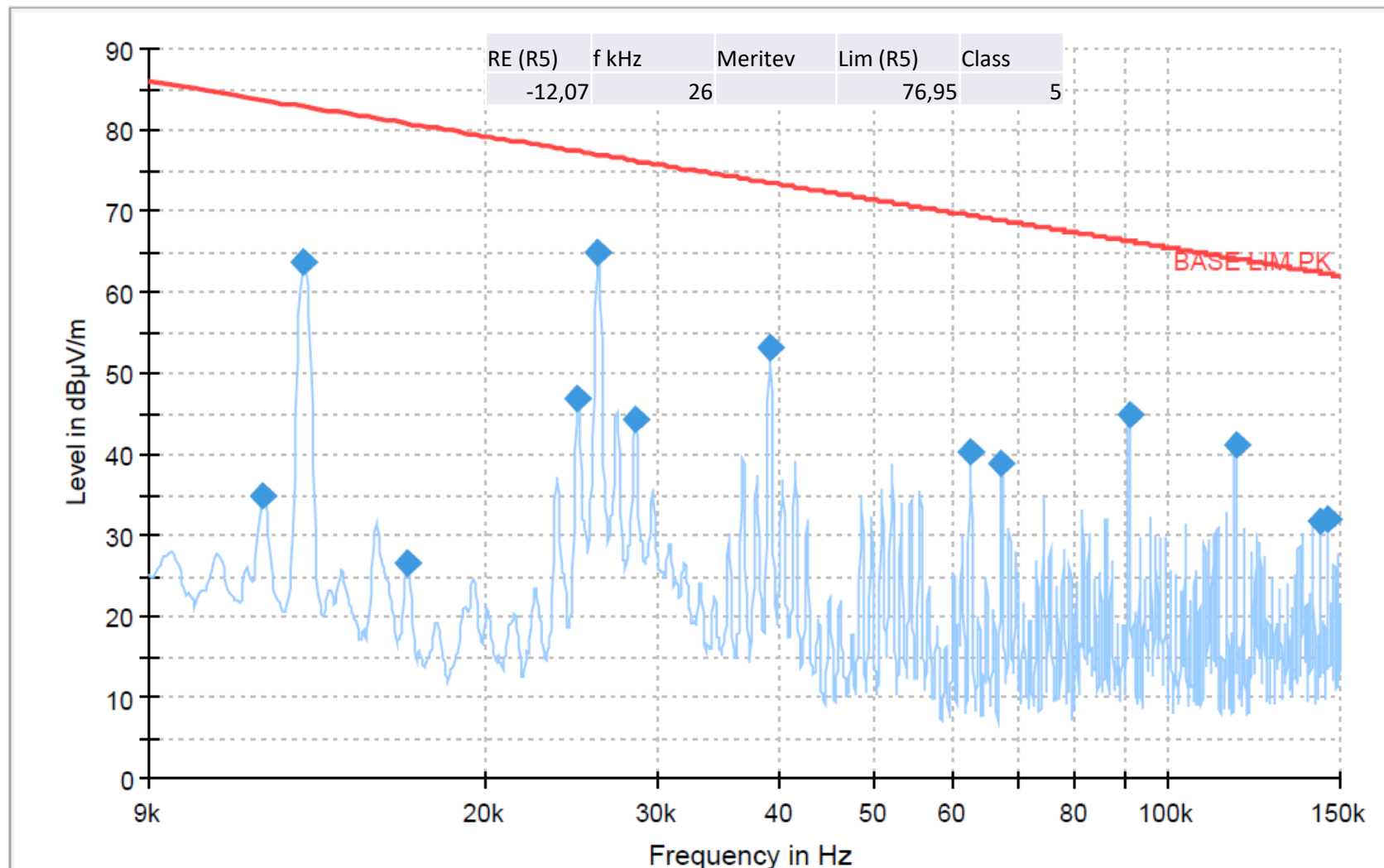

Luka Kavčič - RE

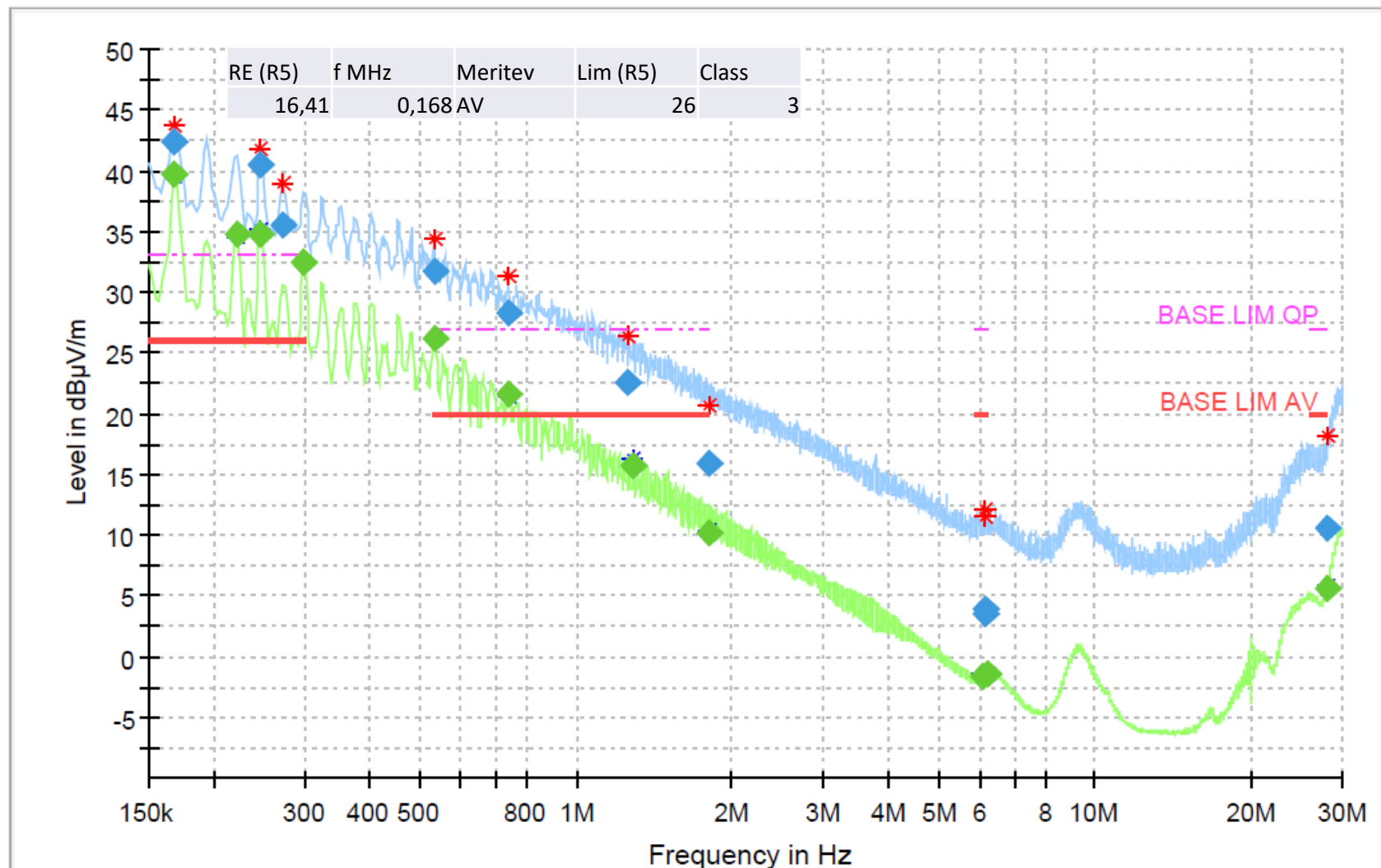

Luka Kavčič - RE

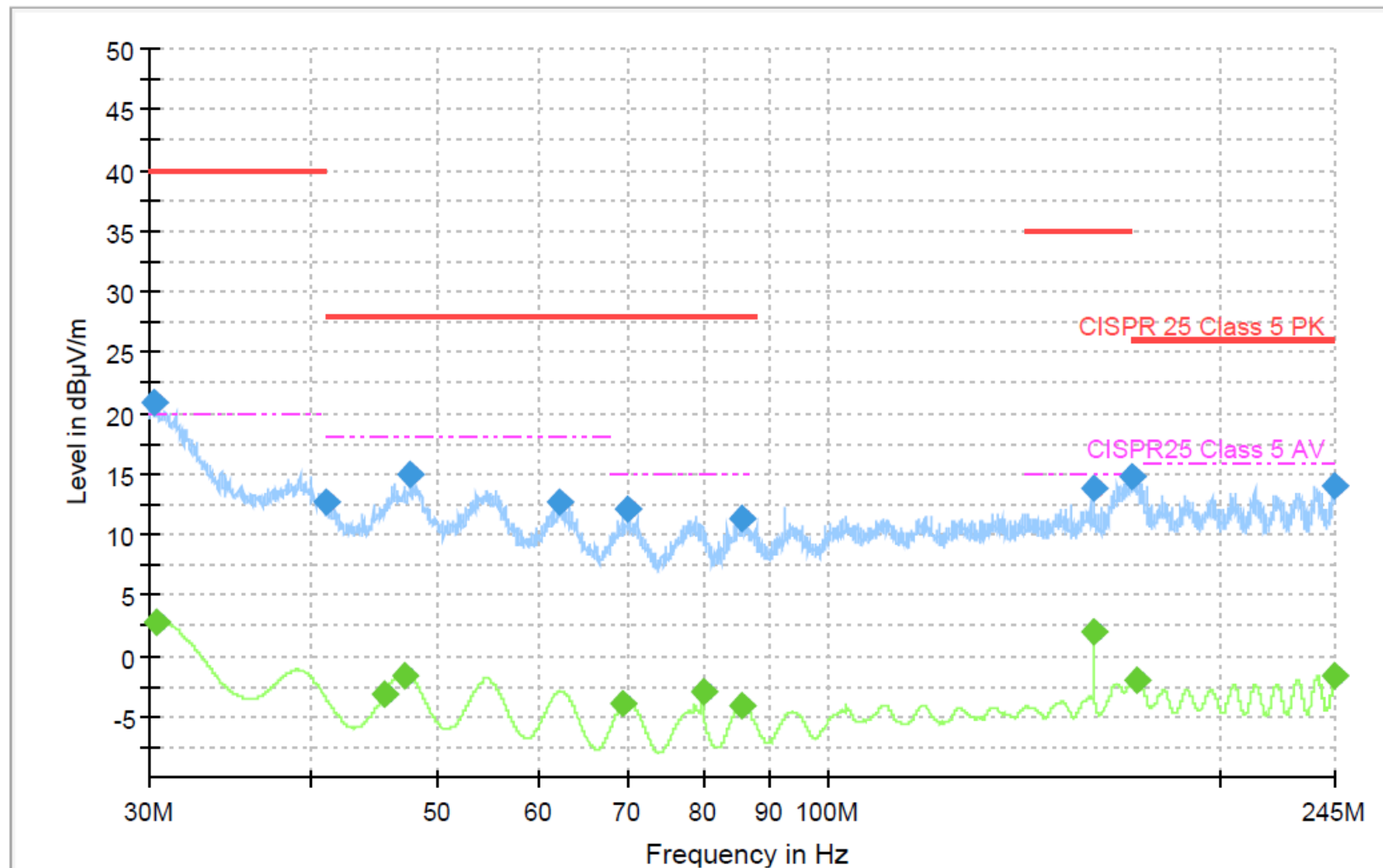

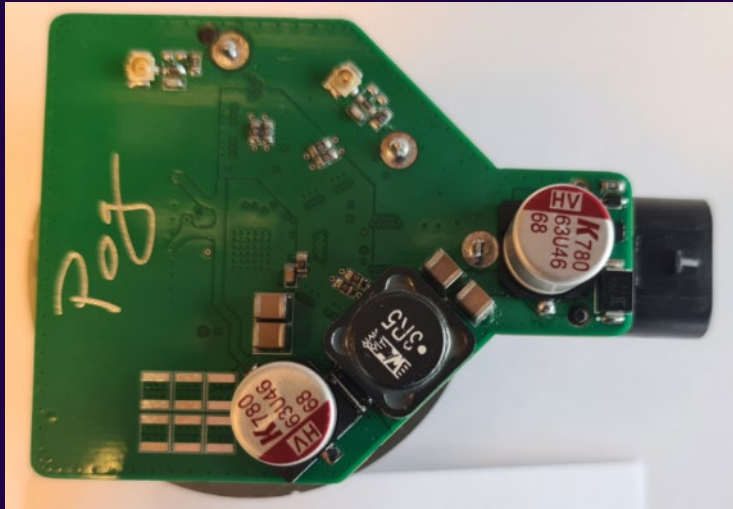

KOLEKTOR



Predstavitev

Luka Pogačnik

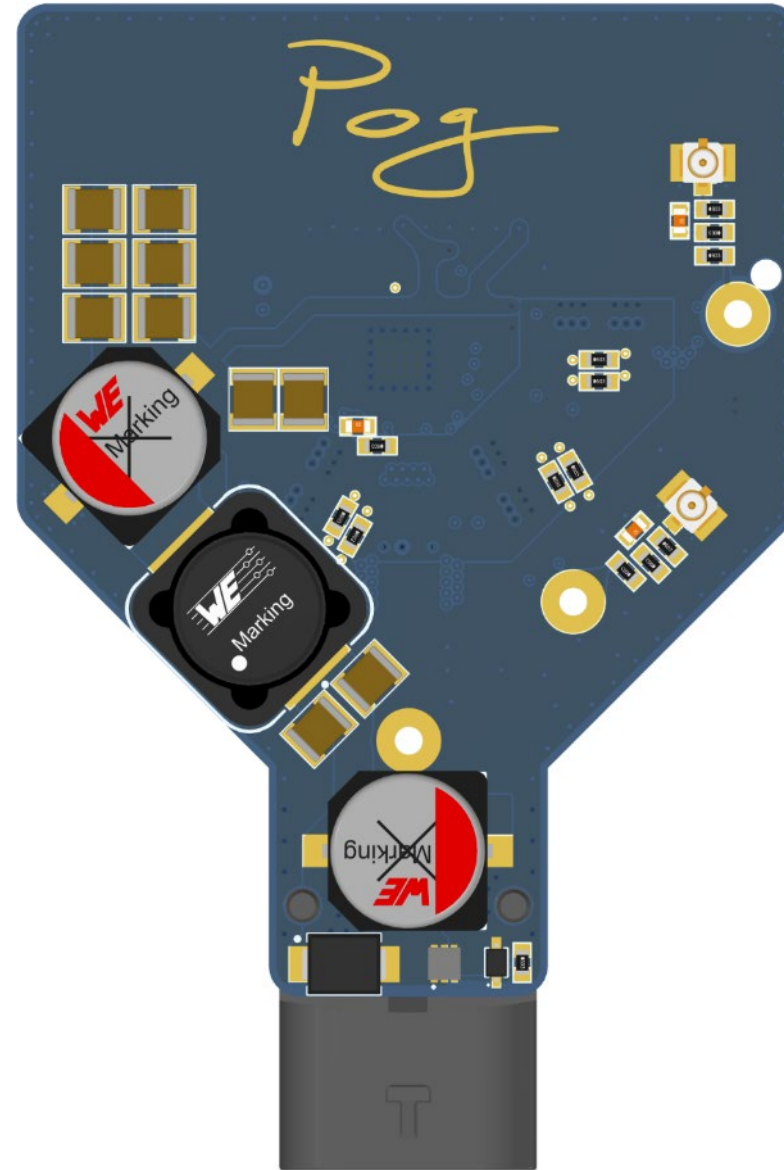
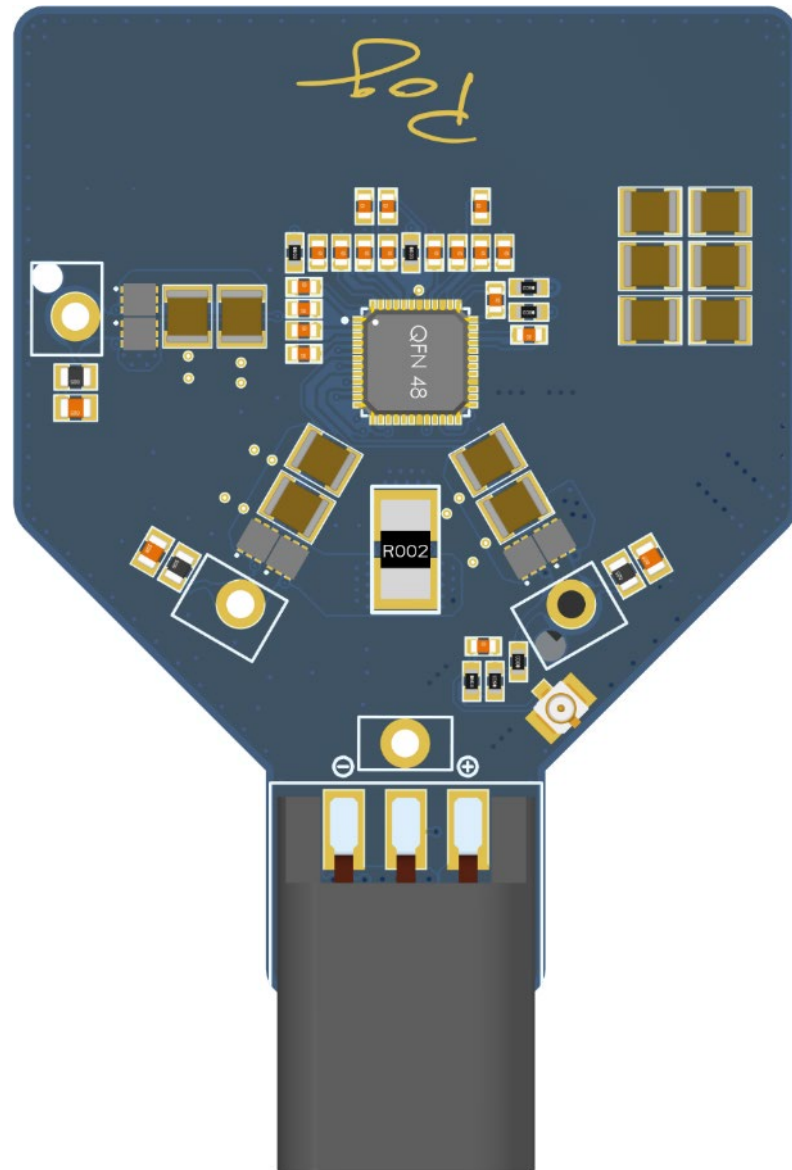

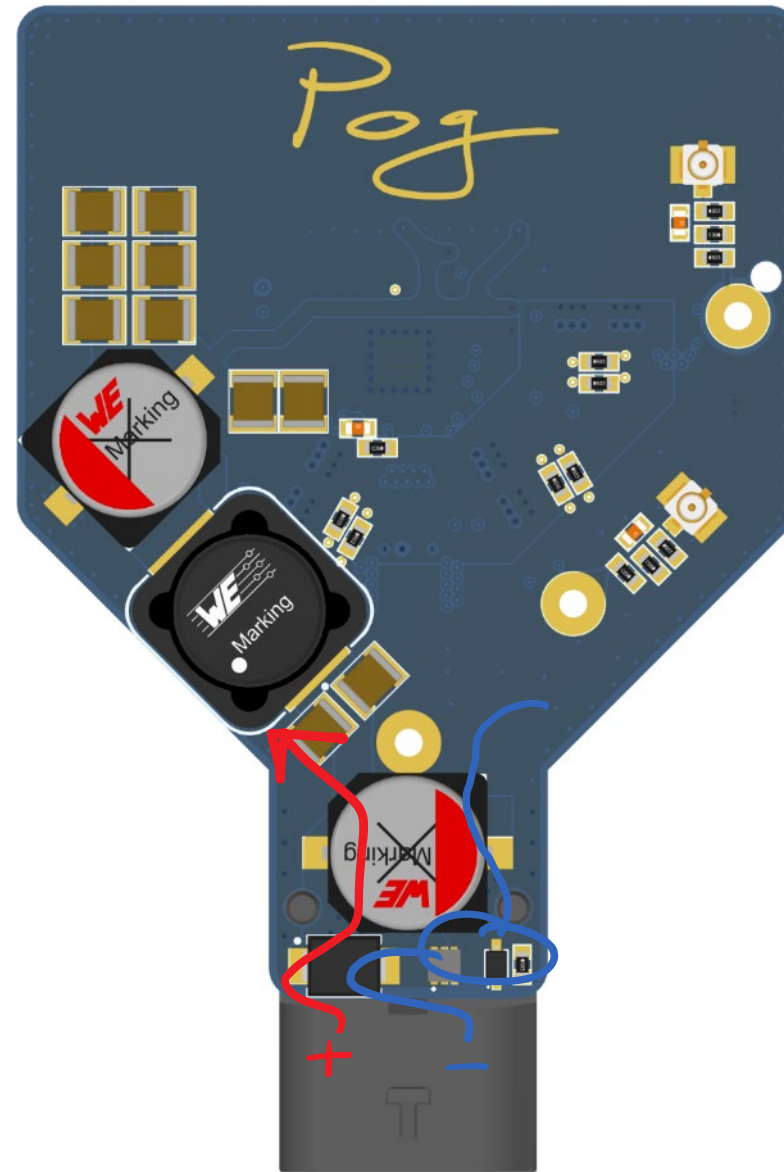
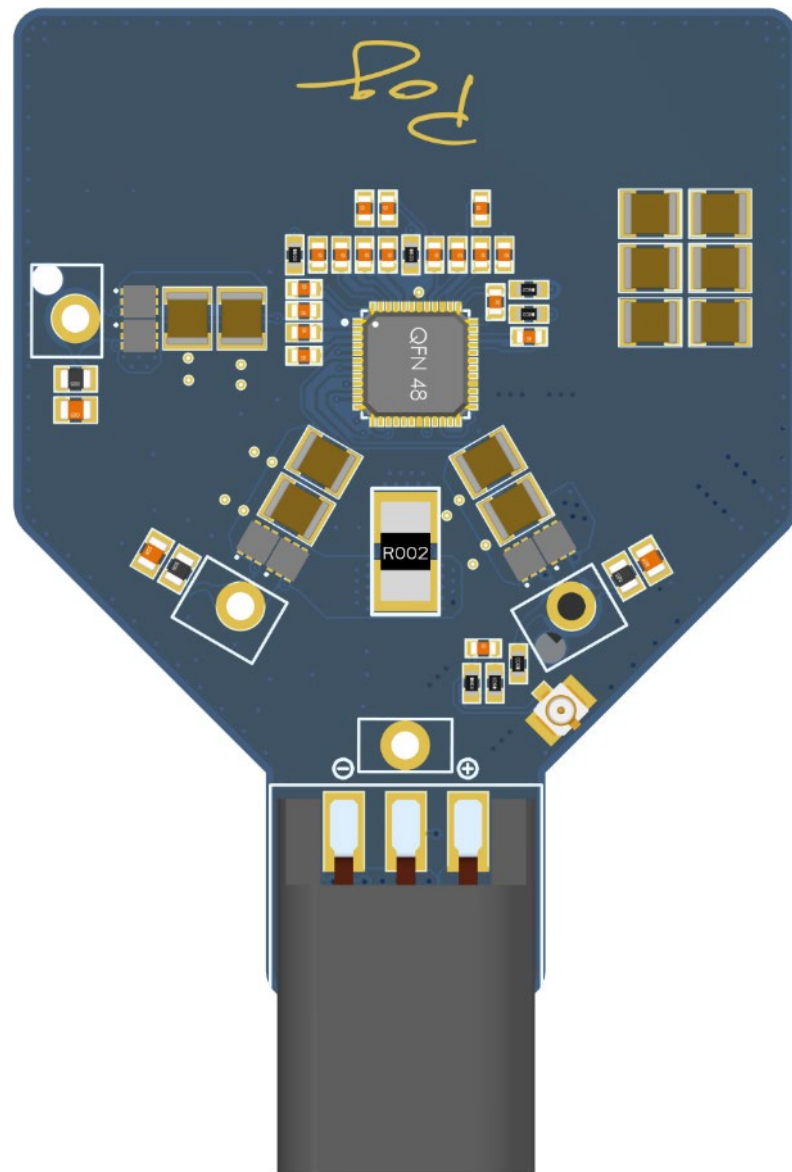

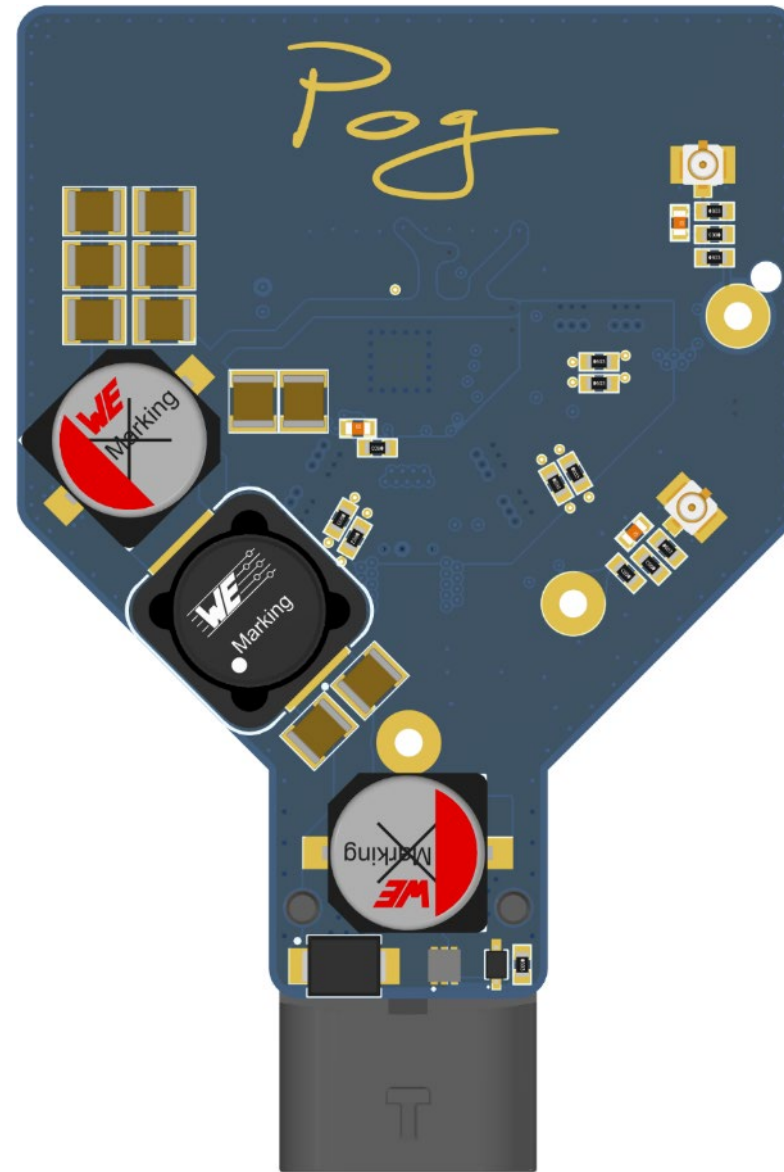
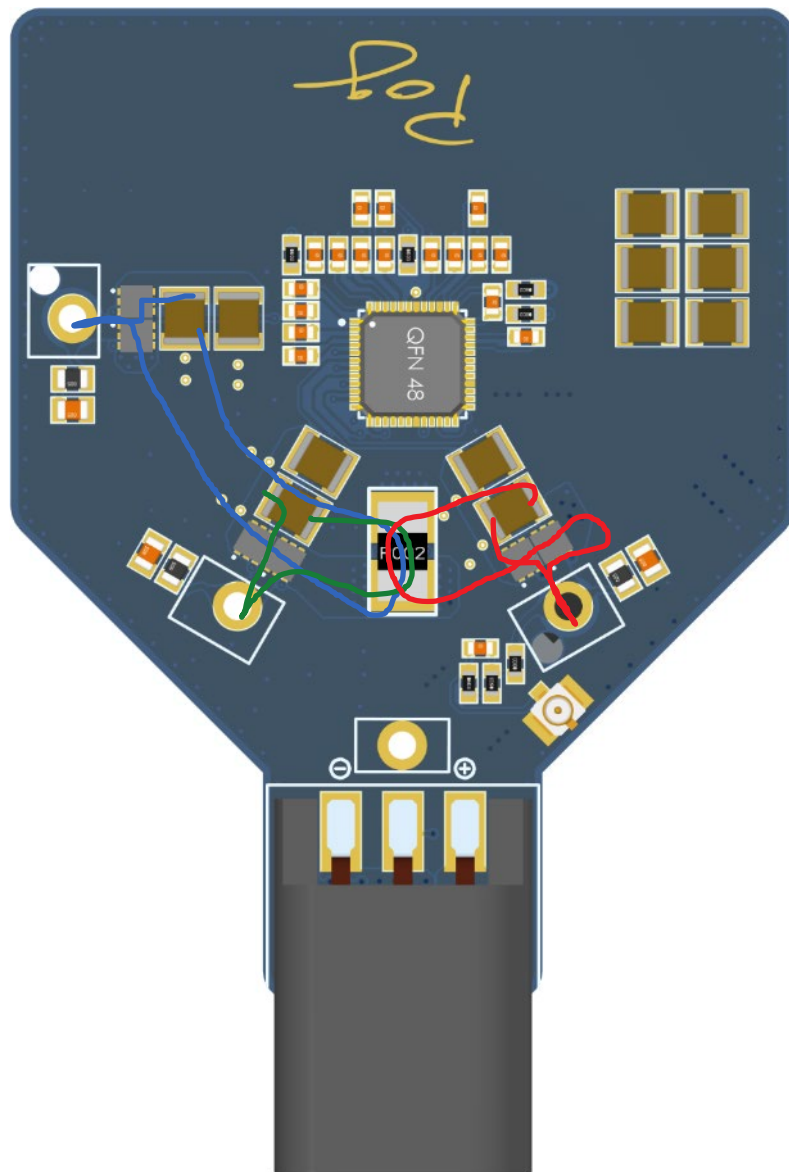

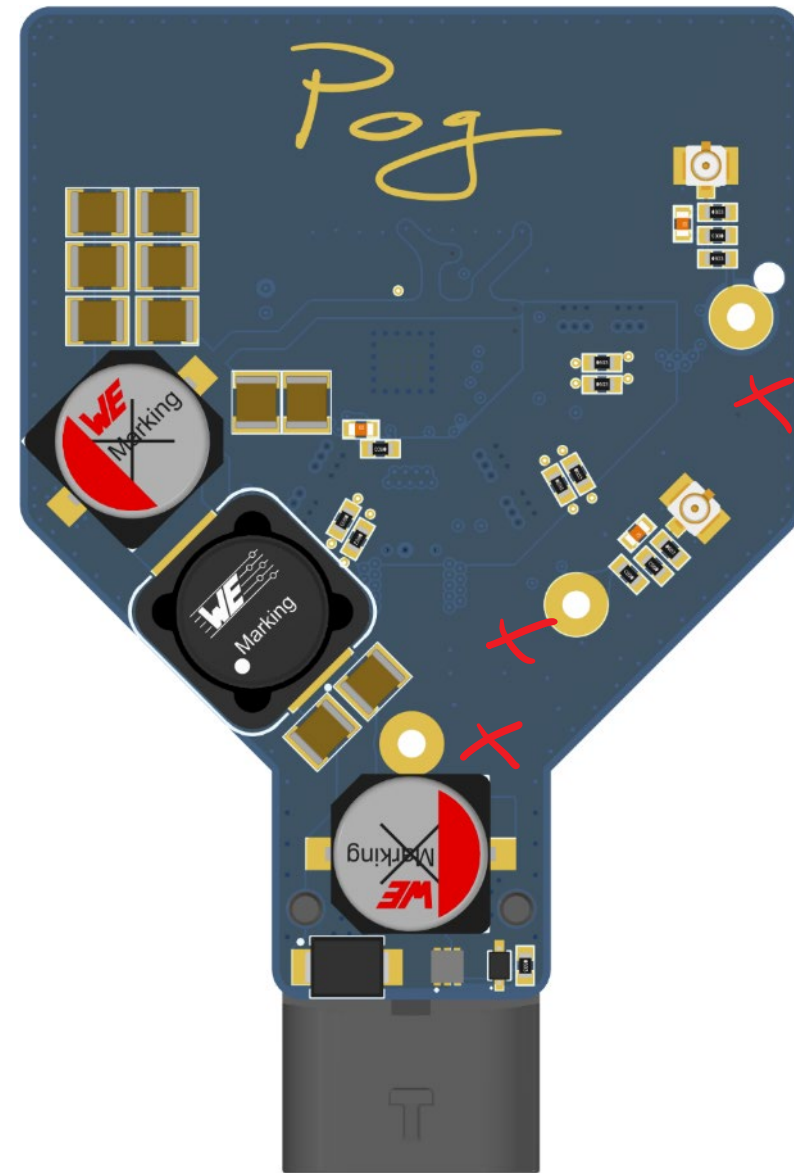
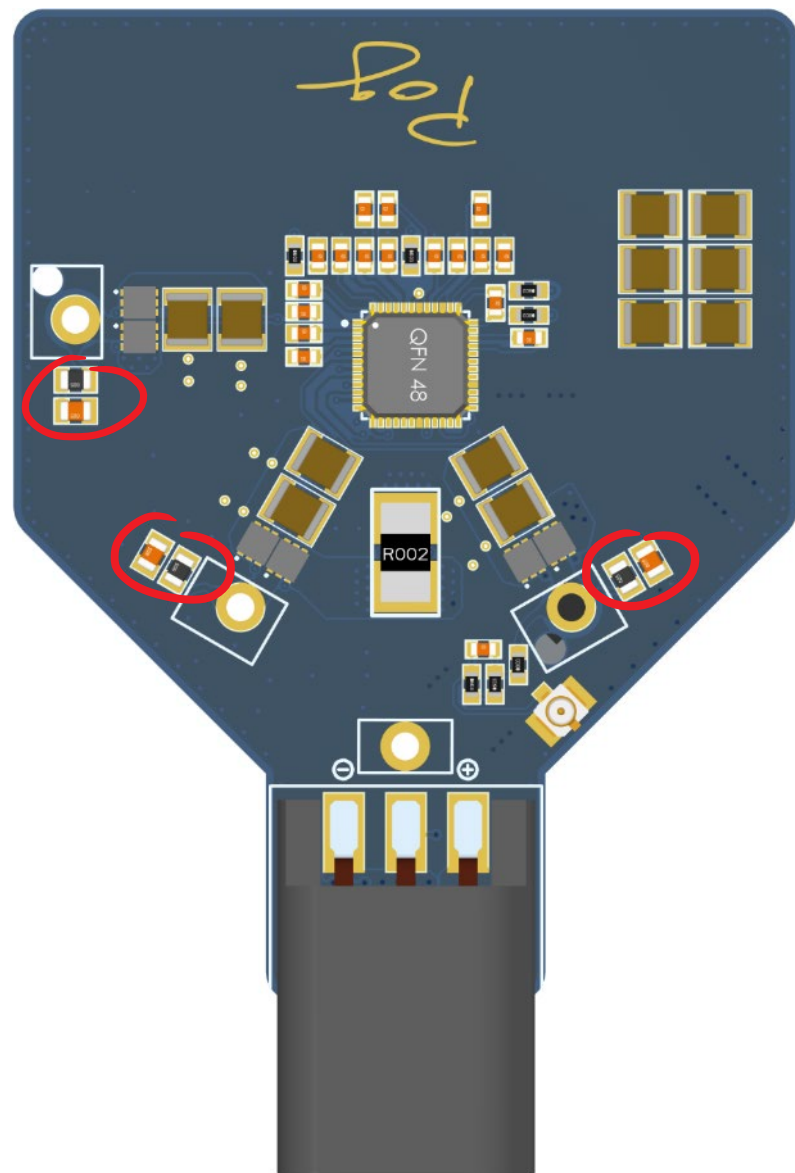

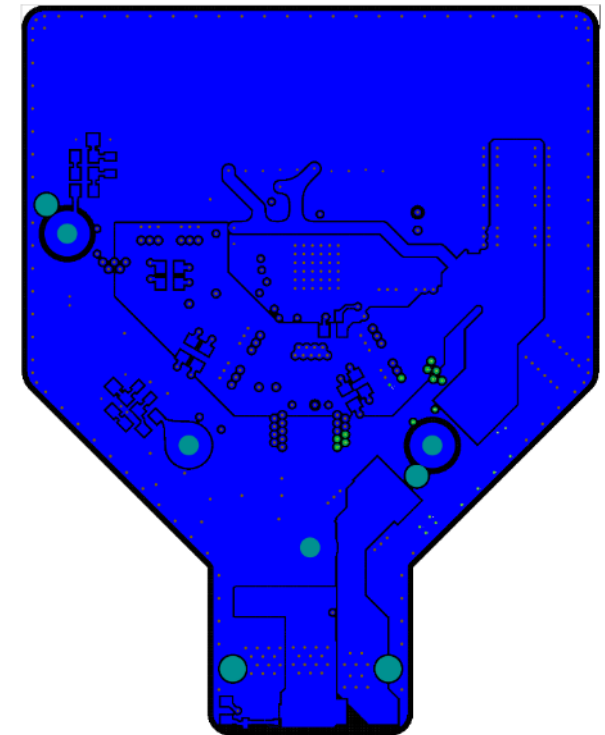
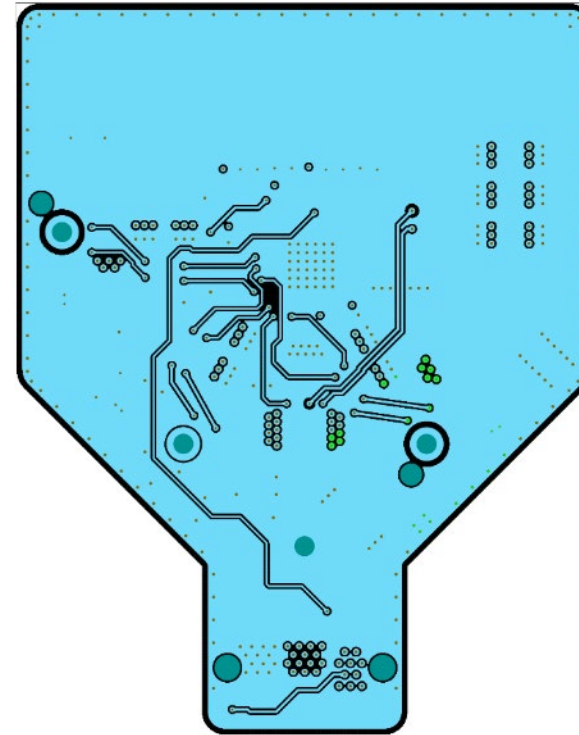
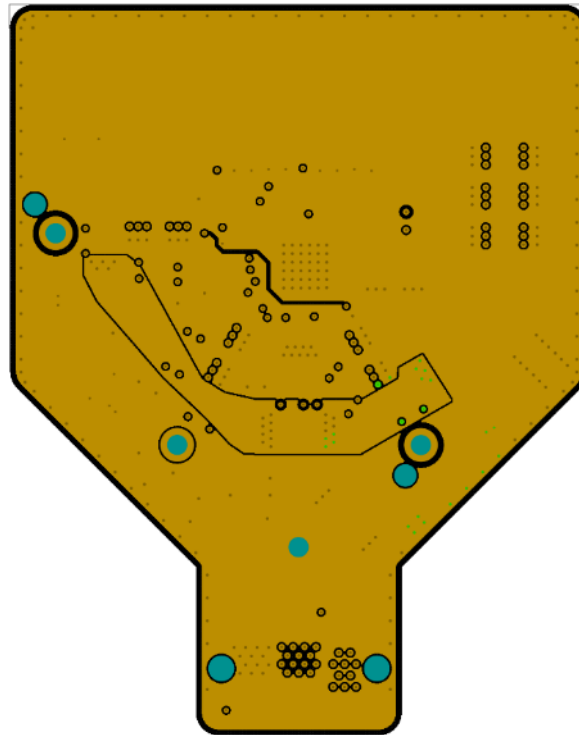
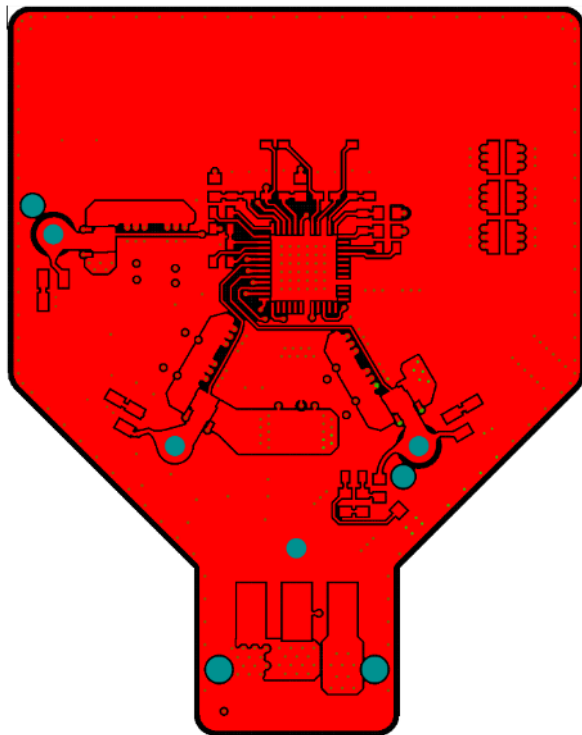

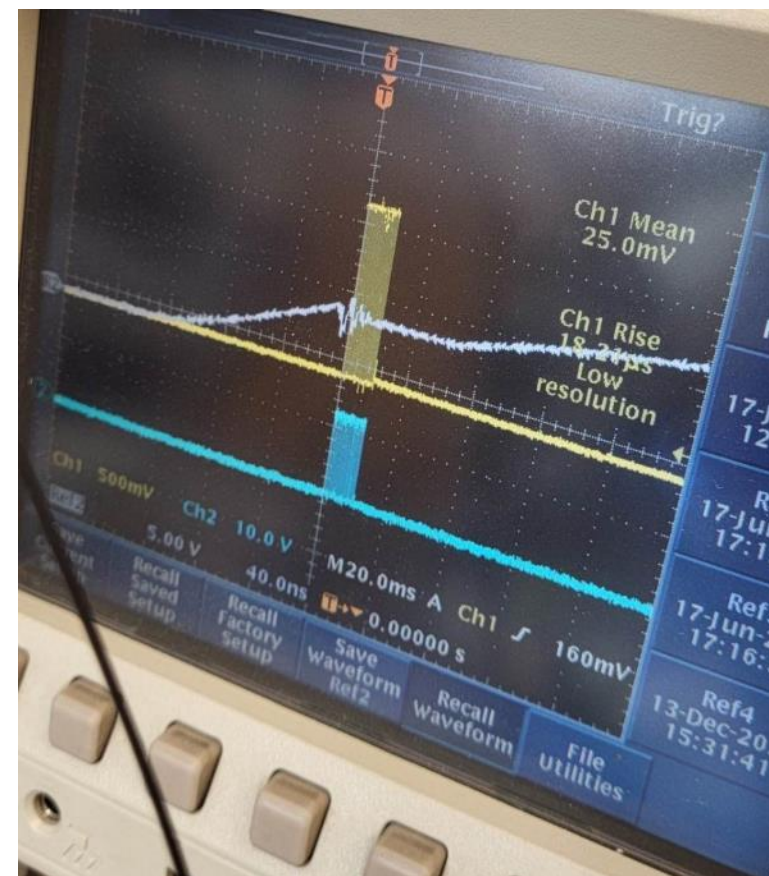

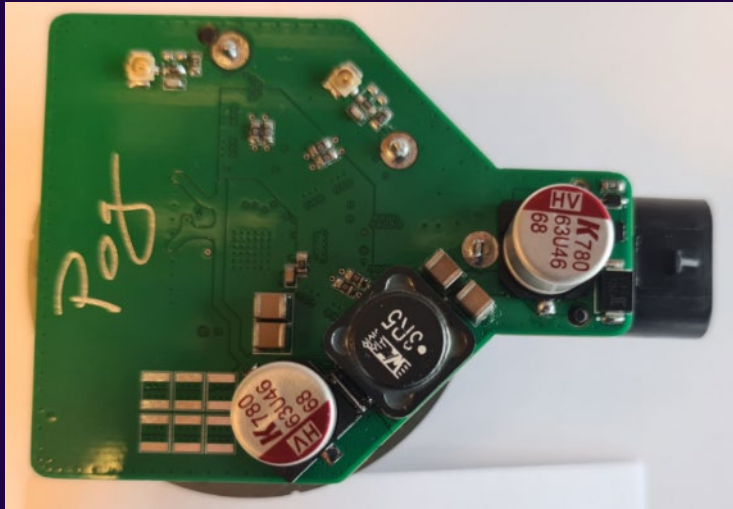

KOLEKTOR



Rezultati

Luka Pogačnik

Luka Pogačnik

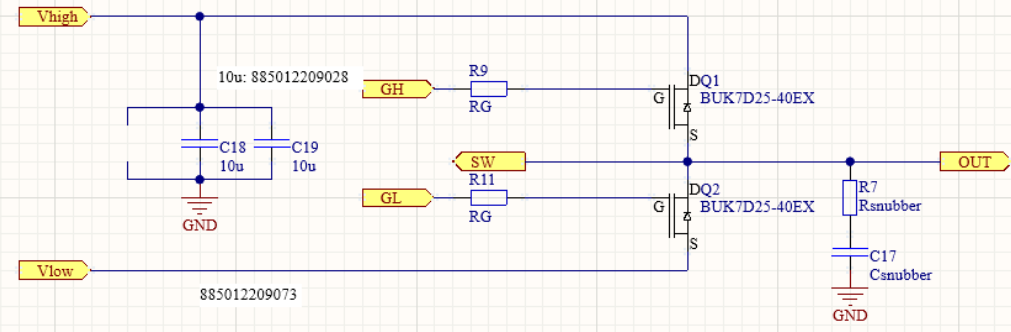
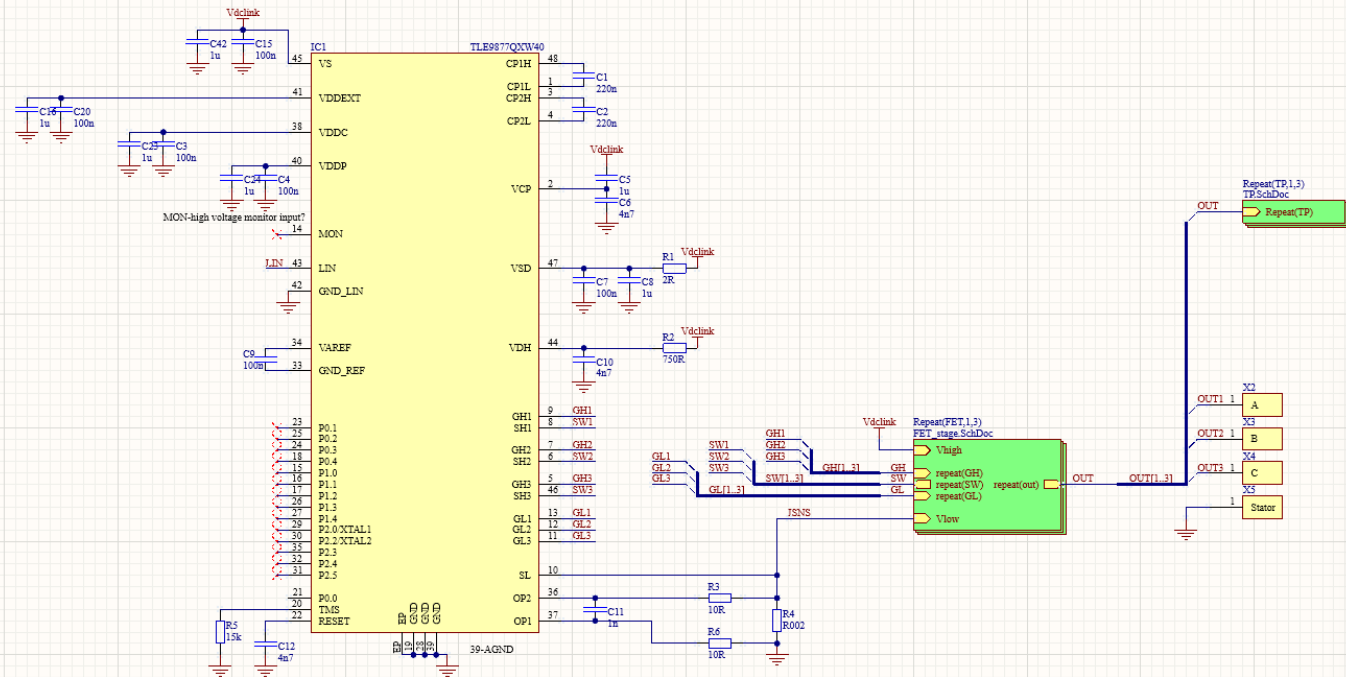
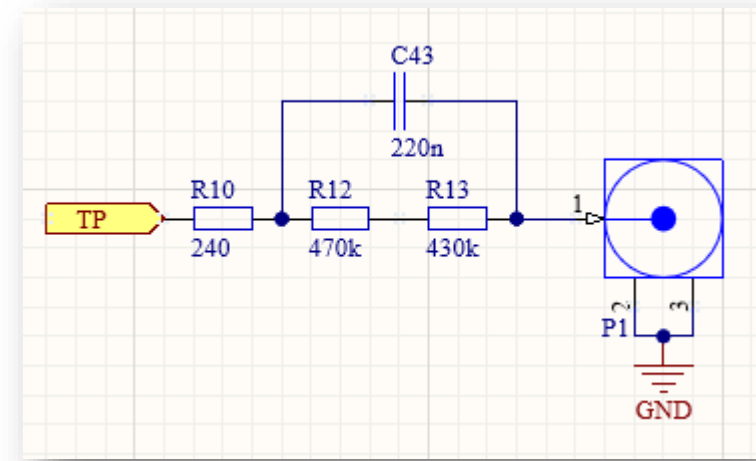
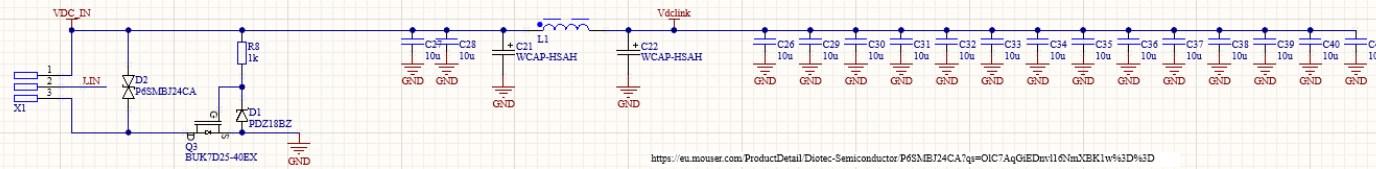

Luka Pogačnik

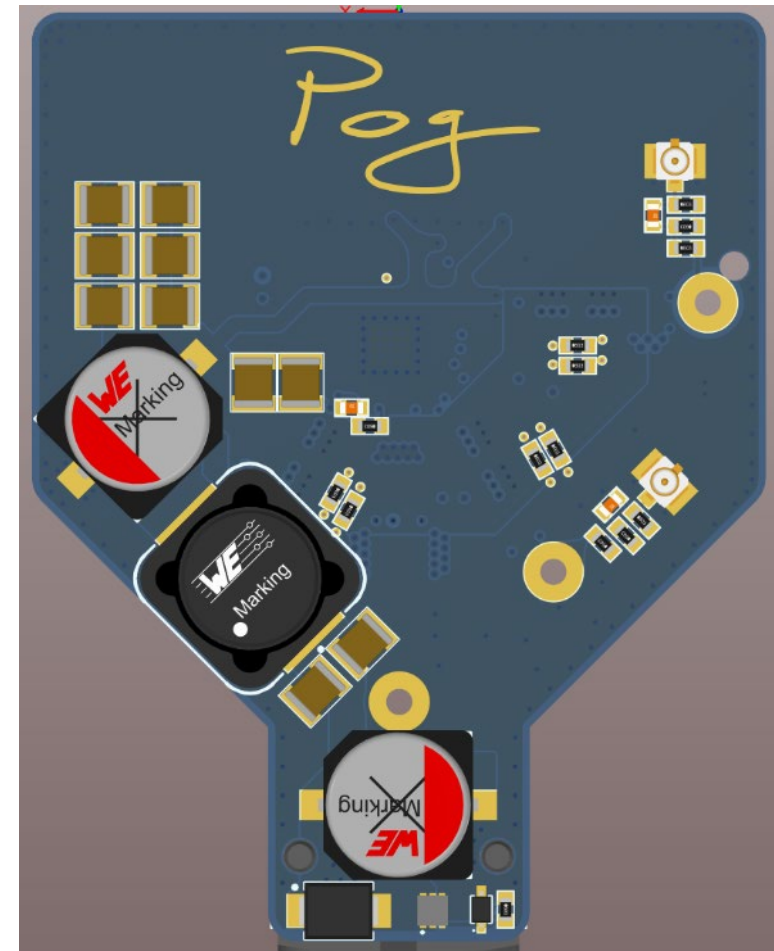
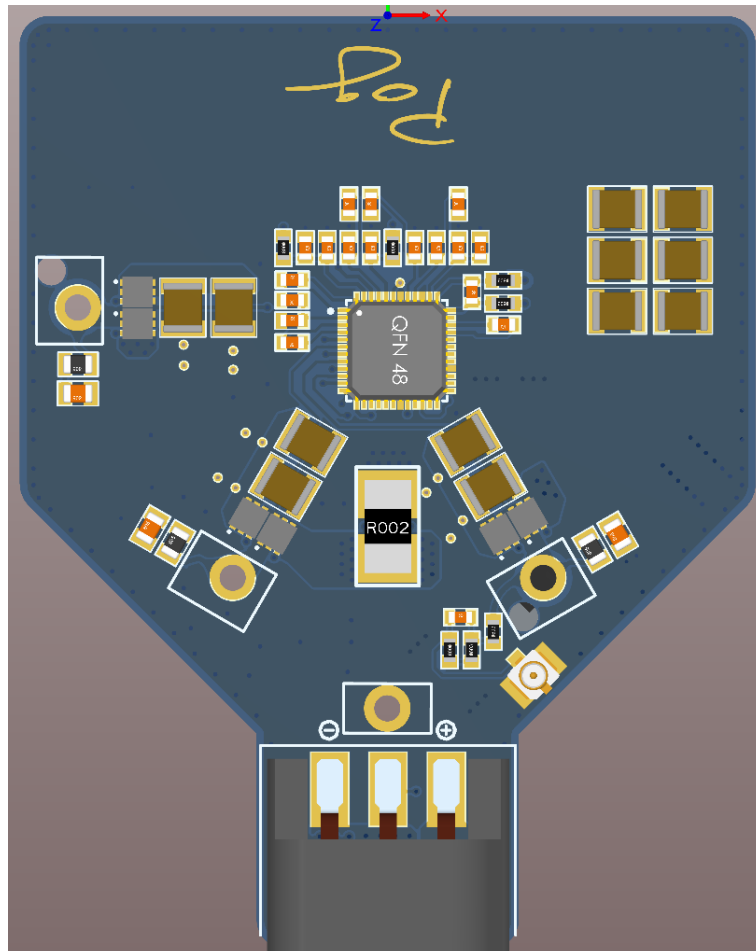

Luka Pogačnik

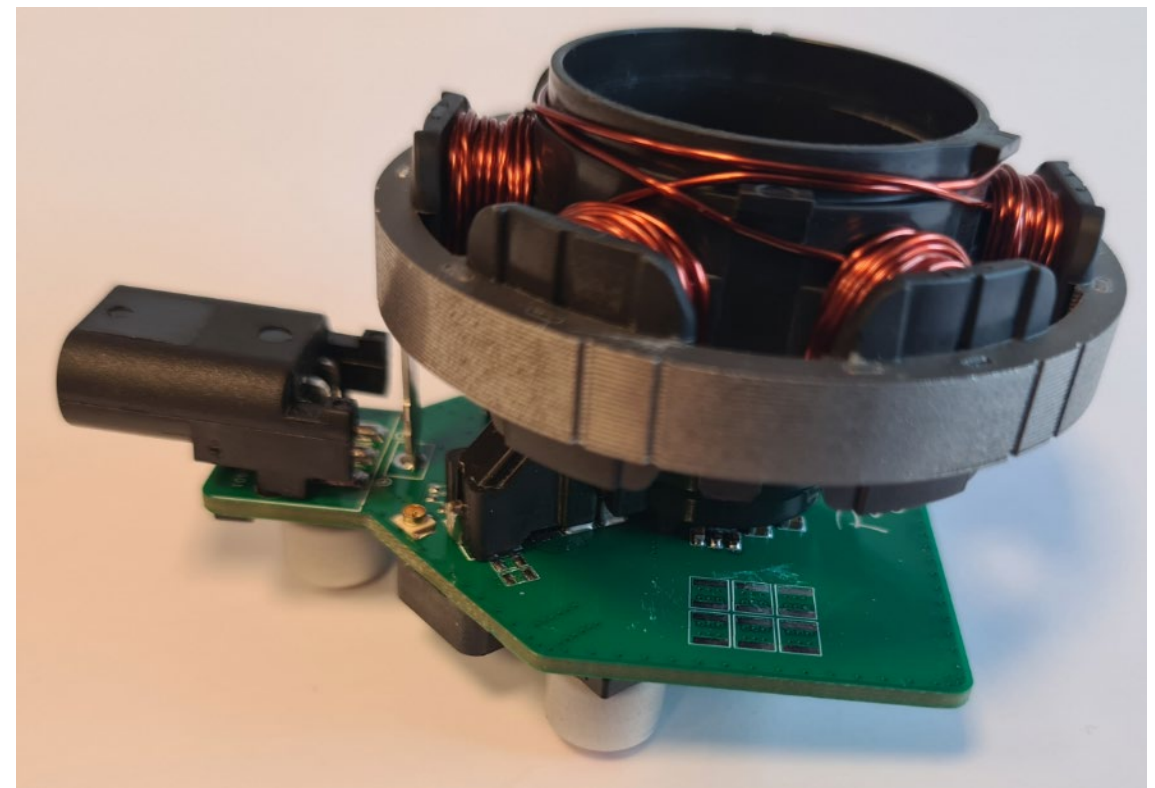
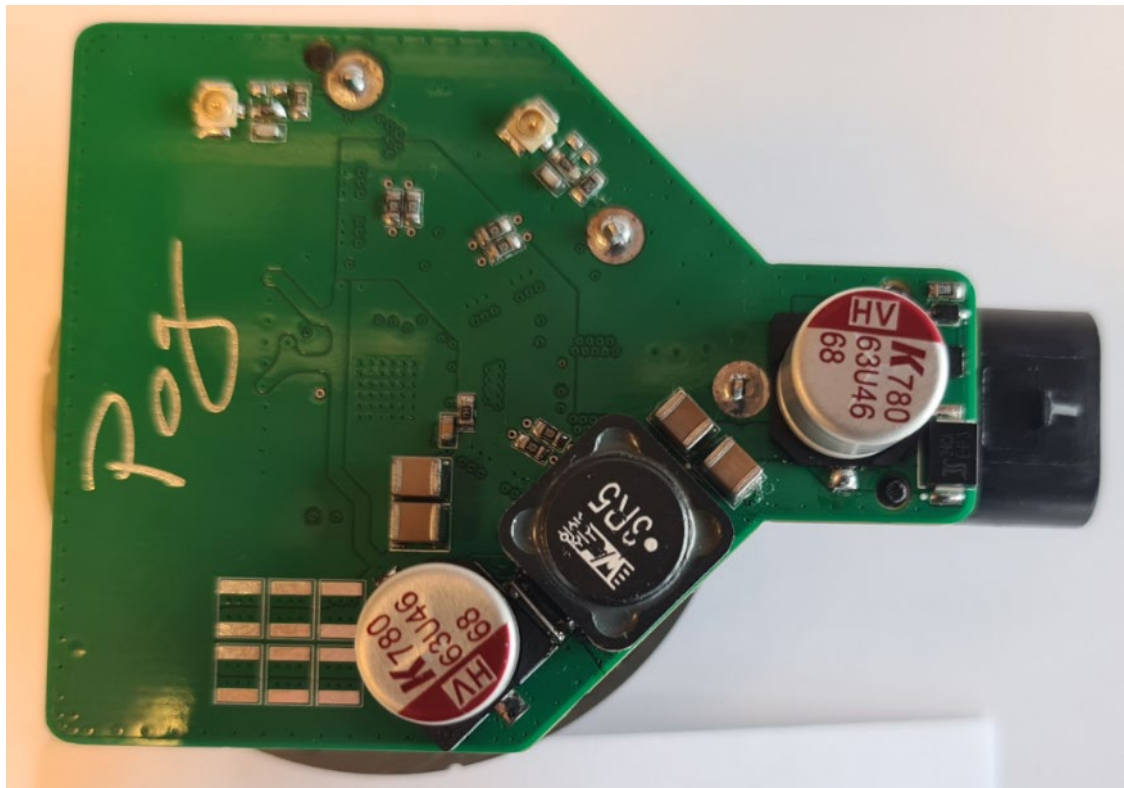

Luka Pogačnik - BOM

No.	Query	Qty	Matches	Part	Part Description	Distributor/SKU	Unit Price	Line Total	Batch Total	Notes
1	A780MN686M1JLA	2		KEMET A780MN686M1JLAS035	Aluminum Organic Polymer Capacitors 63Volt 68uF SMD 3KHz ESR=35 mOhms	DigiKey 399-A780MN686M1JLAS035... Stock: 3.000 Tape & Reel	0,3851	0,7702	770,2200	
2	PDZ18B,115	1		Nexperia PDZ18B,115	Zener Diode Single 18V 2% 20Ohm 400mW Automotive 2-Pin SOD-323 T/R	Rochester Electronics PDZ18B,115 Stock: 618.000	≈ 0,0184	≈ 0,0184	≈ 18,3799	
3	BUK7D25-40EX	7		Nexperia BUK7D25-40EX	BUK7D25 Series 40V Surface-Mounted N-channel Trench MOSFET - SOT1118	Verical BUK7D25-40EX Stock: 2.988	≈ 0,1143	≈ 0,8002	≈ 800,1821	
4	963-UMK325AB71	10		Taiyo Yuden UMK325AB7106MMHP	Multilayer Ceramic Capacitor, 10 uF, 50 V, ± 20%, X7R, 1210 [3225 Metric]	Future Electronics 8119650 Stock: 54.000 Tape & Reel	≈ 0,1660	≈ 1,6598	≈ 1.659,8175	
5	744771003	1		Würth Elektronik 744771003	Ind Power Choke Shielded Wirewound 3.5uH 20% 1KHz Ferrite 9.25A T/R	DigiKey 732-1205-2-ND Stock: 0 Tape & Reel	0,716 1,0895	1,0895	1.089,5400	

Tekmovalec	cena tranzistorjev	Cena kondenzatorjev	Cena dušilk	Cena diod	Skupaj
Luka Pogačnik	0,80 €	2,43 €	0,72 €	0,02 €	3,96 €

Tekmovalec	kvalifikacija	temp. območje	ostale zahteve	Cena komponent	Točke
Luka Pogačnik	3	3	3	3,96 €	-10,8

Luka Pogačnik - delovanje

- Odpoved kosa pri zagonu na 15V
- Izkoristek N/A
- Prenihaj N/A
- Padeč napetosti N/A
- Tok nasprotne polaritete 0,1 mA

Tekmovalec	Osnovna	Izkoristek	Polariteta	Padeč r	Prenihaj	Točke
Luka Pogačnik	10	0	5	0	0	15

Luka Pogačnik - CE

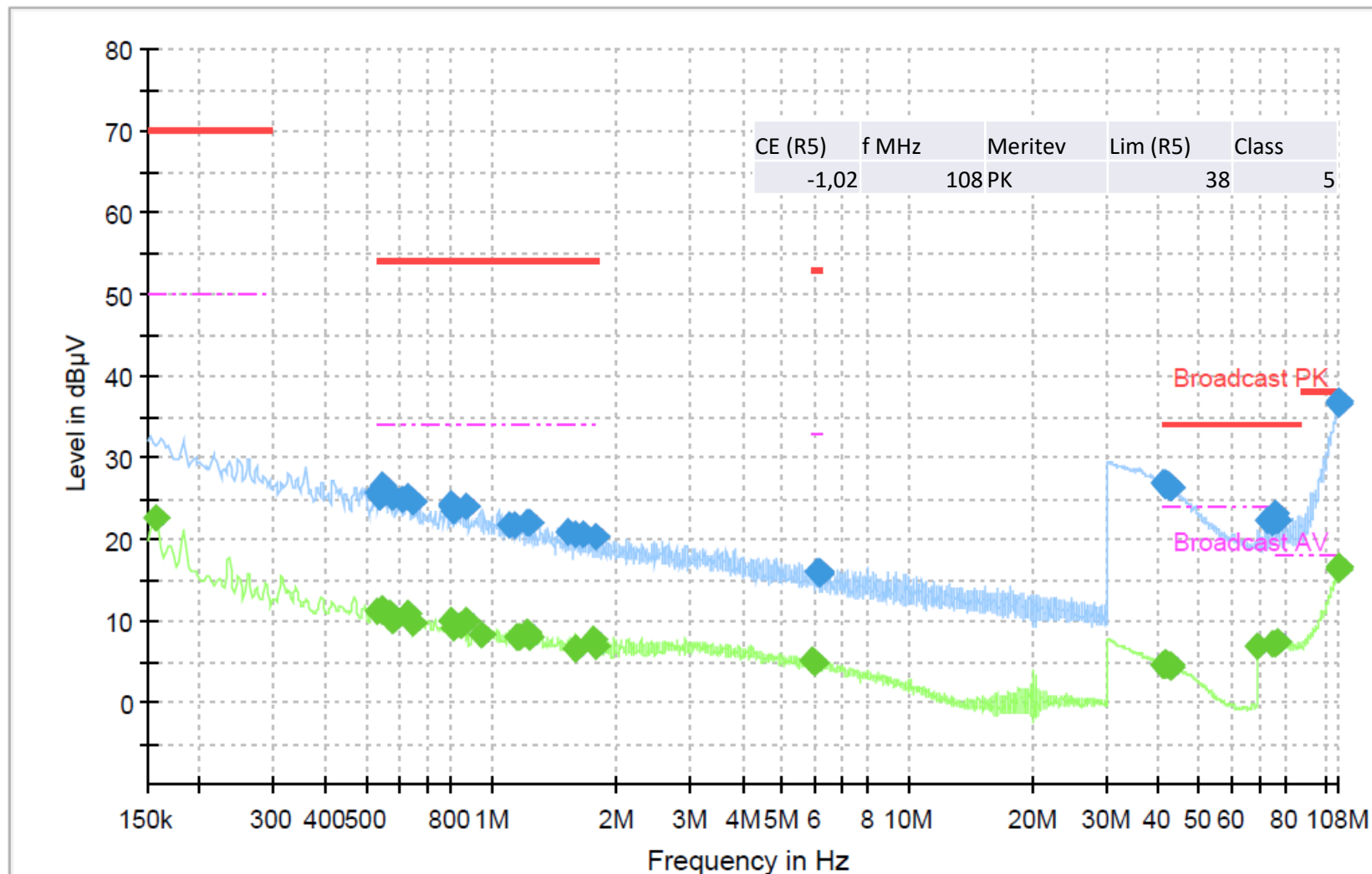

Luka Pogačnik – VW+RE

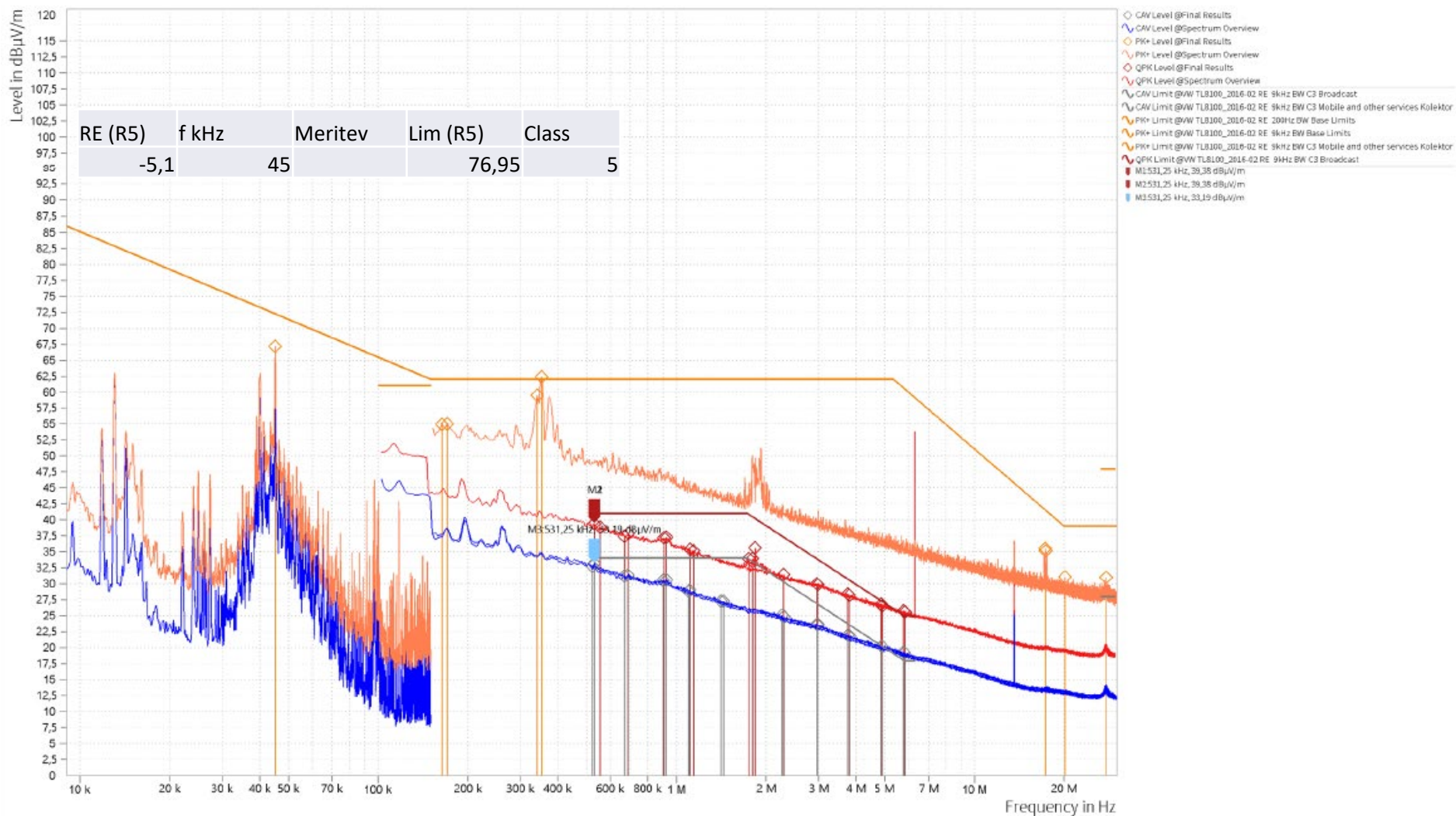

Luka Pogačnik - RE

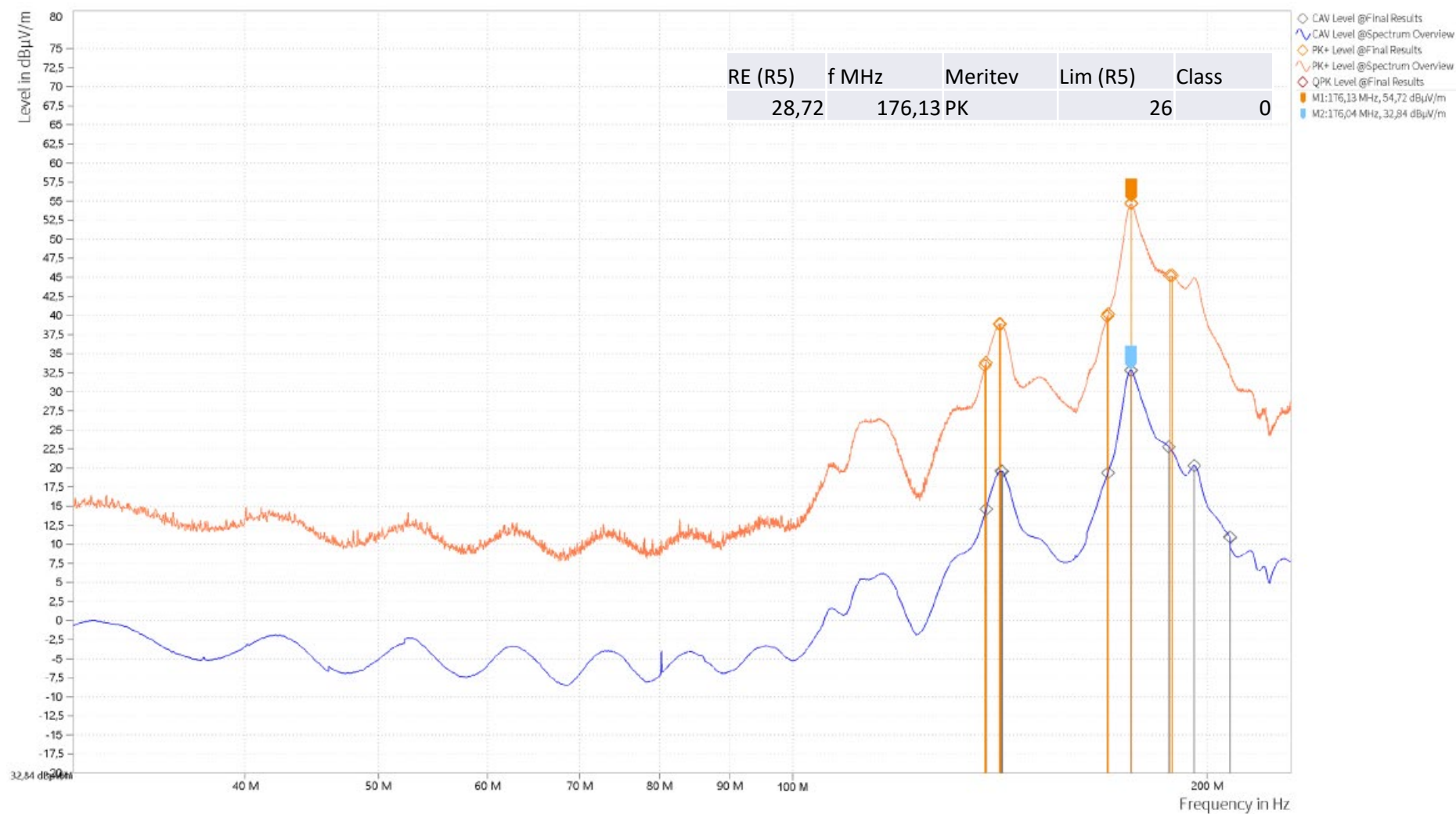

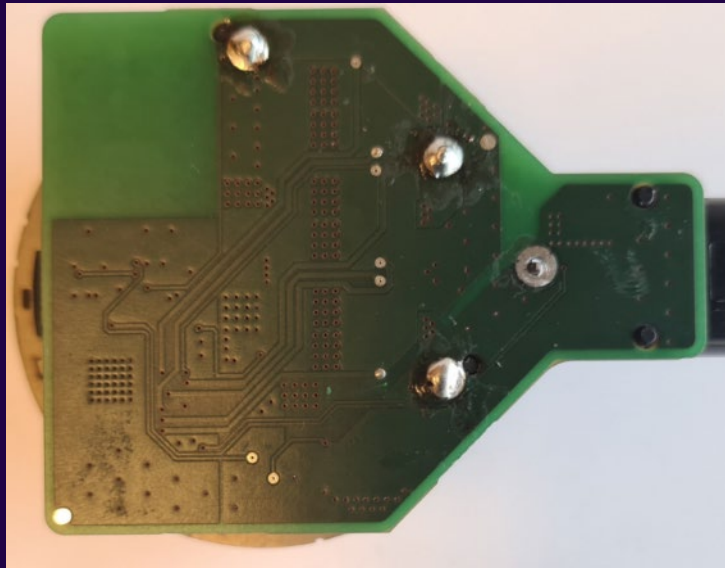

KOLEKTOR



Predstavitev

Maj Pavlin

Shema

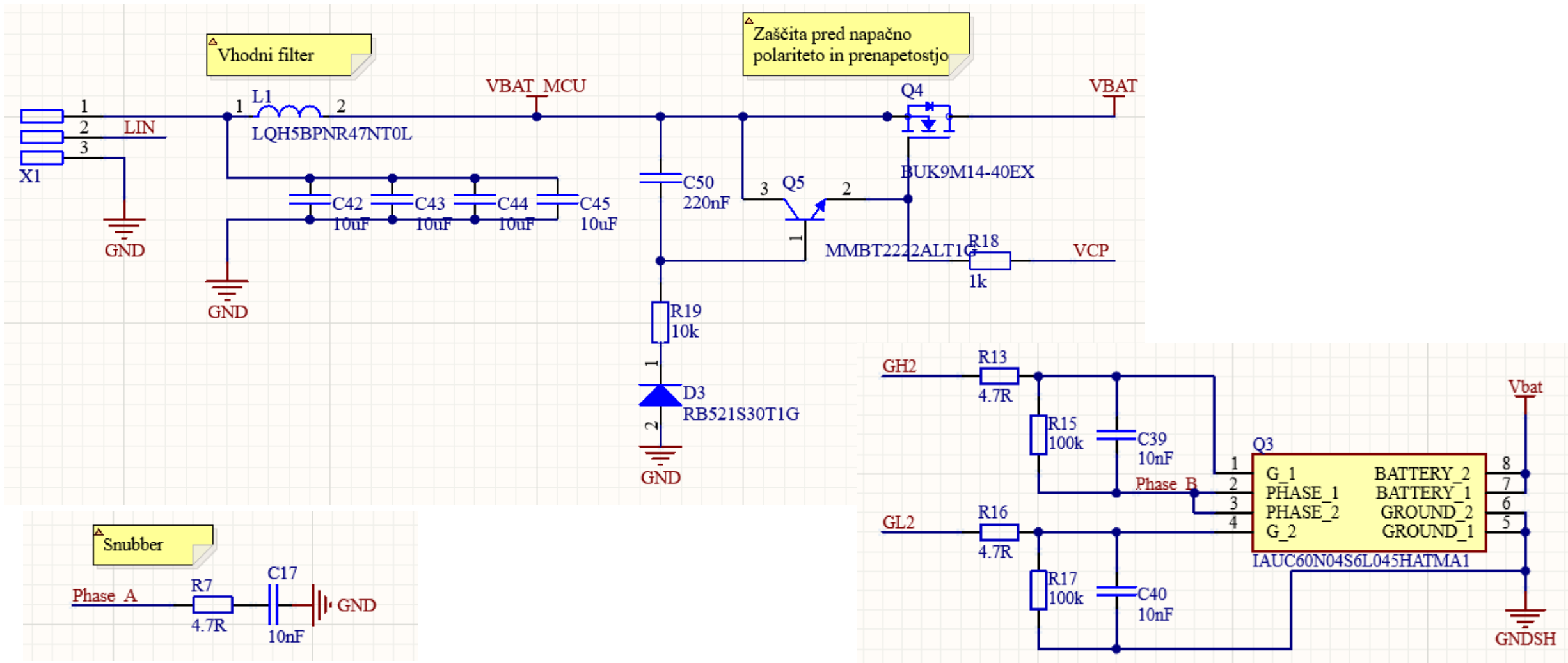

Izračuni, simulacije

- Infineon reference design
- REDEXPERT®

Načrt tiskanega vezja

LAYER STACKUP

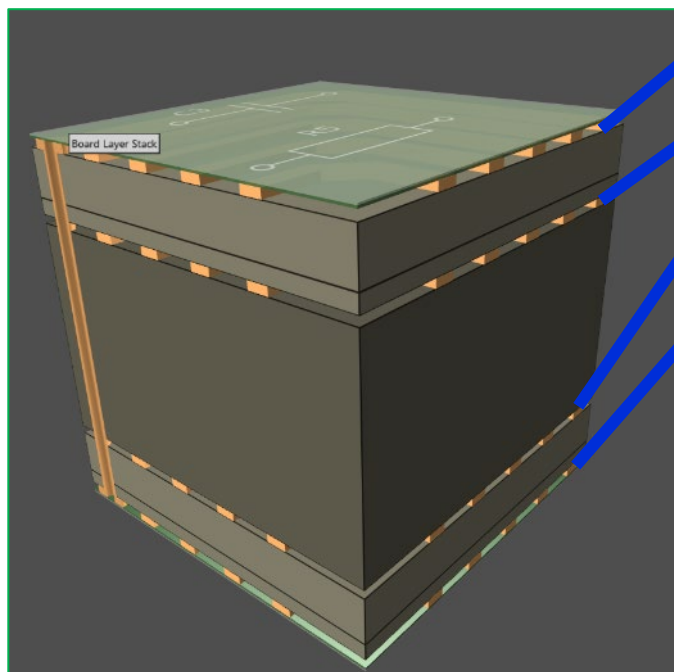

1. SIGNAL
2. POWER
3. GND
4. SIGNAL

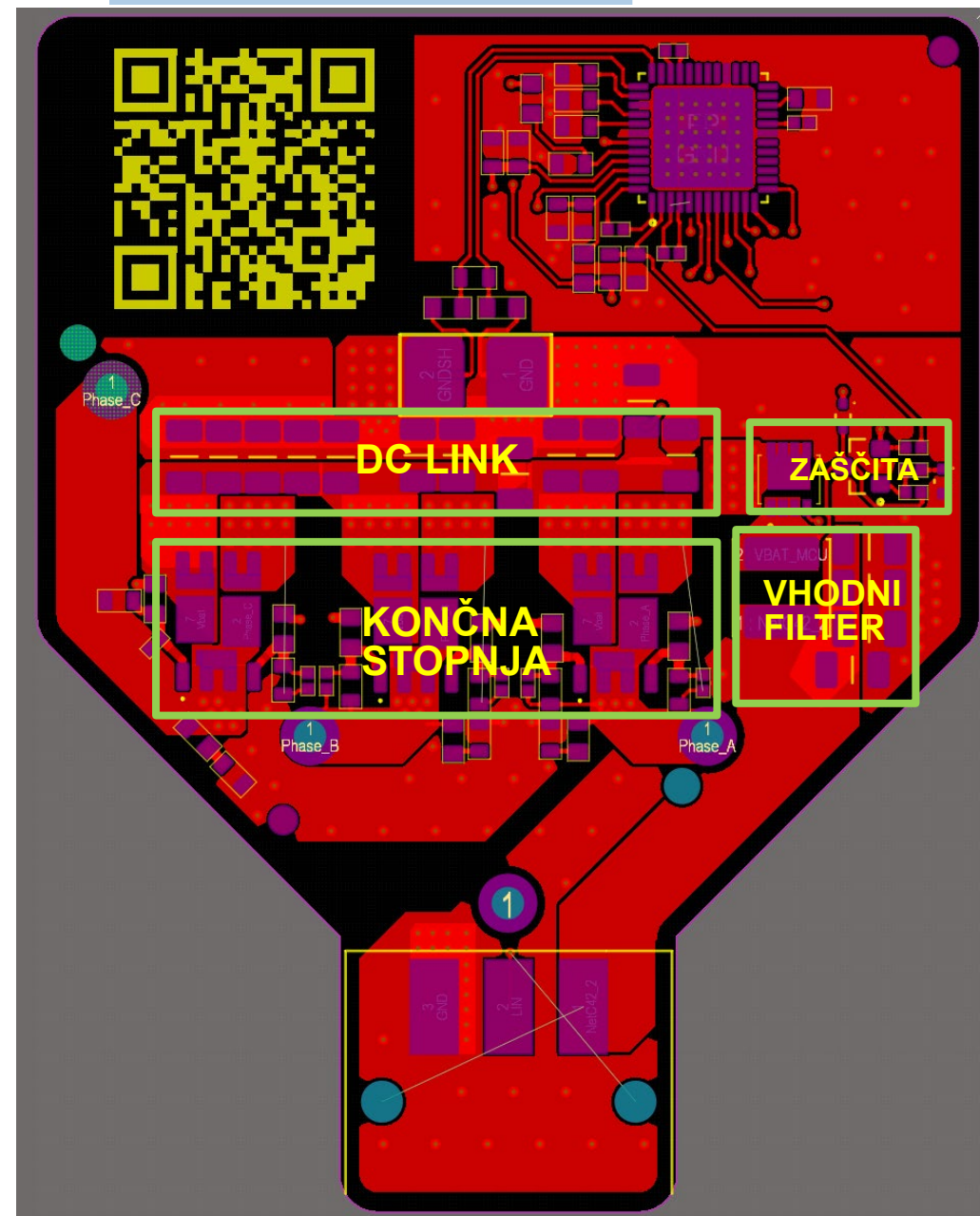

Preliminarne meritve

$R_{gate} = 10 \text{ Ohm}$

DSO-X 2024A, MY52101226: Sun Jun 11 13:33:45 2023



$R_{gate} = 4,7 \text{ Ohm}$
 $C_{gate} = 10 \text{ nF}$



DSO-X 2024A, MY52101226: Wed Jun 14 21:52:21 2023

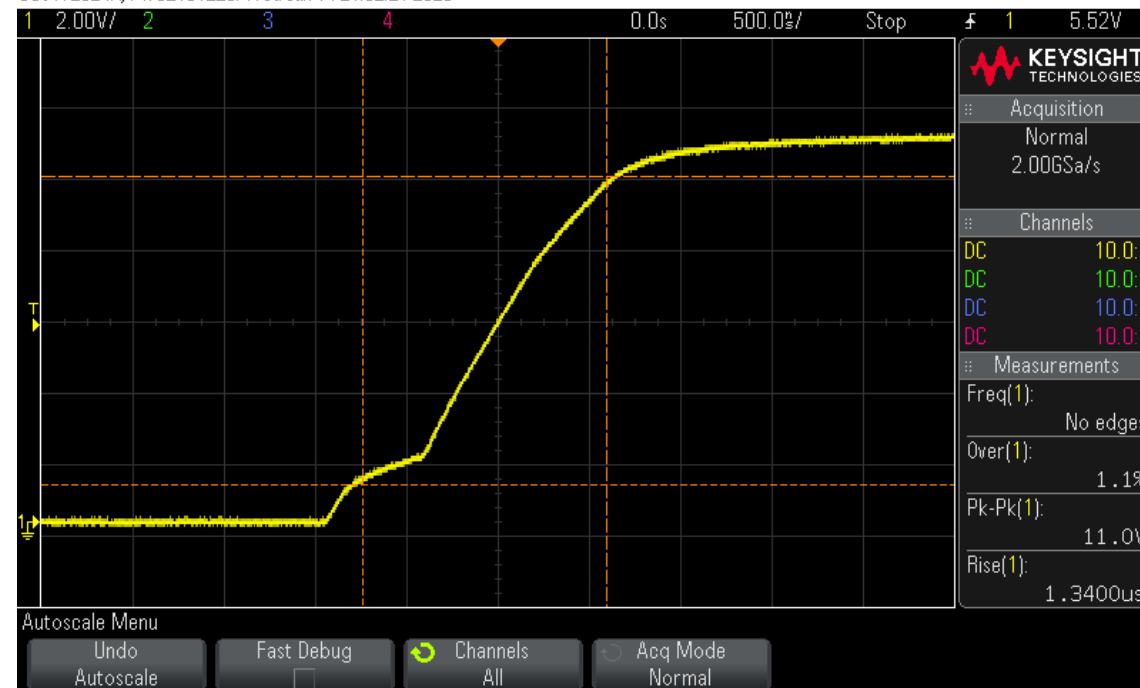

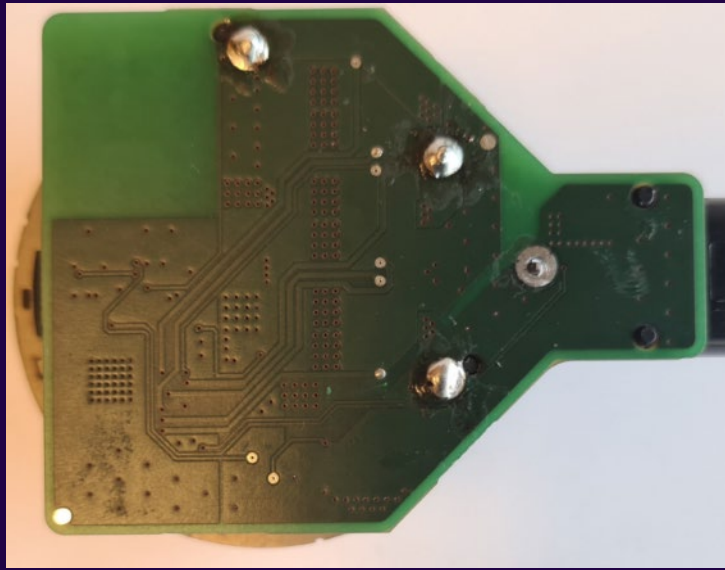

KOLEKTOR



Rezultati

Maj Pavlin

Maj Pavlin

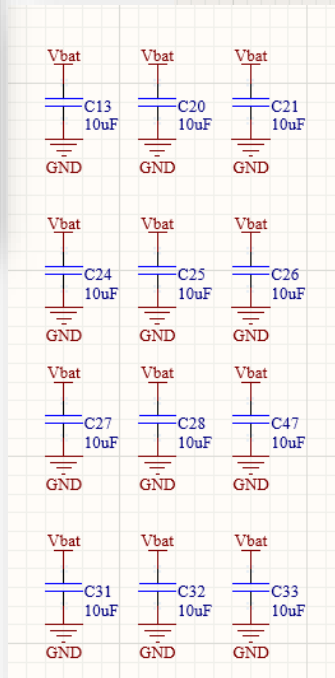
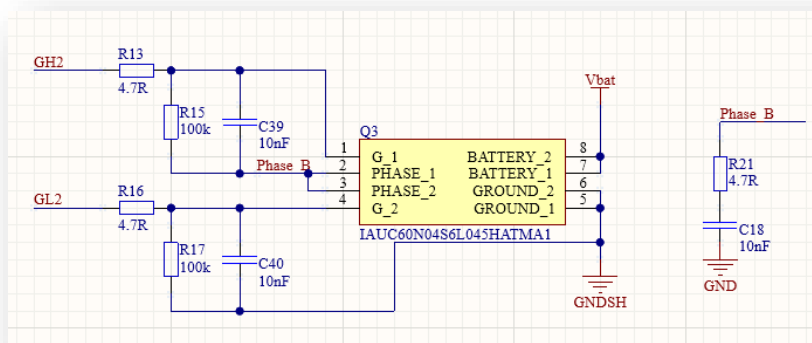
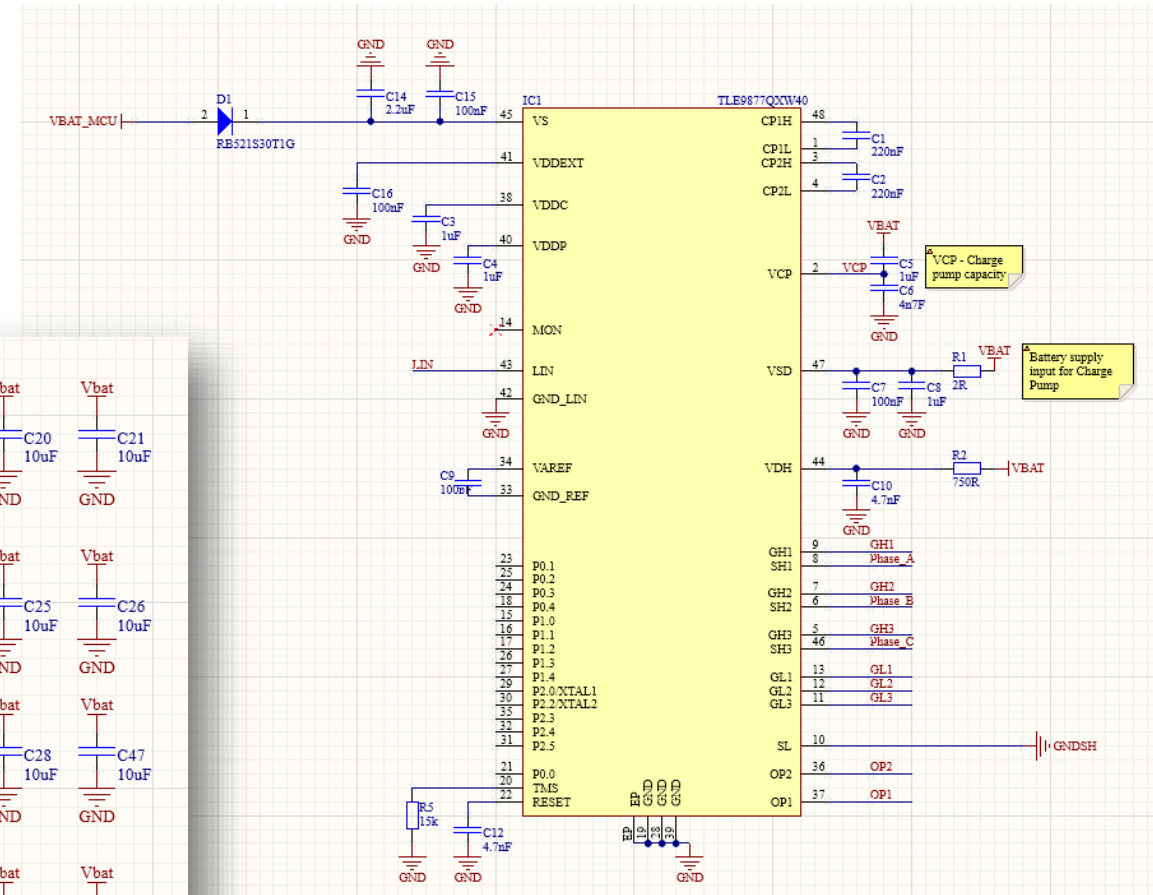
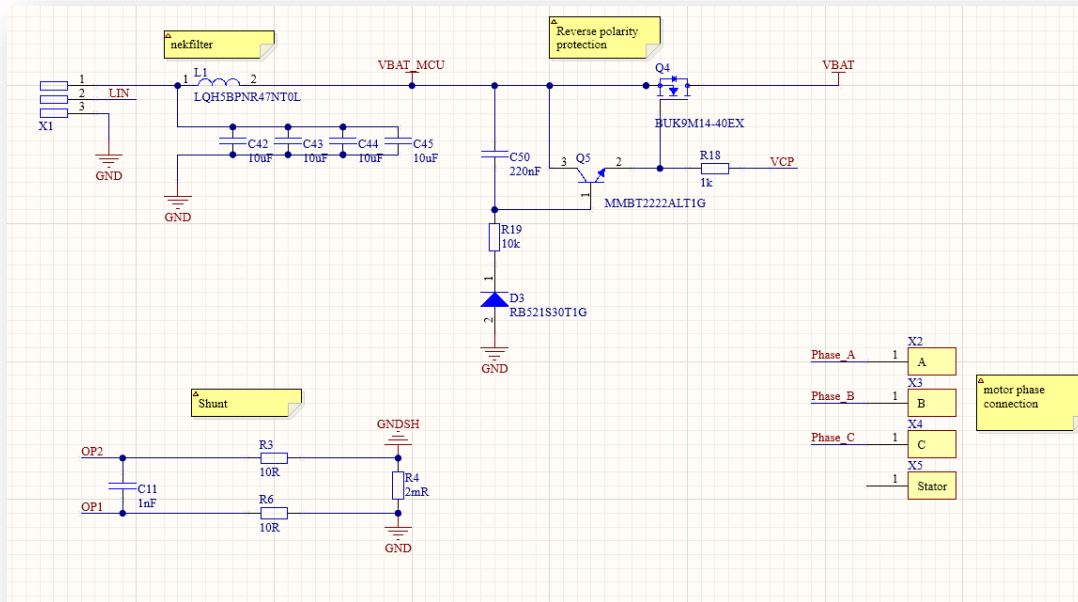

Maj Pavlin

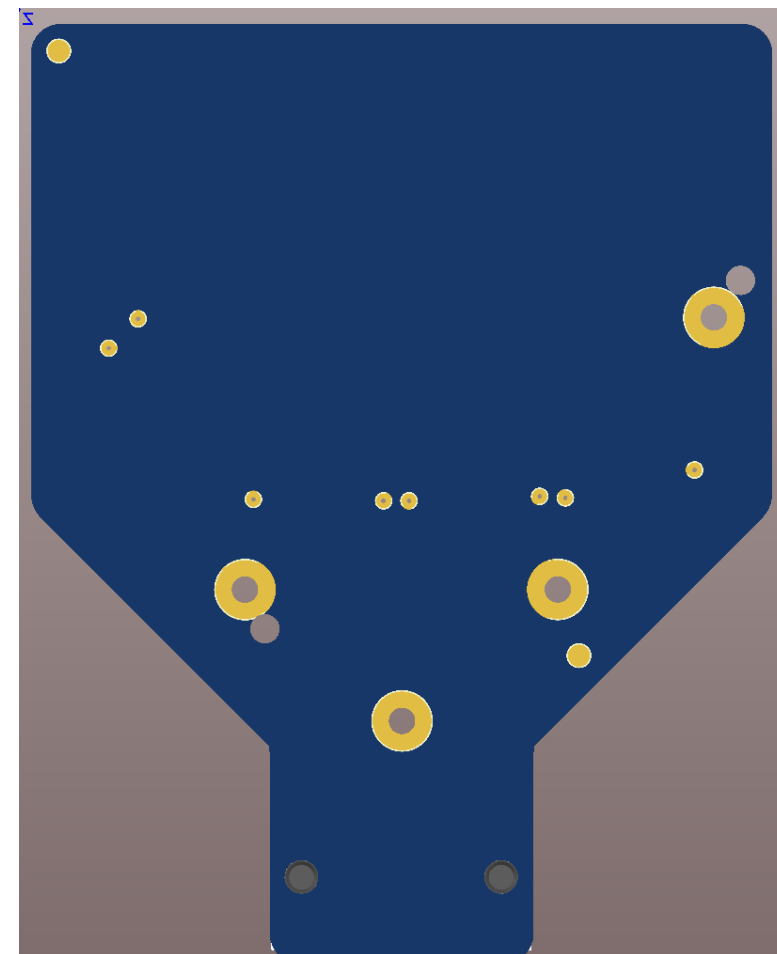
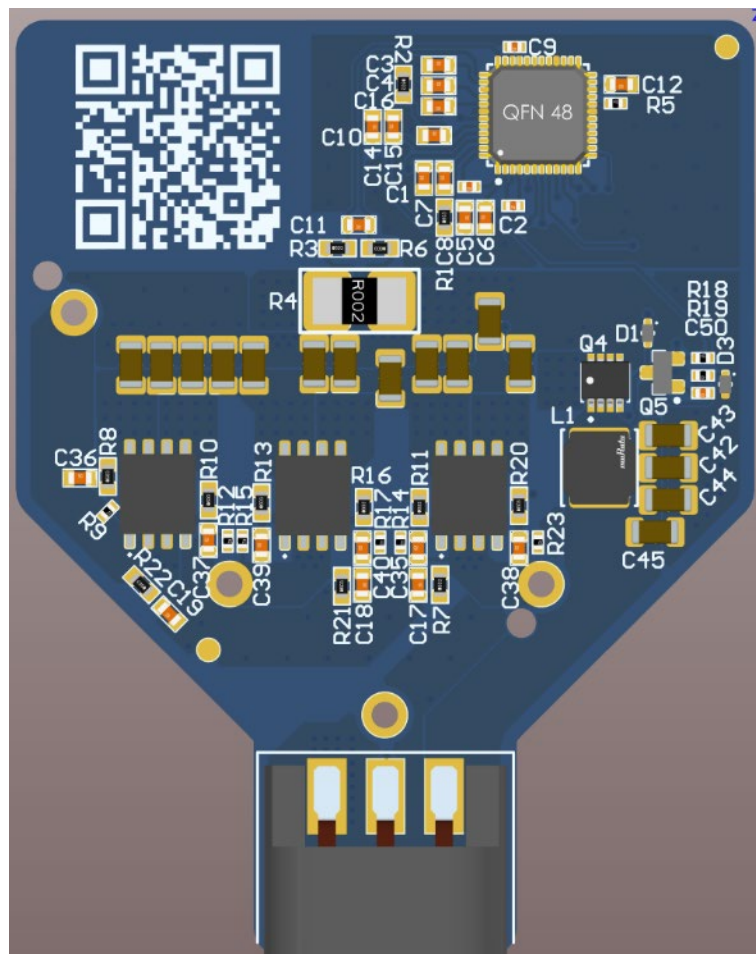

Maj Pavlin

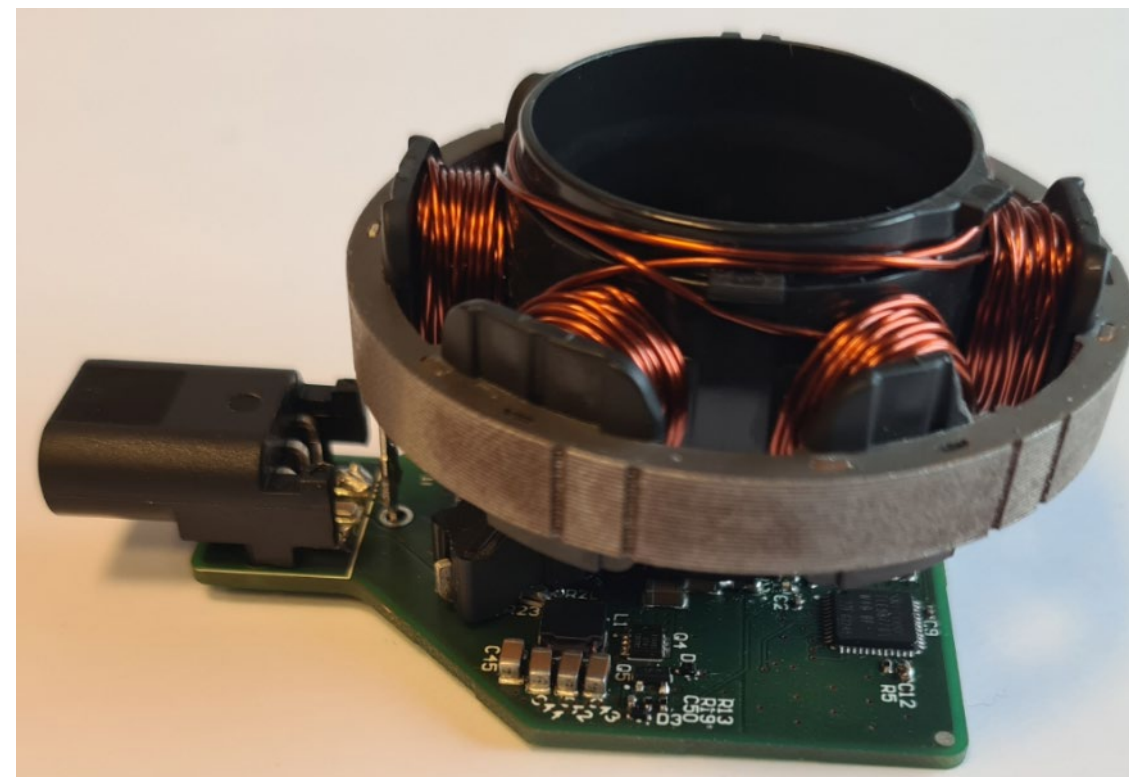
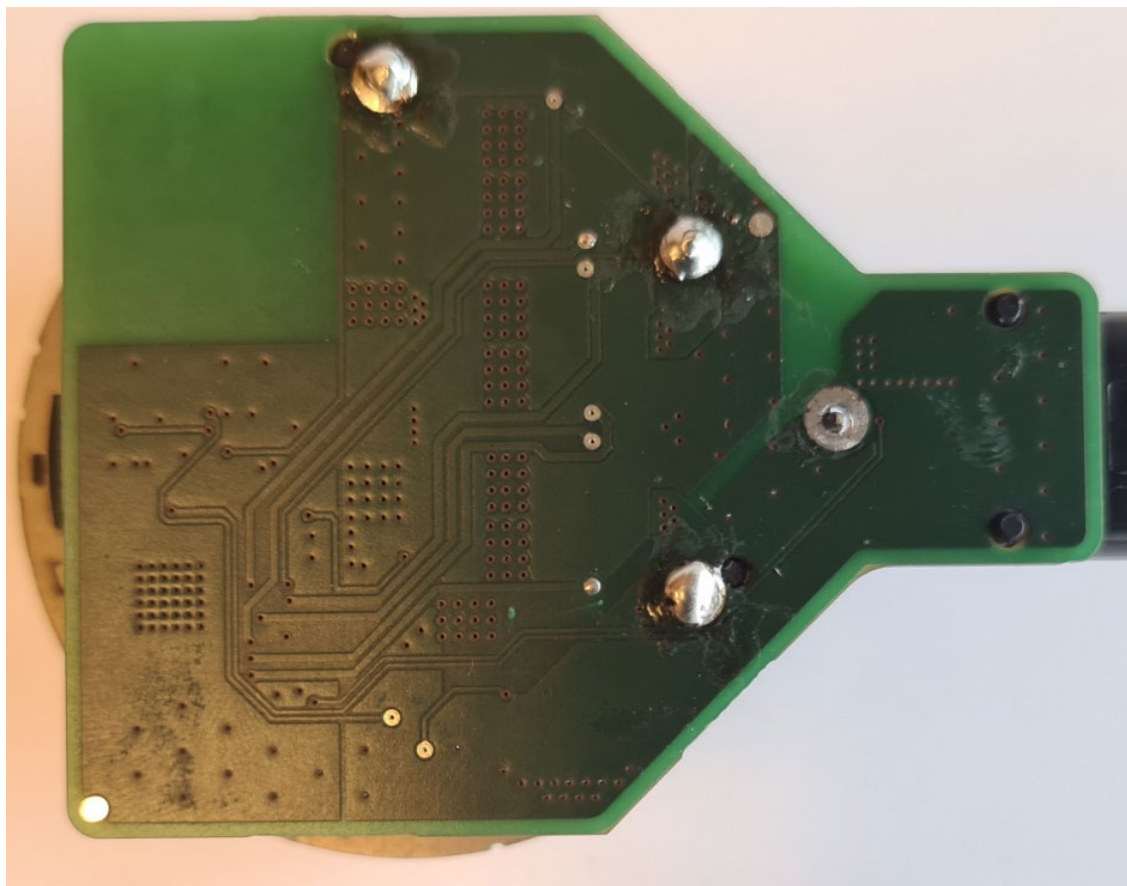

Maj Pavlin - BOM

No.	Query	Qty	Matches	Part	Part Description	Distributor/SKU	Unit Price	Line Total	Batch Total	Notes
1	CL31B106KBHNNI	16		Samsung CL31B106KBHNNNE	Multilayer Ceramic Capacitor, 10 uF, 50 V, ± 10%, X7R, 1206 [3216 Metric]	LCSC C89632 Stock: 231.890	0,0296	0,4736	473,6000	
2	IAUC60N04S6L04E	3		Infineon IAUC60N04S6L045HATMA1	Mosfet, N-Ch, 40V, 60A, Tdson Rohs Compliant: Yes Infineon IAUC60N04S6L045HATMA1	Mouser 726-IAUC60N04S6L045H Stock: 3.824 Tape & Reel	0,6310	1,8930	1.893,0000	
3	BUK9M14-40EX	1		Nexperia BUK9M14-40EX	BUK9M14-40E - N-channel 40 V, 14 mΩ logic level MOSFET in LFPK33	Mouser 771-BUK9M14-40EX Stock: 17.510 Tape & Reel	0,3290	0,3290	329,0000	
4	MMBT2222ALT1G	1		onsemi MMBT2222ALT1G	Bipolar (BJT) Transistor NPN 40V 600mA 300MHz 225mW Surface Mount SOT-23-3	LCSC C82460 Stock: 449.850	0,0206	0,0206	20,6000	
5	LQH5BPNR47NT0L	1		Murata LQH5BPNR47NT0L	Inductor Power Chip Shielded Wirewound 0.47uH 30% 100KHz Ferrite 4A 0.0144Ohm -----	Future Electronics 3022269 Stock: 0/▲ Tape & Reel	≈ 0,0739	≈ 0,0739	≈ 73,8947	
6	RB521S30T1G	1		onsemi RB521S30T1G	Rectifier Diode Schottky 0.2A 2-Pin SOD-523 T/R / DIODE SCHOTTKY 30V 200MA -----	RS 7916325 Stock: 2.100	≈ 0,0126	≈ 0,0126	≈ 12,6248	

Tekmovalec	cena tranzistorjev	Cena kondenzatorjev	Cena dušilk	Cena diod	Skupaj
Maj Pavlin	2,24 €	0,47 €	0,07 €	0,01 €	2,80 €

Tekmovalec	kvalifikacija	temp. območje	ostale zahteve	Cena komponent	Točke
Maj Pavlin	3	3	3	2,80 €	-5

Maj Pavlin - delovanje

- Izkoristek 85,0 %
- Prenihaj 1,4 V
- Padec napetosti 0,093 V
- Tok nasprotne polaritete 1 A

Tekmovalec	Osnovna	Izkoristek	Polariteta	Padec r	Prenihaj	Točke
Maj Pavlin	12	10	0	5	5	32

Maj Pavlin - CE

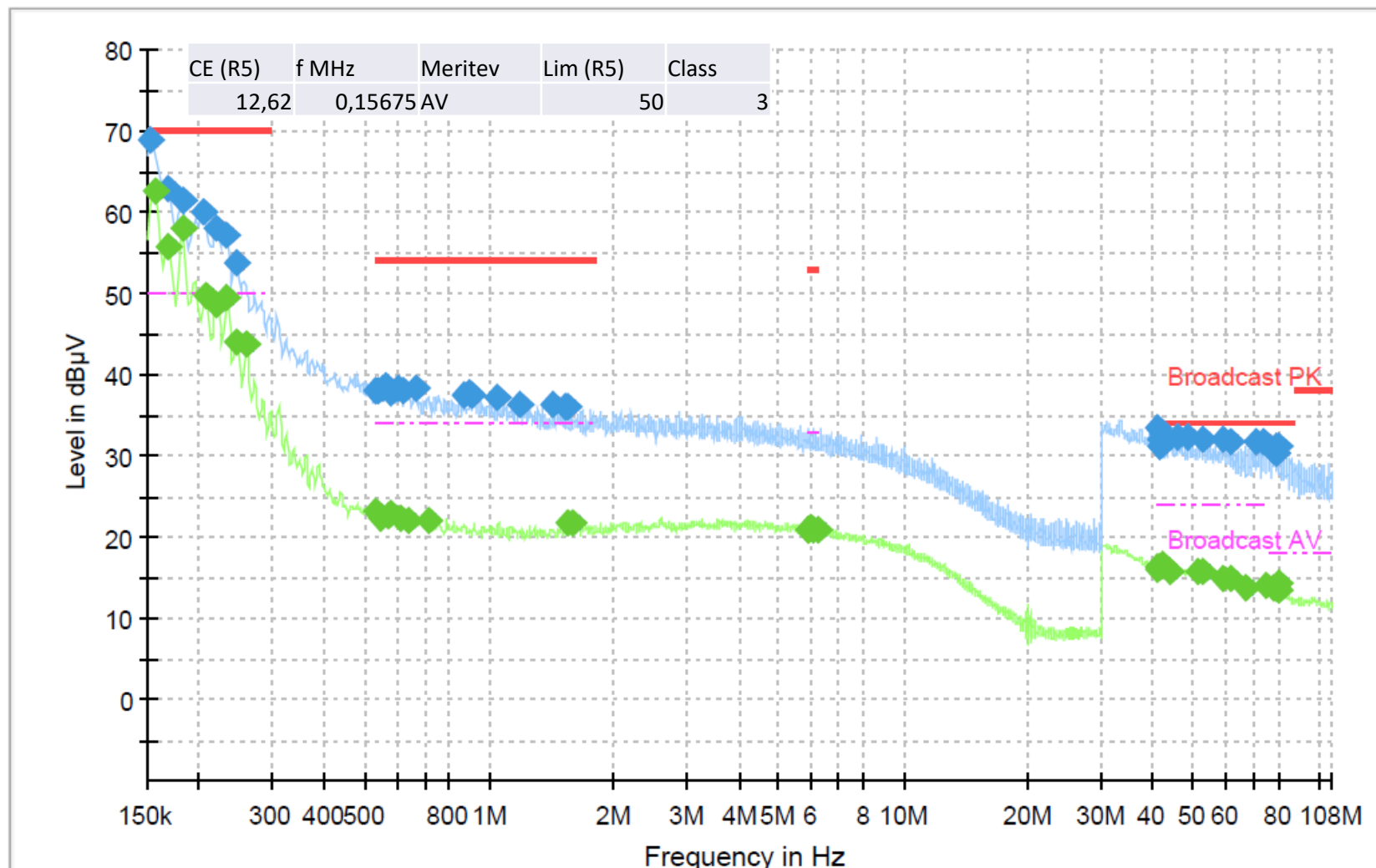

Maj Pavlin - VW

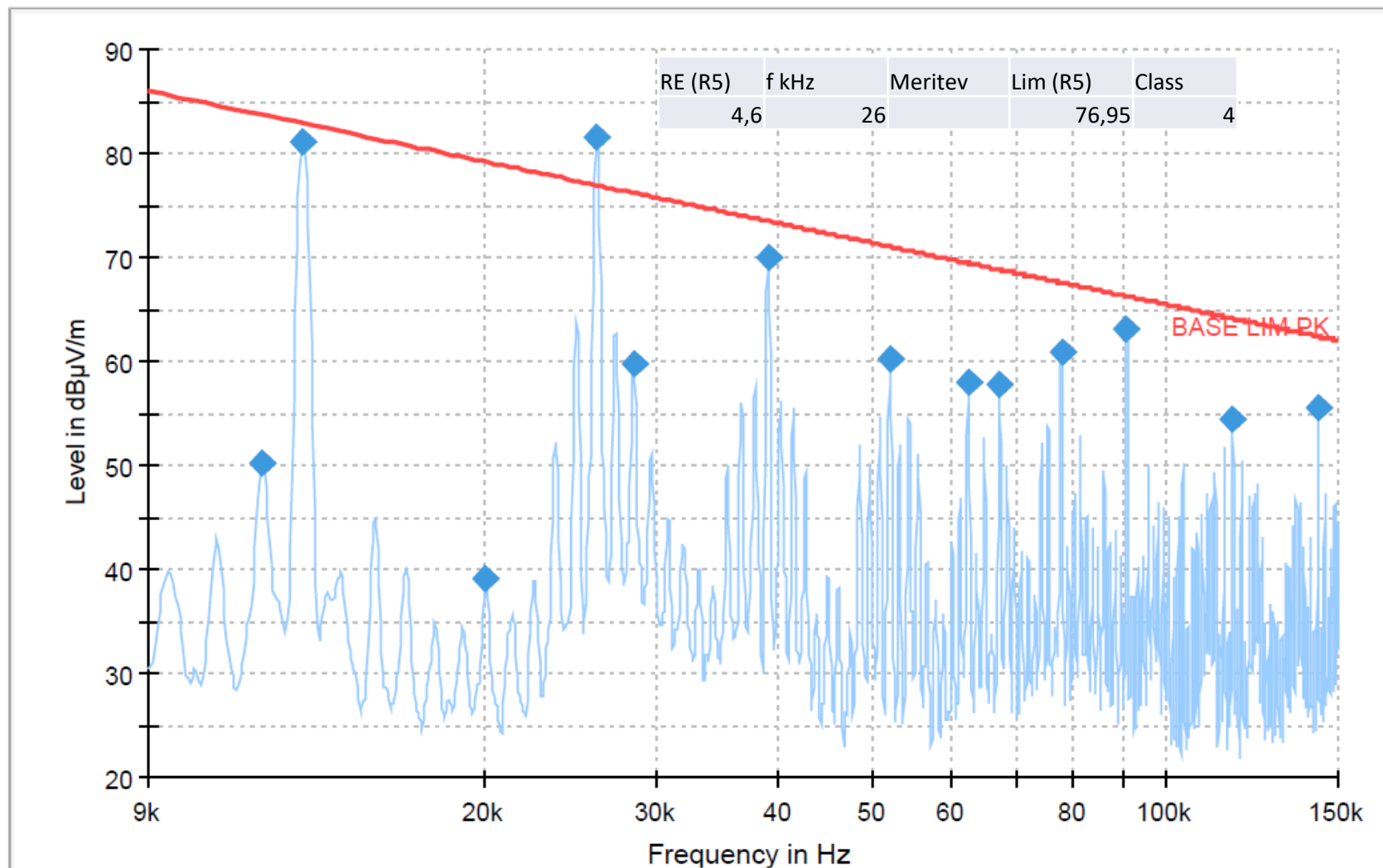

MaJ Pavlin - RE

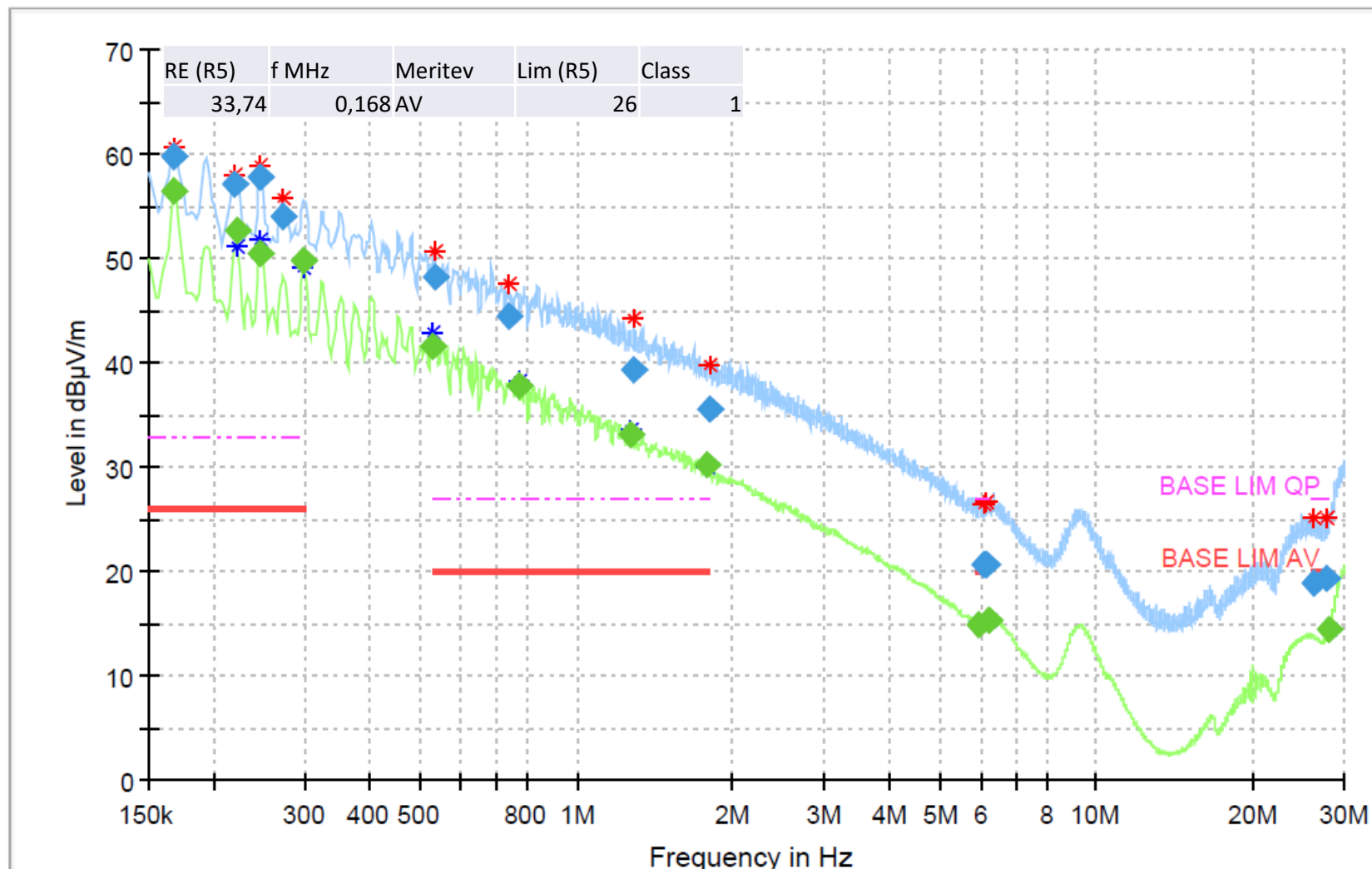

MaJ Pavlin – RE

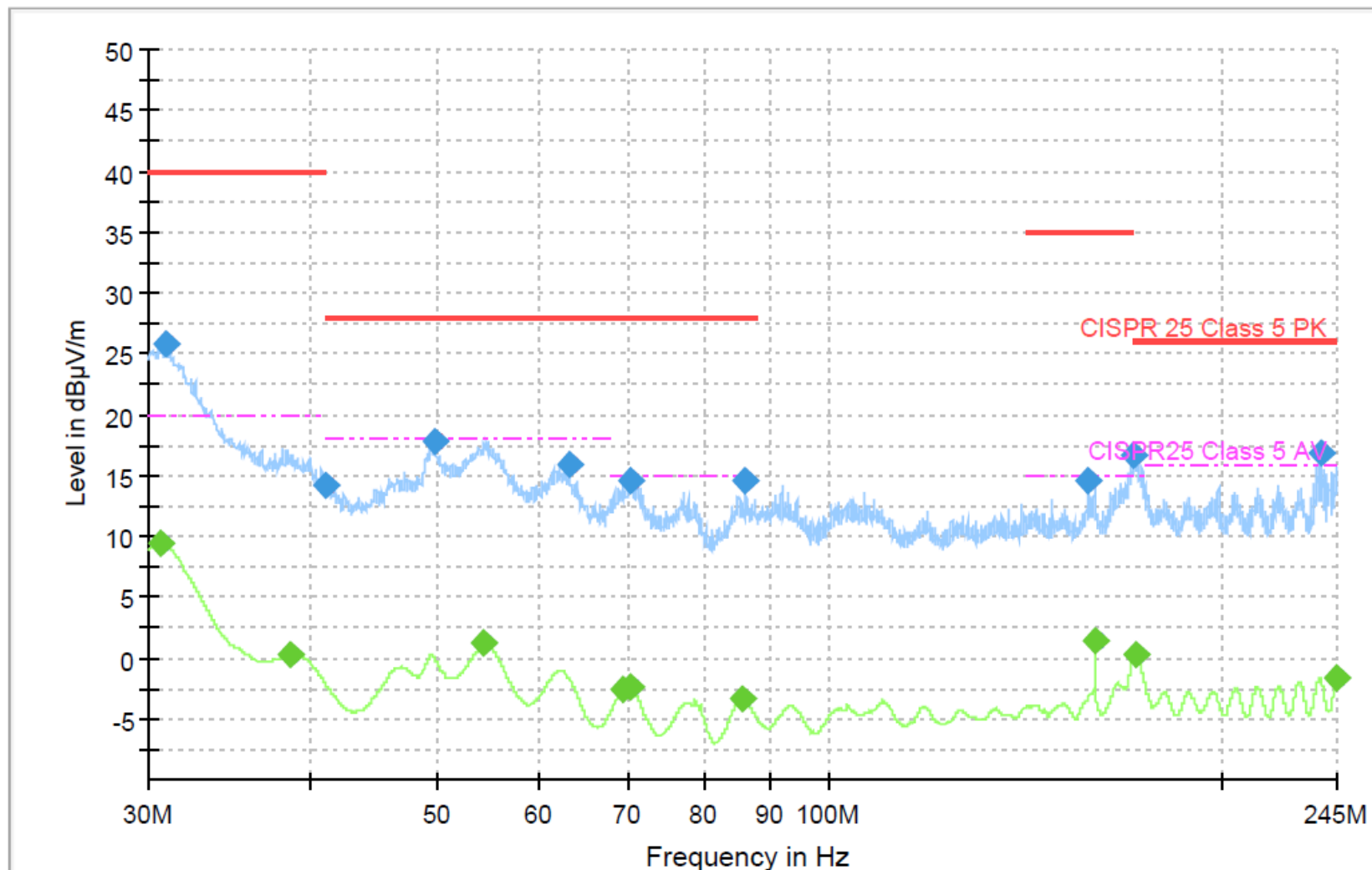

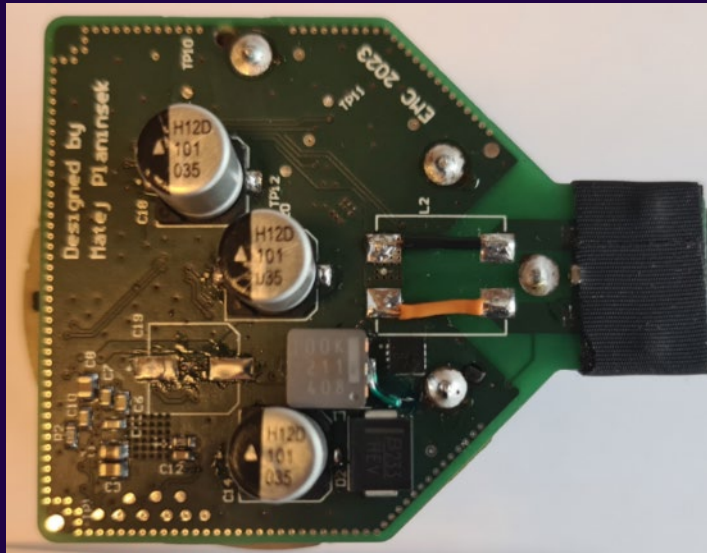

KOLEKTOR



Predstavitev

Matej Planinšek

Shema

Vhodno vezje

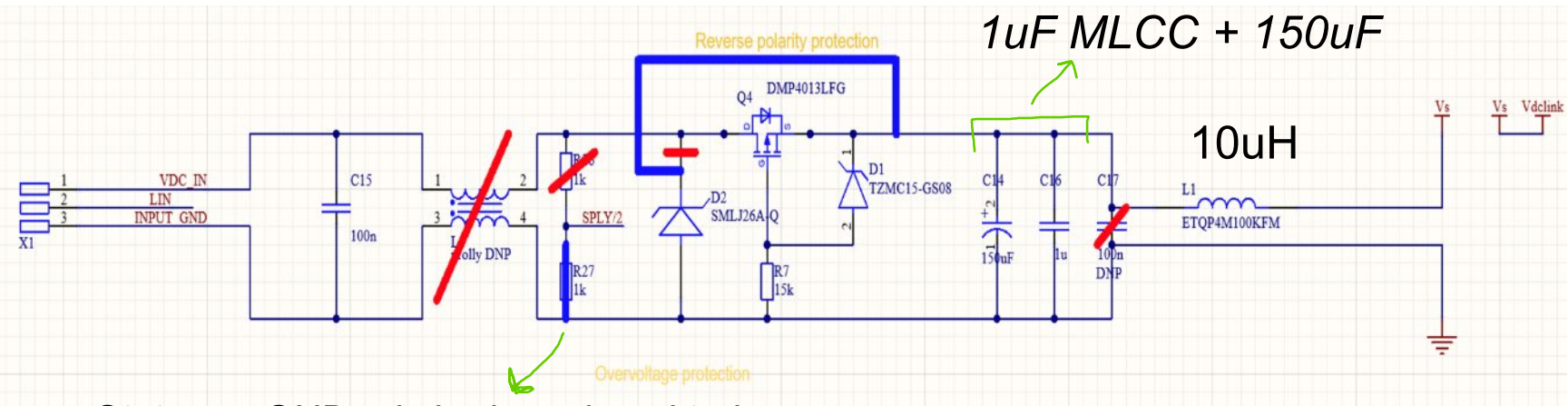

Stator na GND pri vhodnem konektorju



IAUC45N04S6L063H

OptiMOS™ - 6 Power-Transistor



Product Summary

V _{DS}	40	V
R _{DS(on),max}	6.3	mΩ
I _D	45	A

Features

- OptiMOS™ - power MOSFET for automotive applications
- Half-Bridge - N-channel - Enhancement mode - Logic Level
- AEC Q101 qualified
- MSL1 up to 260°C peak reflow
- 175°C operating temperature
- Green Product (RoHS compliant)

PG-TDSON-8-57

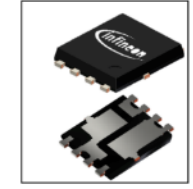

DC Link

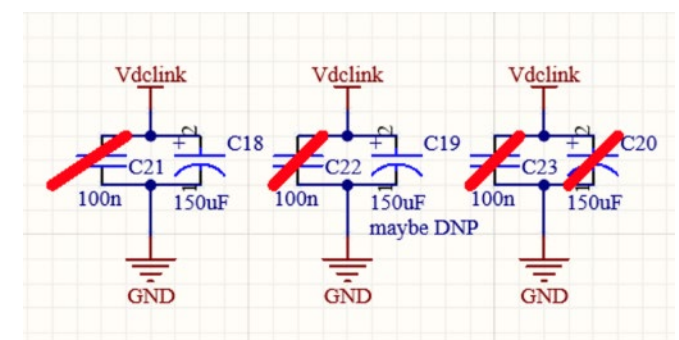

2x 150uF elektrolit 125C

Mosfet

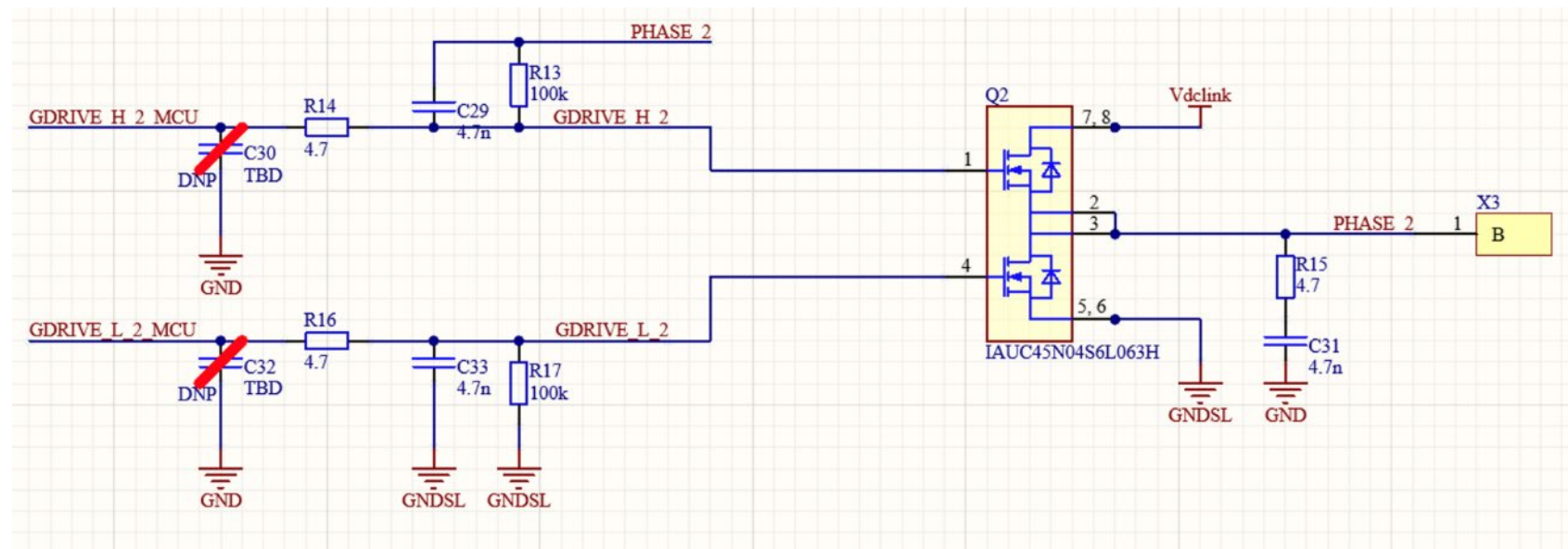

Simulacija preklopov

```

1 # produces waveforms for center-aligned PWM for mosfet constant-current gate drive
2 # with controlled slew rate in 3 intermediate phases for each switch event
3 # provides waveform for only one phase, run three times with different phase pwms for three phases
4 # output is LTSpice PWL syntax
5
6 #all times in us
7
8 swfreq = 13e3
9 pwm_duty = 0.3
10 idr_rise = 10e-9 #delete
11 deadtime = 600e-3 #us
12 off_cur = "-300m"
13 on_cur = "300m"
14
15
16
17 # full scale: 300mA steps of 10mA (starts at 20mA)
18 # half scale: 150mA steps of 5mA (starts at 10mA)
19
20 # time step is 50ns (50ns - 400ns)
21
22 # on slew rate control
23 on_slew_precharge_t = 100e-3 #us
24 on_slew_precharge_i = "80m"
25
26 on_slew_didt_t = 200e-3 #us
27 on_slew_didt_i = "20m"
28
29 on_slew_dvdt_t = 200e-3 #us
30 on_slew_dvdt_i = "80m"
31
32
33
34 full_on_i = "150m"
35 full_off_i = "-150m"
36
37
38 # off slew rate control
39 off_slew_precharge_t = 250e-3 #us
40 off_slew_precharge_i = "-260m"
41
42 off_slew_dvdt_t = 200e-3 #us
43 off_slew_dvdt_i = "-80m"
44
45 off_slew_didt_t = 150e-3 #us
46 off_slew_didt_i = "-20m"
47

```

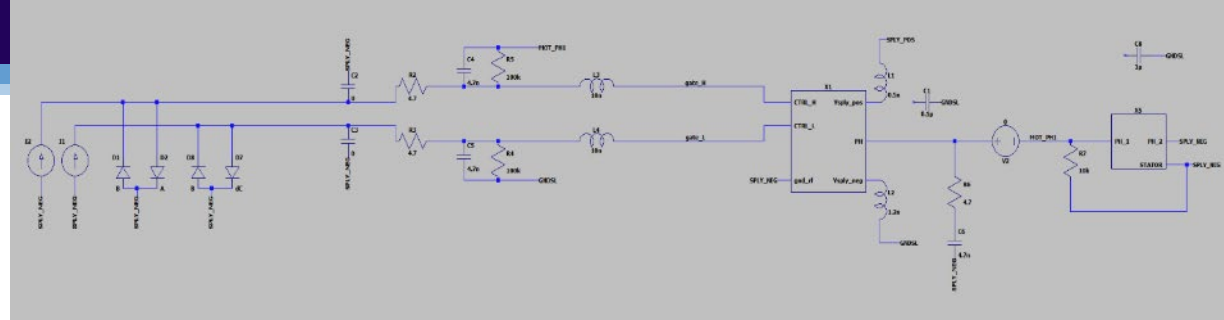
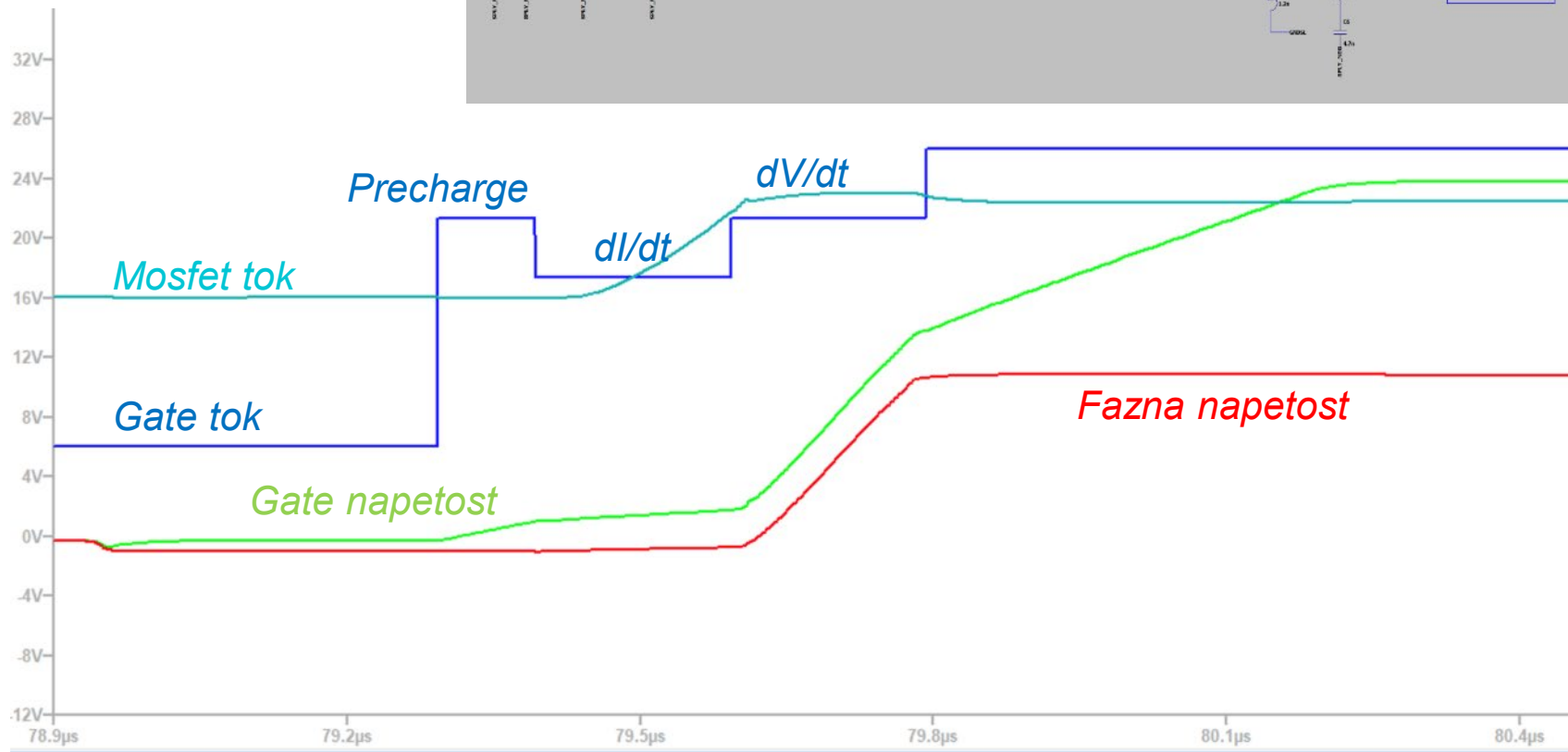

Python iz parametrov generira PWL za LTSpice

100nF MLCC v DC link = 200Mhz oscilacija?? →

Tokovne zanke

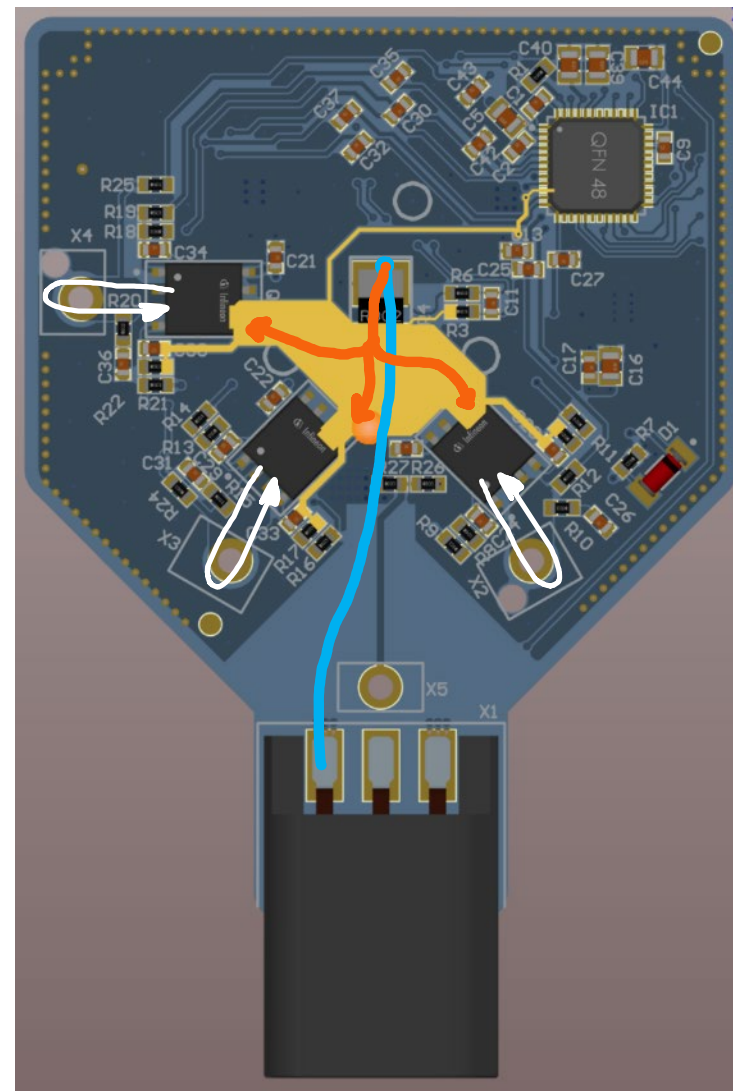
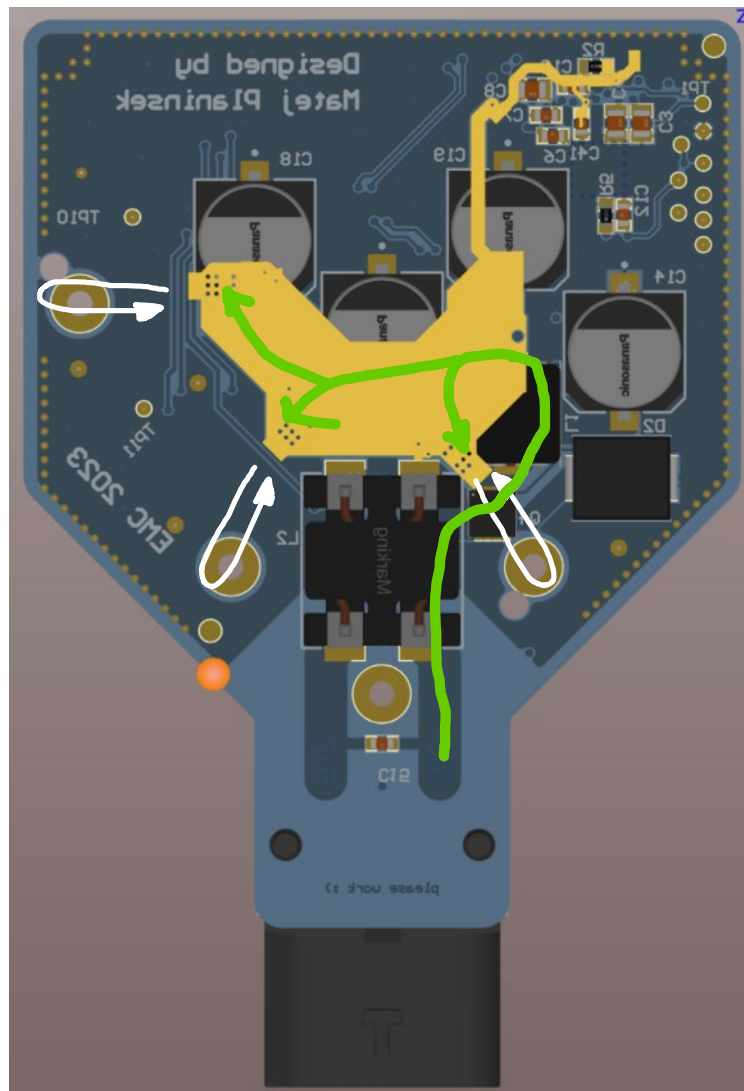

Priklop statorja – konduktivne meritve

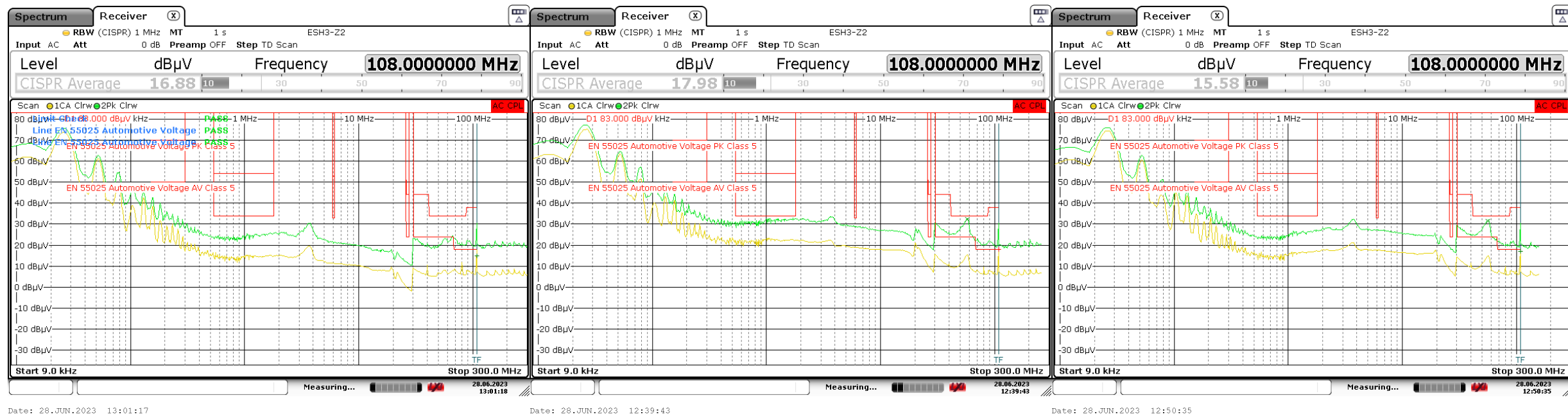

GND

nepriklopljen

1k-1k delilnik med + in - napajanje

Preliminarne meritve

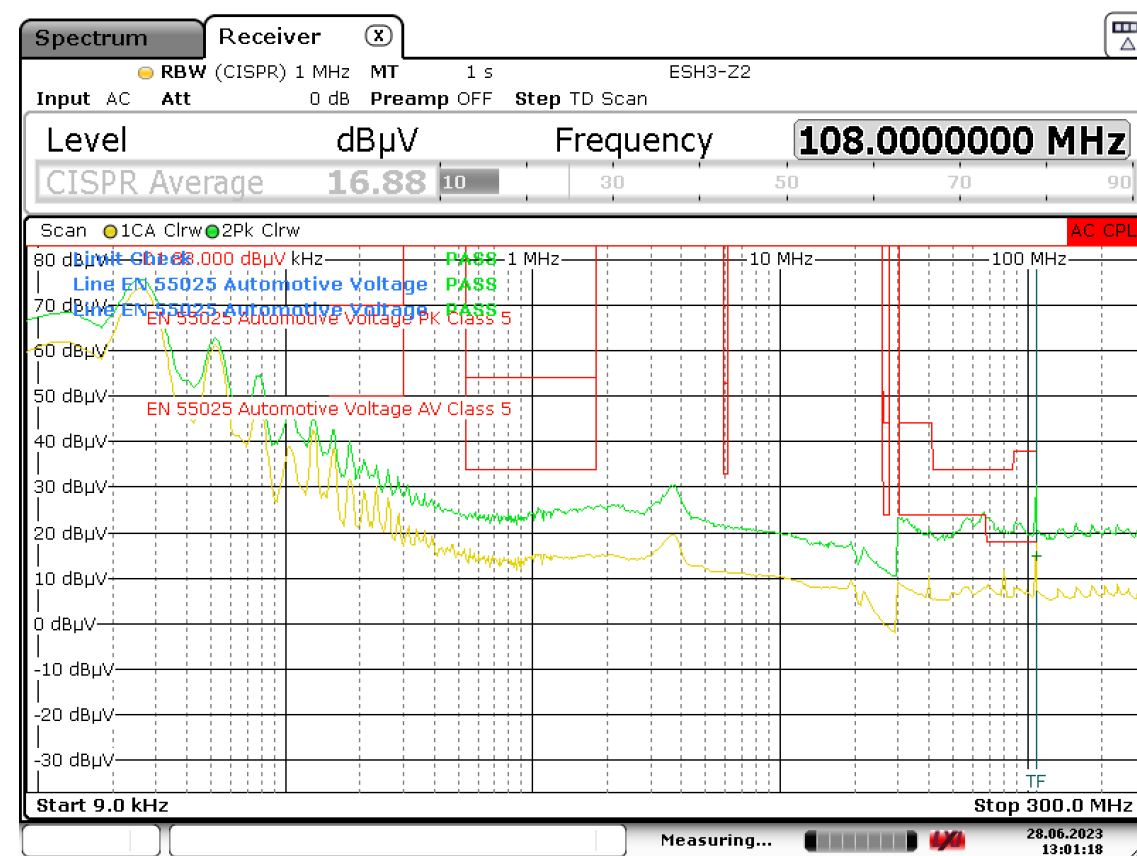
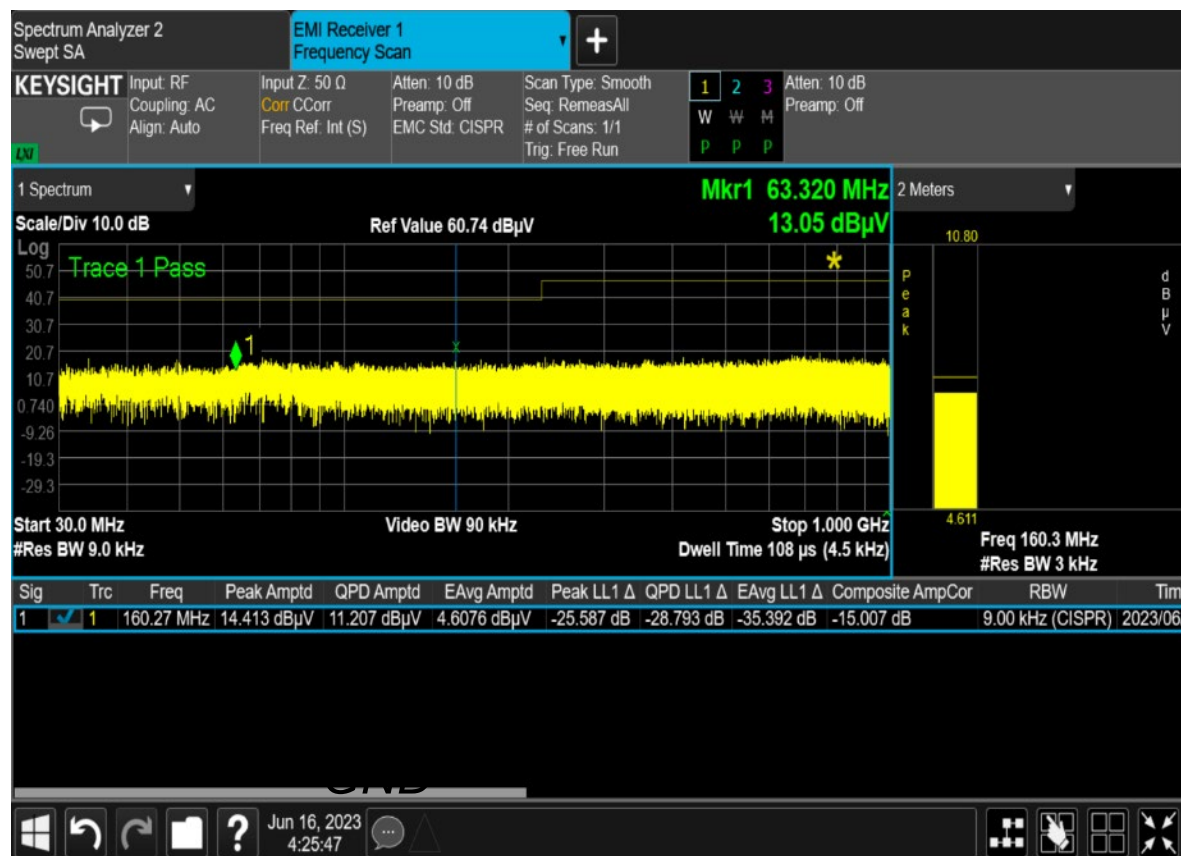

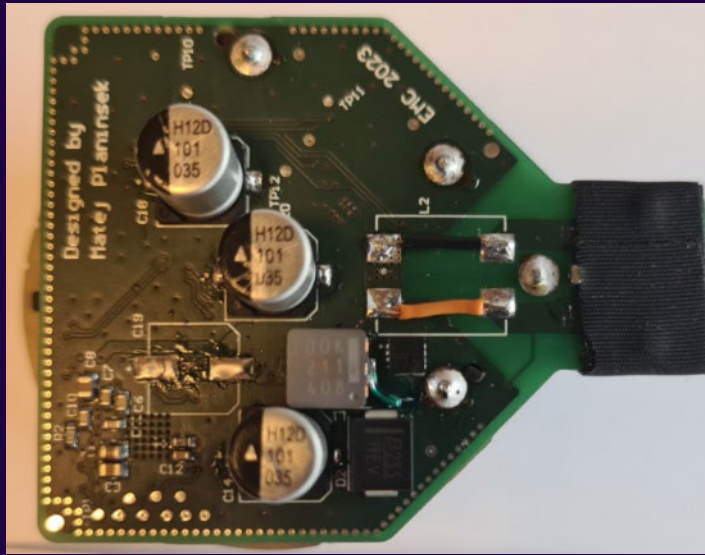

KOLEKTOR



Rezultati

Matej Planinšek

Matej Planinšek

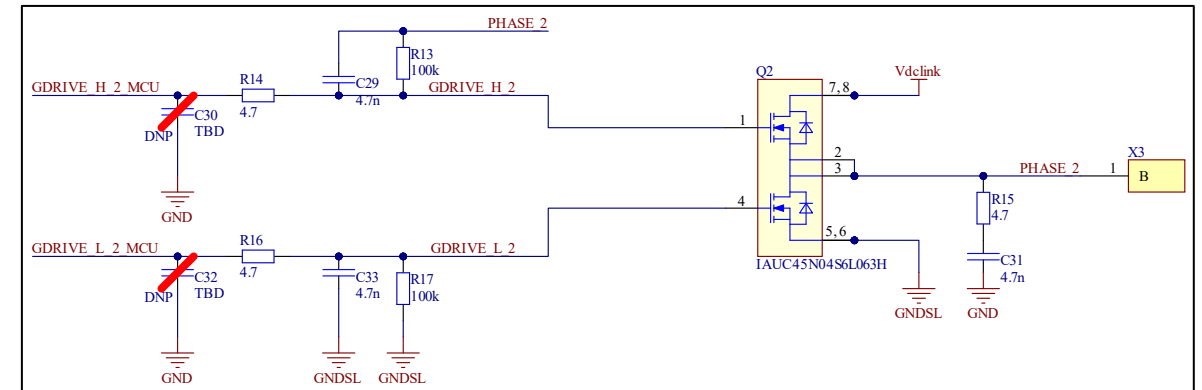
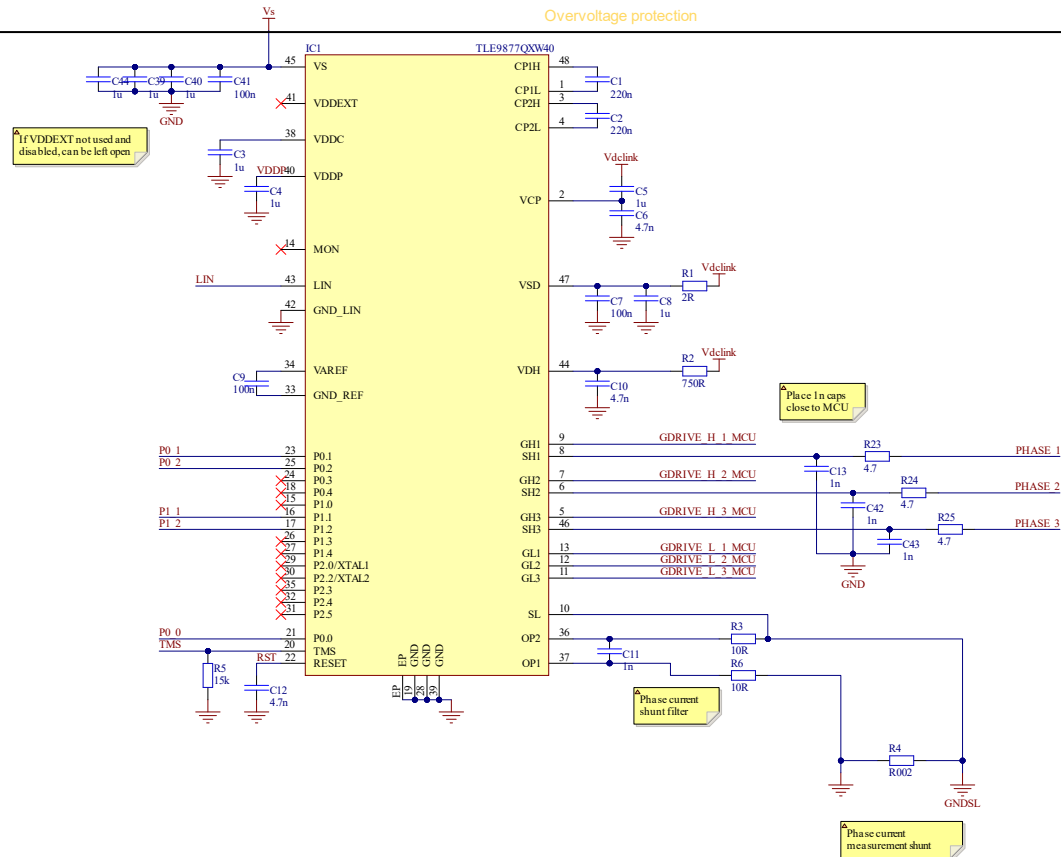
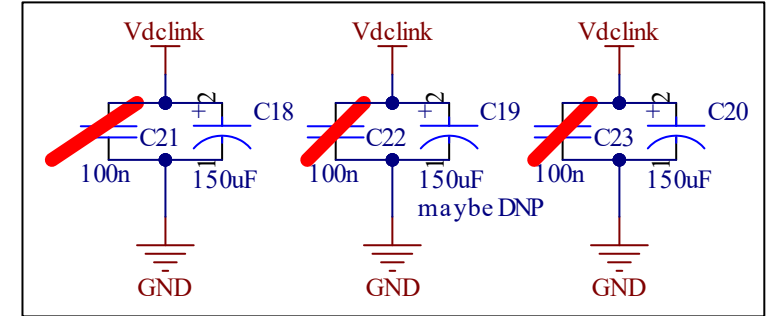
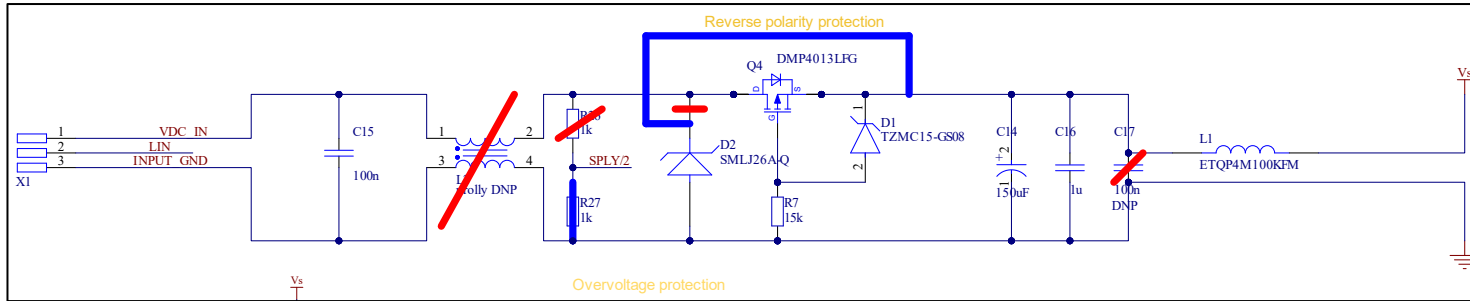

Matej Planinšek

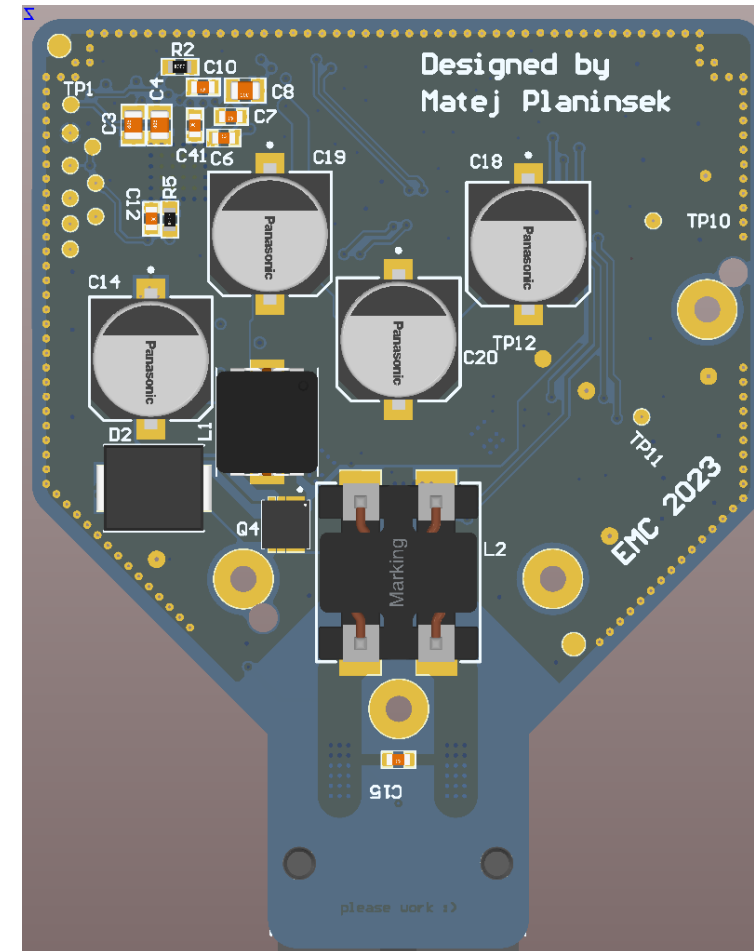
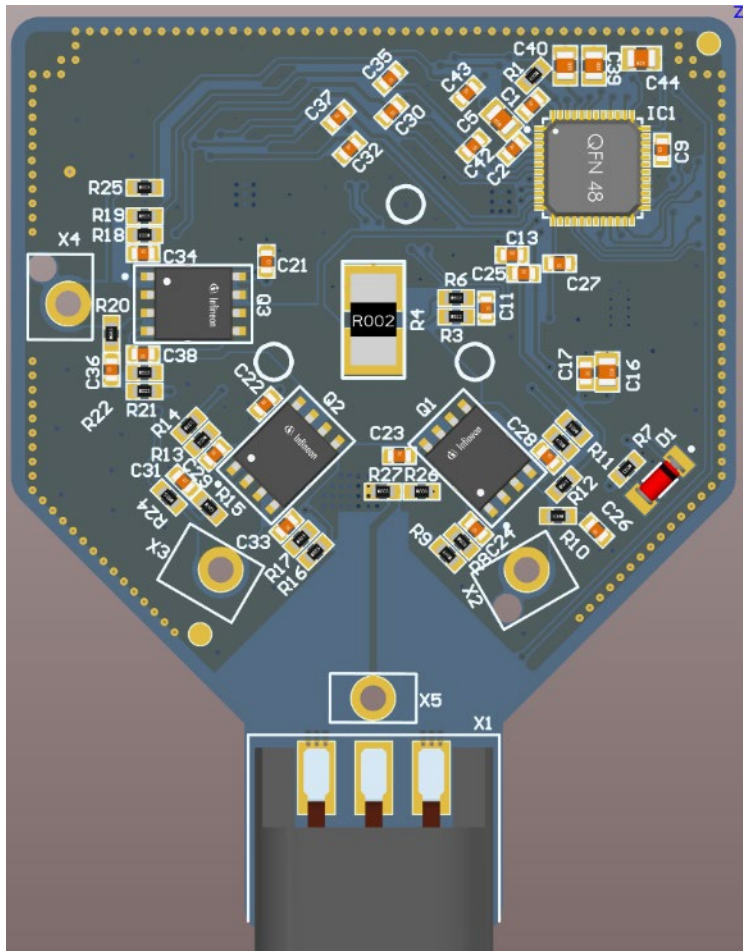

Matej Planinšek

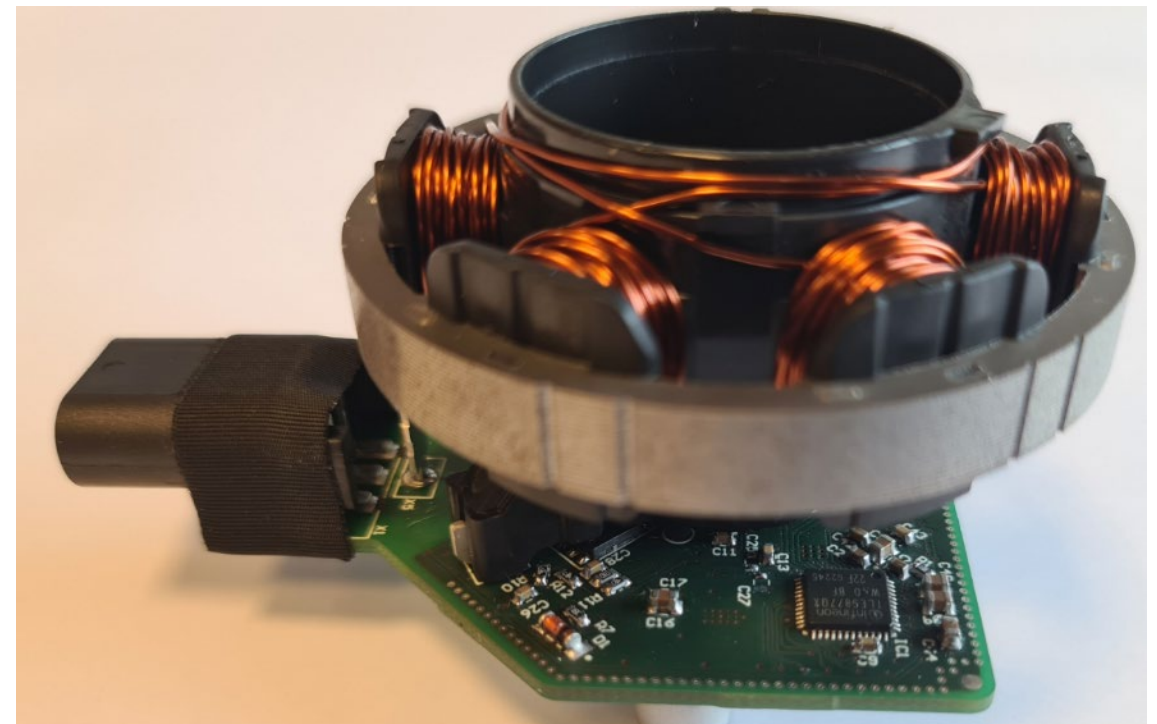
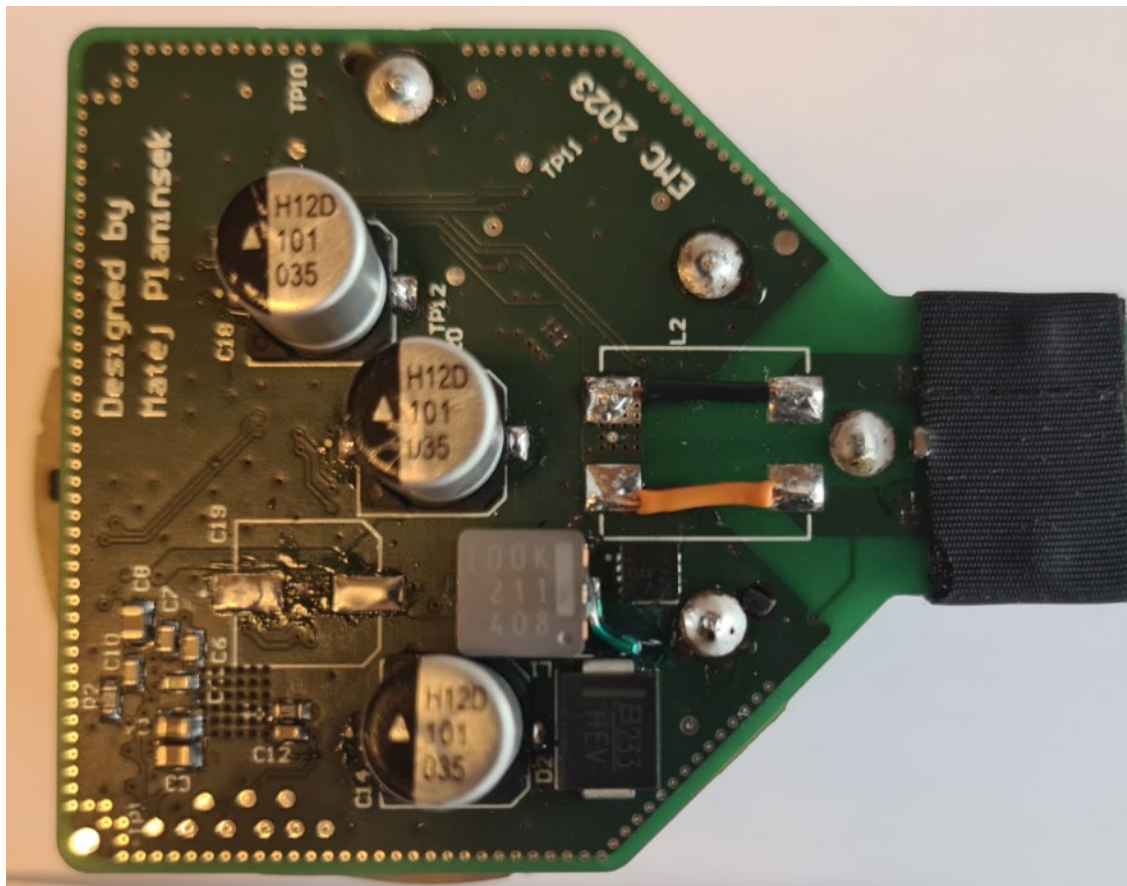

Matej Planinšek – BOM

No.	Query	Qty	Matches	Part	Part Description	Distributor/SKU	Unit Price	Line Total	Batch Total	Notes
1	CL21B105KBFNNM	8	✓	Samsung CL21B105KBFNNNE	Multilayer Ceramic Capacitor, 1 uF, 50 V, ± 10%, X7R, 0805 [2012 Metric]	LCSC C28323 Stock: 1.268.600	0,0056	0,0448	44,8000	
2	TZMC15-GS08	1	✓	Vishay TZMC15-GS08	Zener Diode Single 15V 5% 30Ohm 500mW Automotive 2-Pin Mini-MELF SOD-80 T/R	RS 6997893 Stock: 8.500	≈ 0,0149	≈ 0,0149	≈ 14,9203	
3	ETQP4M100KFM	1	📄	Panasonic ETQP4M100KFM	Ind Power Chip Shielded/Molded Wirewound 10uH 20% 100kHz Metal 6A	Farnell 2965285 Stock: 1.874	0,3710	0,3710	371,0000	
4	IAUC45N04S6L063	3	✓	Infineon IAUC45N04S6L063HATMA1	Mosfet, N-Ch, 40V, 45A, Tdson Rohs Compliant: Yes Infineon IAUC45N04S6L063HATMA1	Farnell 3648080 Stock: 8.765	0,5700	1,7100	1.710,0000	
5	DMP4013LFGQ-7	1	✓	Diodes Inc. DMP4013LFGQ-7	Mosfet, P-Ch, 40V, 10.3A, Powerdi 3333 Rohs Compliant: Yes Diodes Inc.	Arrow Electronics DMP4013LFGQ-7 Stock: 1.550 Cut Tape	≈ 0,2940	≈ 0,2940	≈ 293,9846	
6	AEH0810101M035	3	✓	AVX AEH0810101M035R	Capacitor Aluminum 100uF 35Vdc 20% Radial Can Cylindrical Can 220mA 2000 hr	TTI AEH0810101M035R Stock: 0 ⚠️ Tape & Reel	≈ 0,1932	≈ 0,5795	≈ 579,5295	

Tekmovalec	cena tranzistorjev	Cena kondenzatorjev	Cena dušilk	Cena diod	Skupaj
Matej Planinšek	2,00 €	0,62 €	0,37 €	0,01 €	3,01 €

Tekmovalec	kvalifikacija	temp. območje	ostale zahteve	Cena komponent	Točke
Matej Planinšek	3	3	3	3,01 €	-6,05

Matej Planinšek – delovanje

- Izkoristek 85,12 %
- Prenihaj 1,4 V
- Padec napetosti 0,183 V
- Tok nasprotne polaritete 0,1 mA

Tekmovalec	Osnovna	Izkoristek	Polariteta	Padec r	Prenihaj	Točke
Matej Planinšek	12	10	5	5	5	37

Matej Planinšek – CE

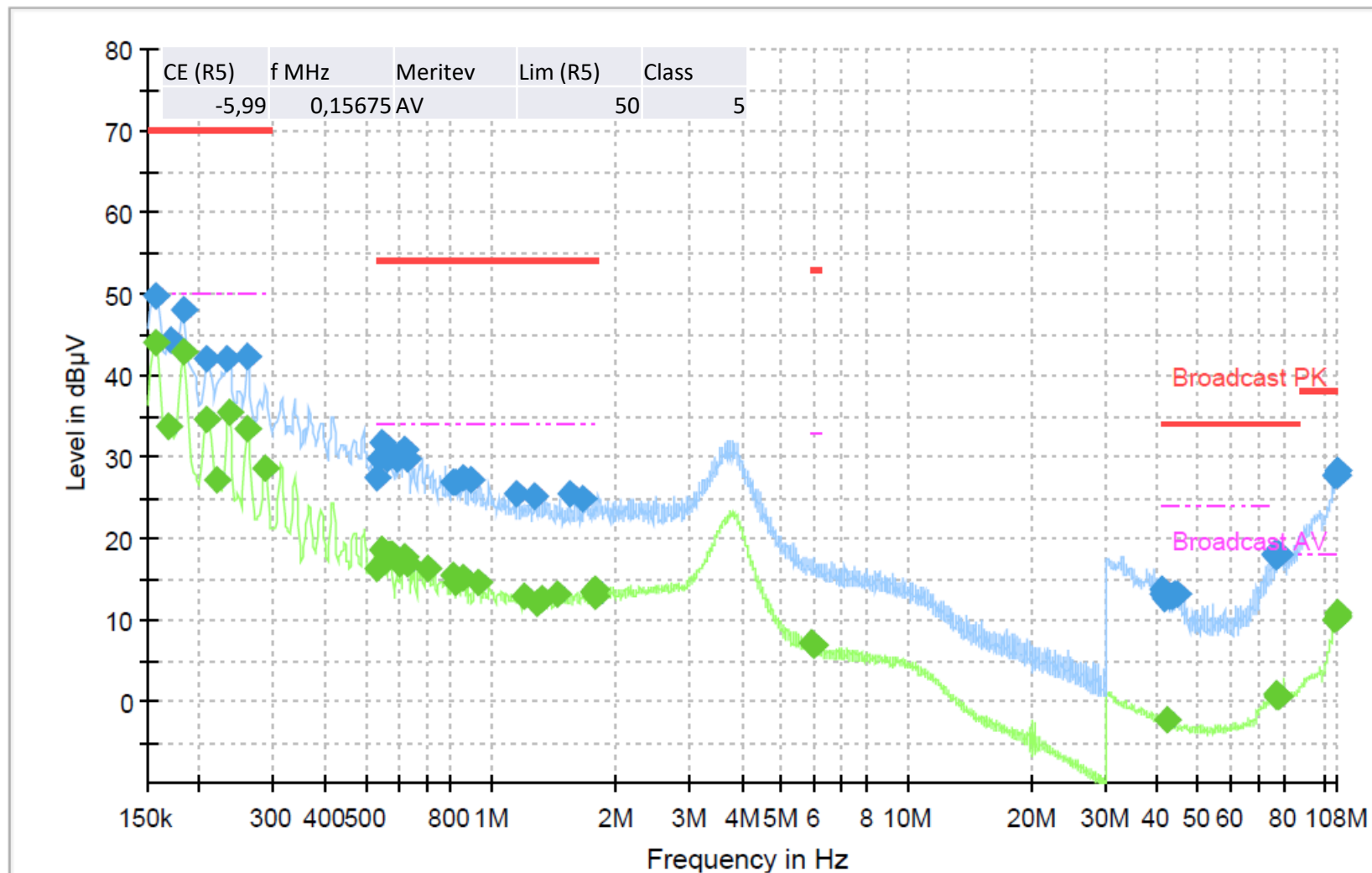

Matej Planinšek – VW

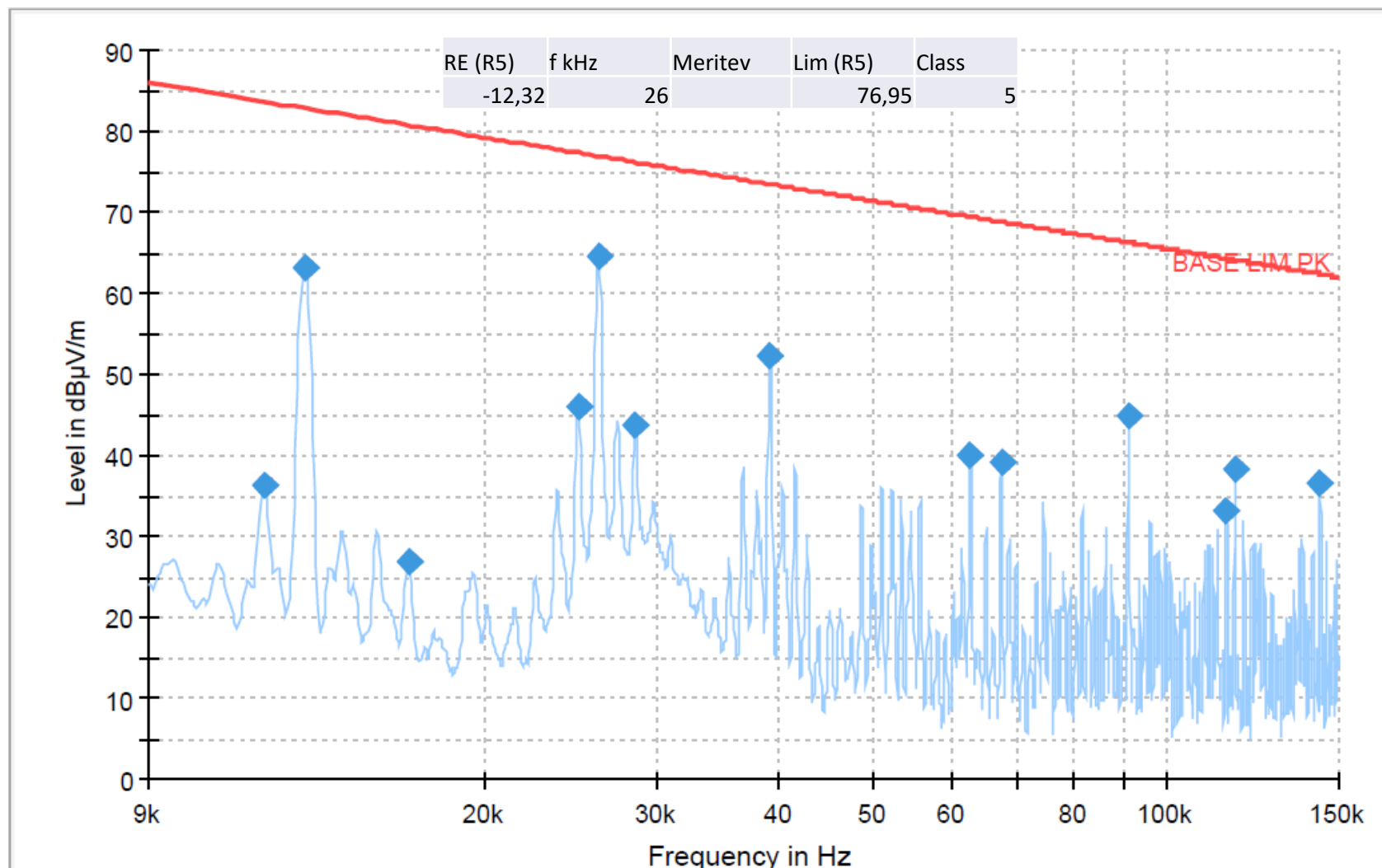

Matej Planinšek – RE

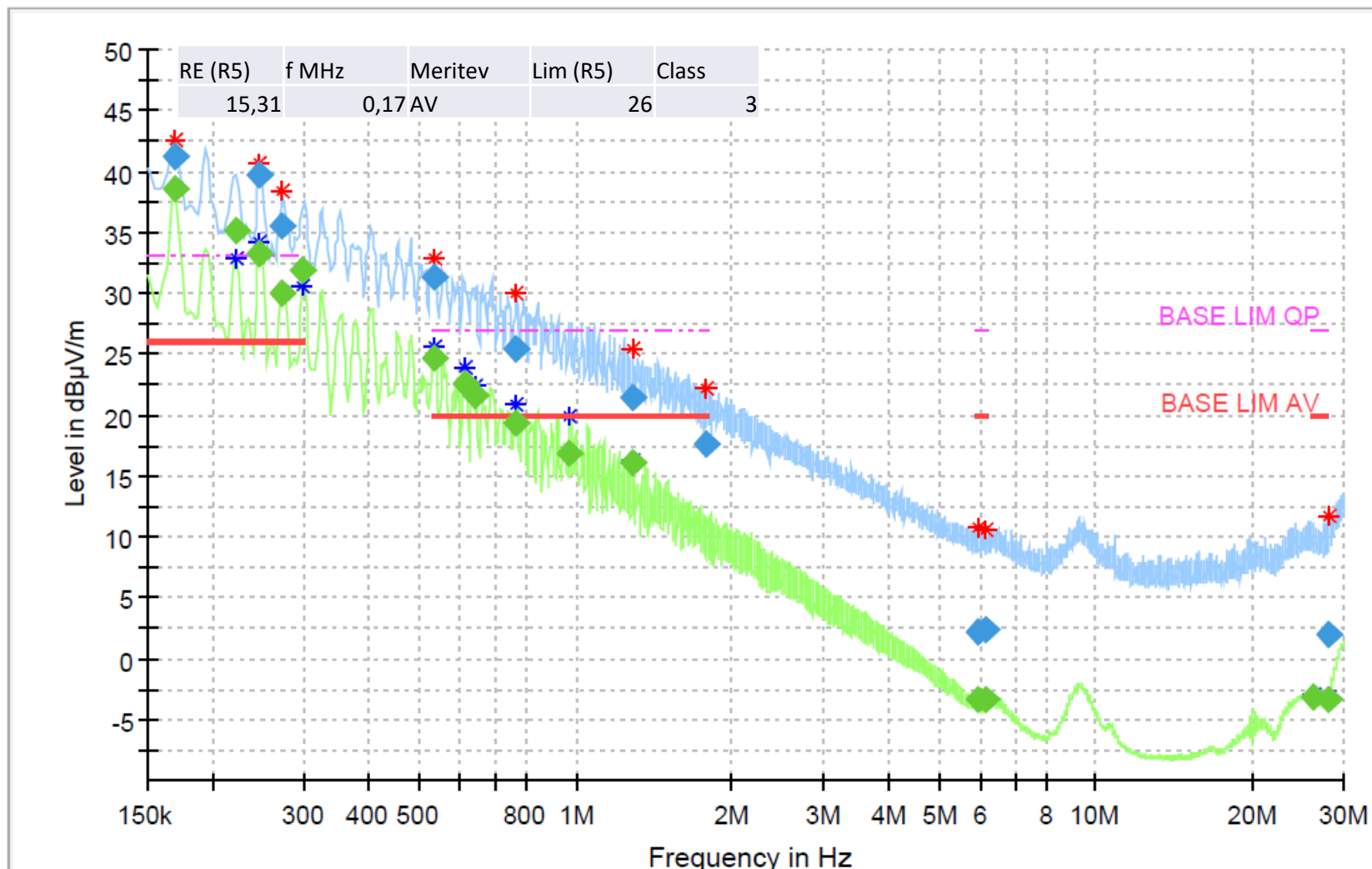

Matej Planinšek – RE

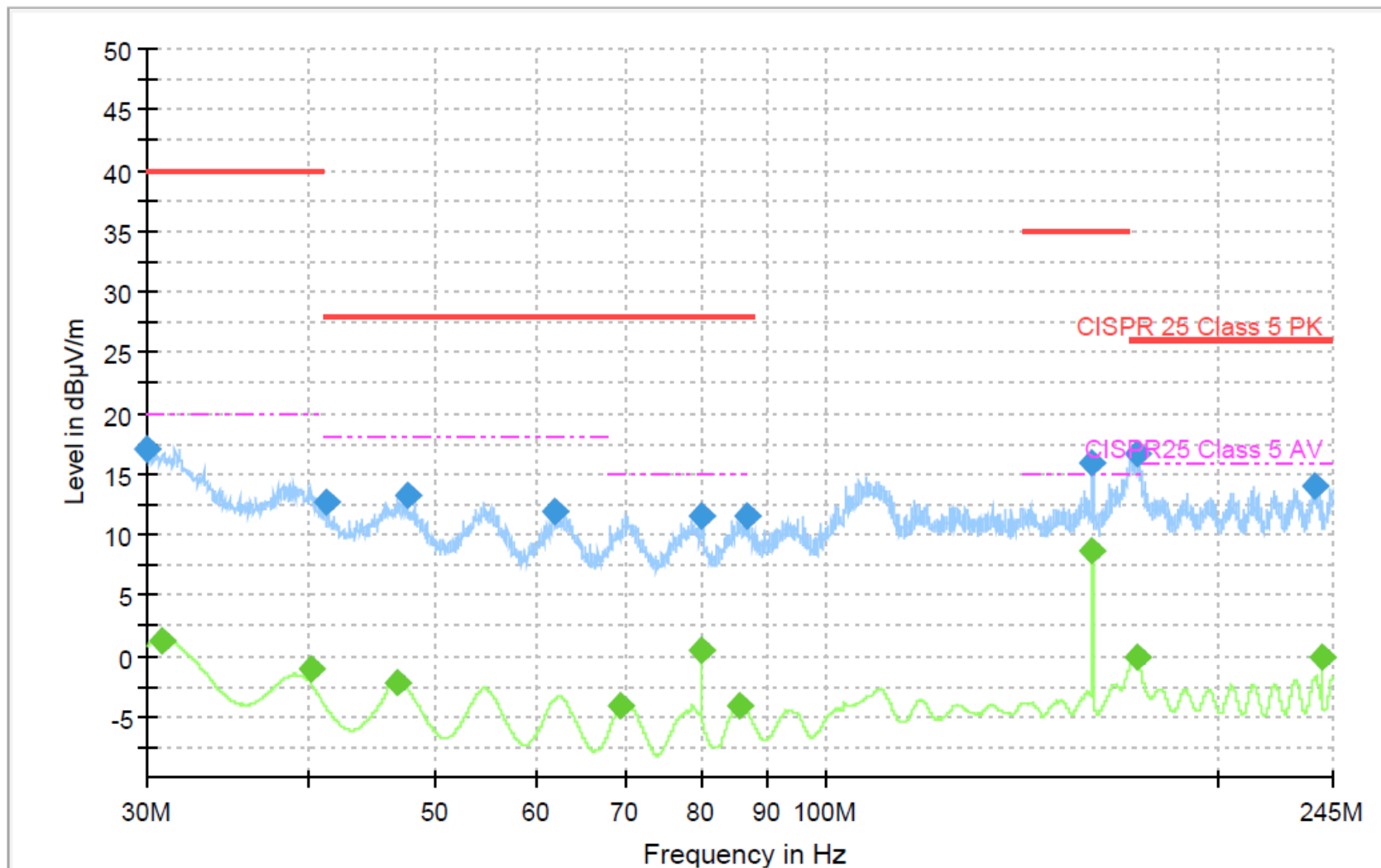

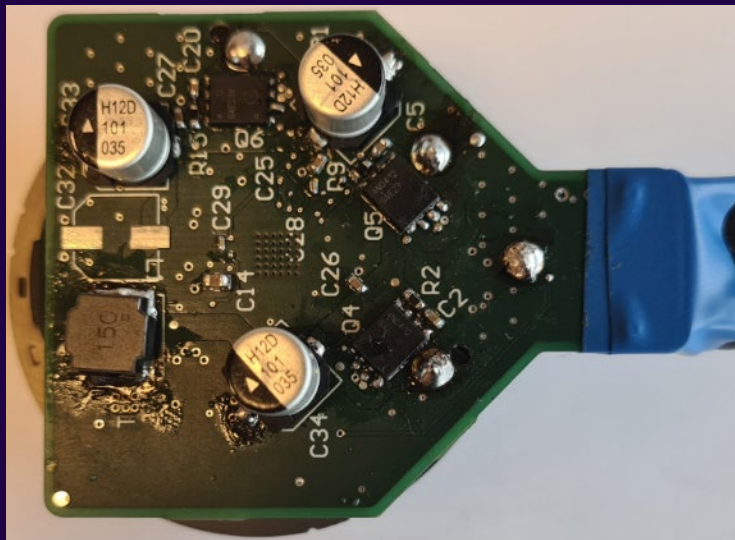

KOLEKTOR



Predstavitev

Tjaž Uran Oblak

Shema

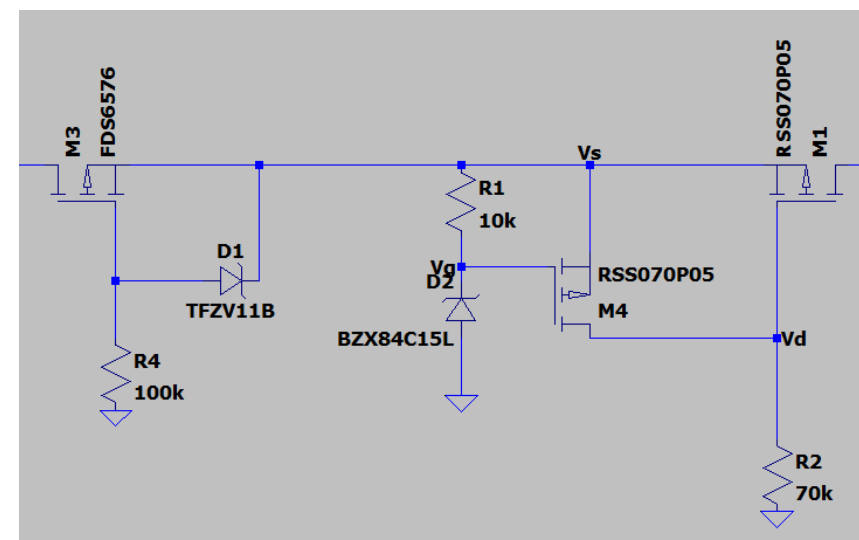
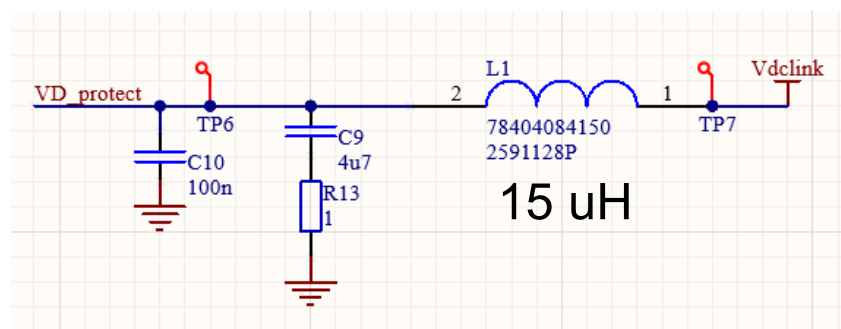
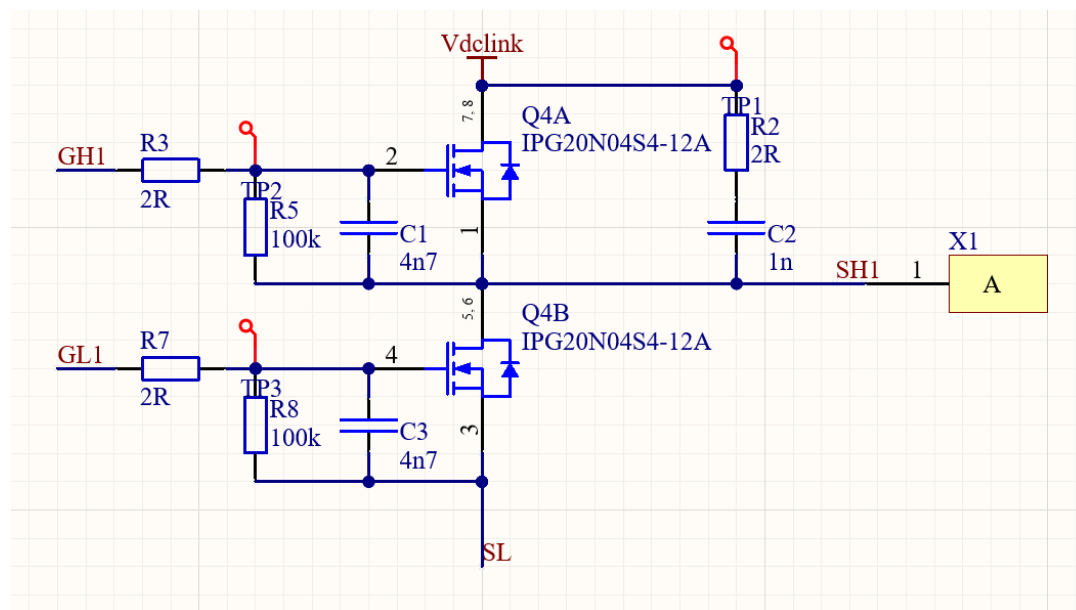

DC link:

- 4 100u elektrolitski kondenzatorji
- 3 100n keramični kondenzatorji

Izračuni, simulacije

Prenapetost

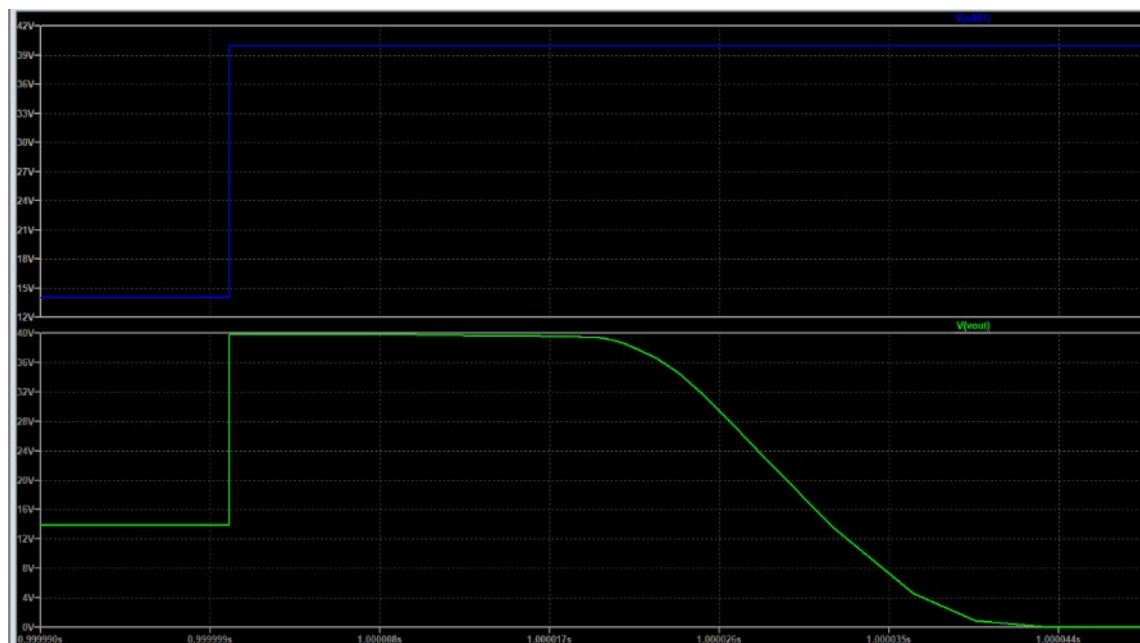

Napačna polariteta

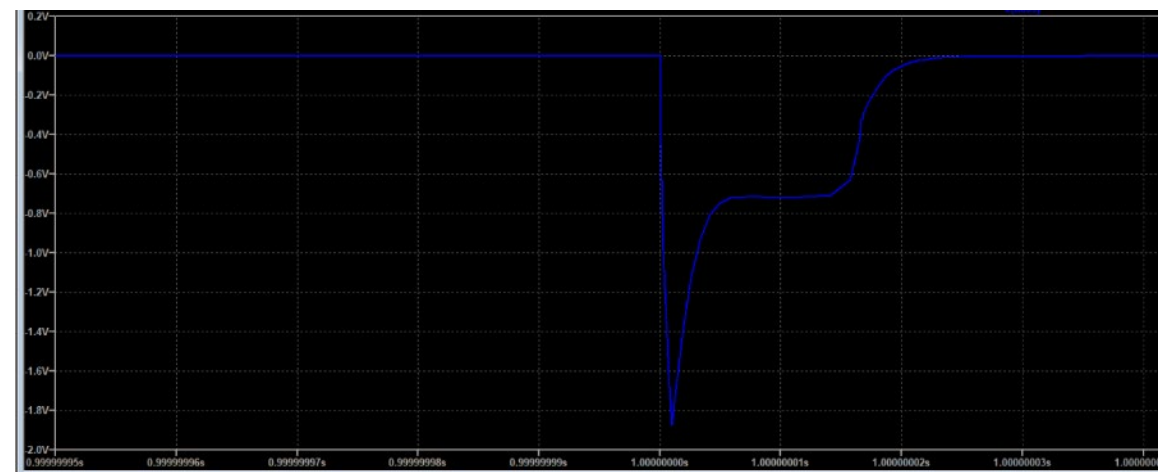

Načrt tiskanega vezja

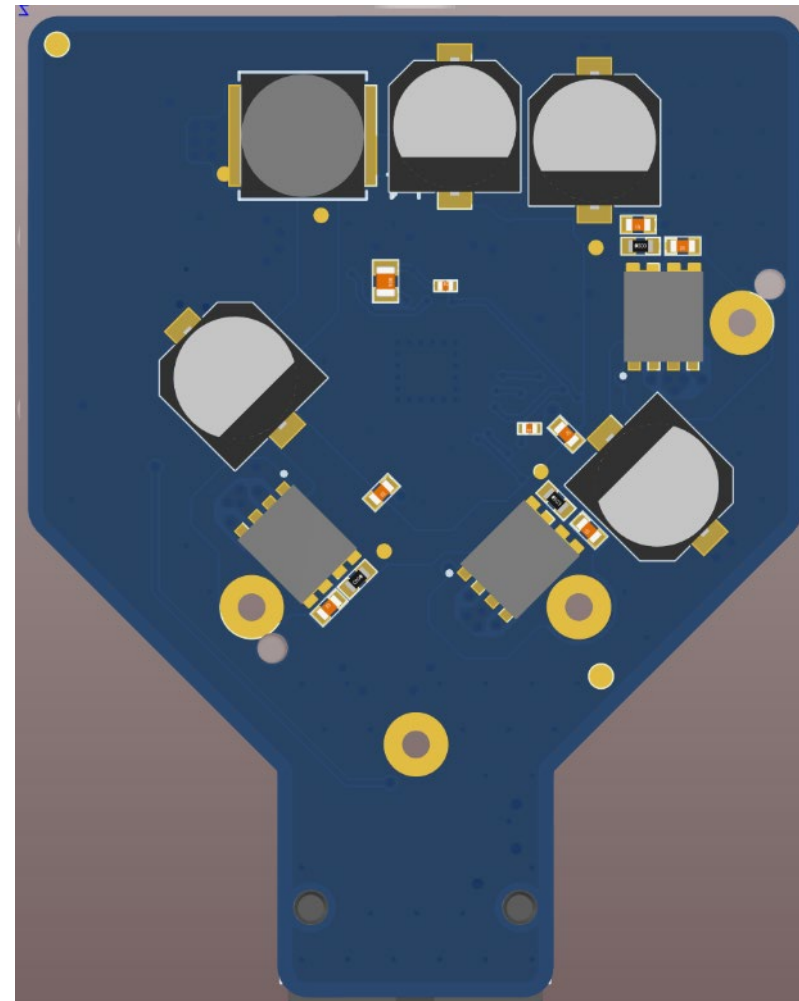
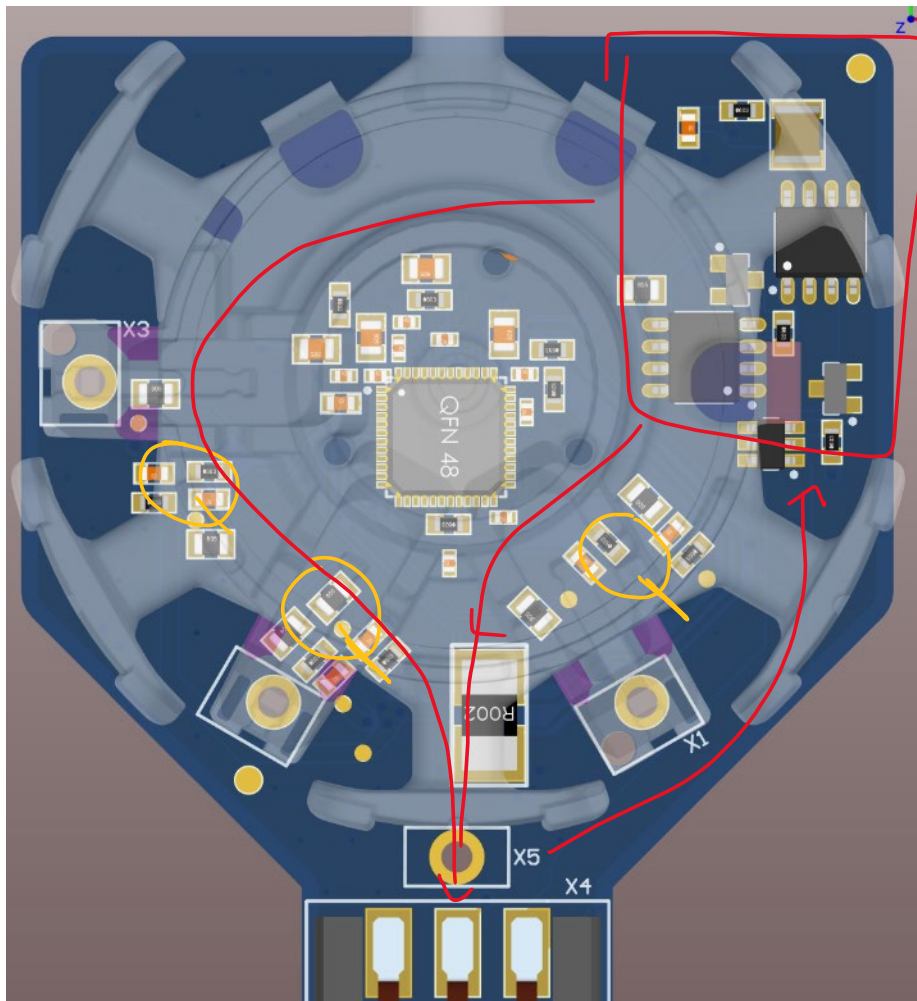

Srednji
plasti sta
GND

Preliminarne meritve

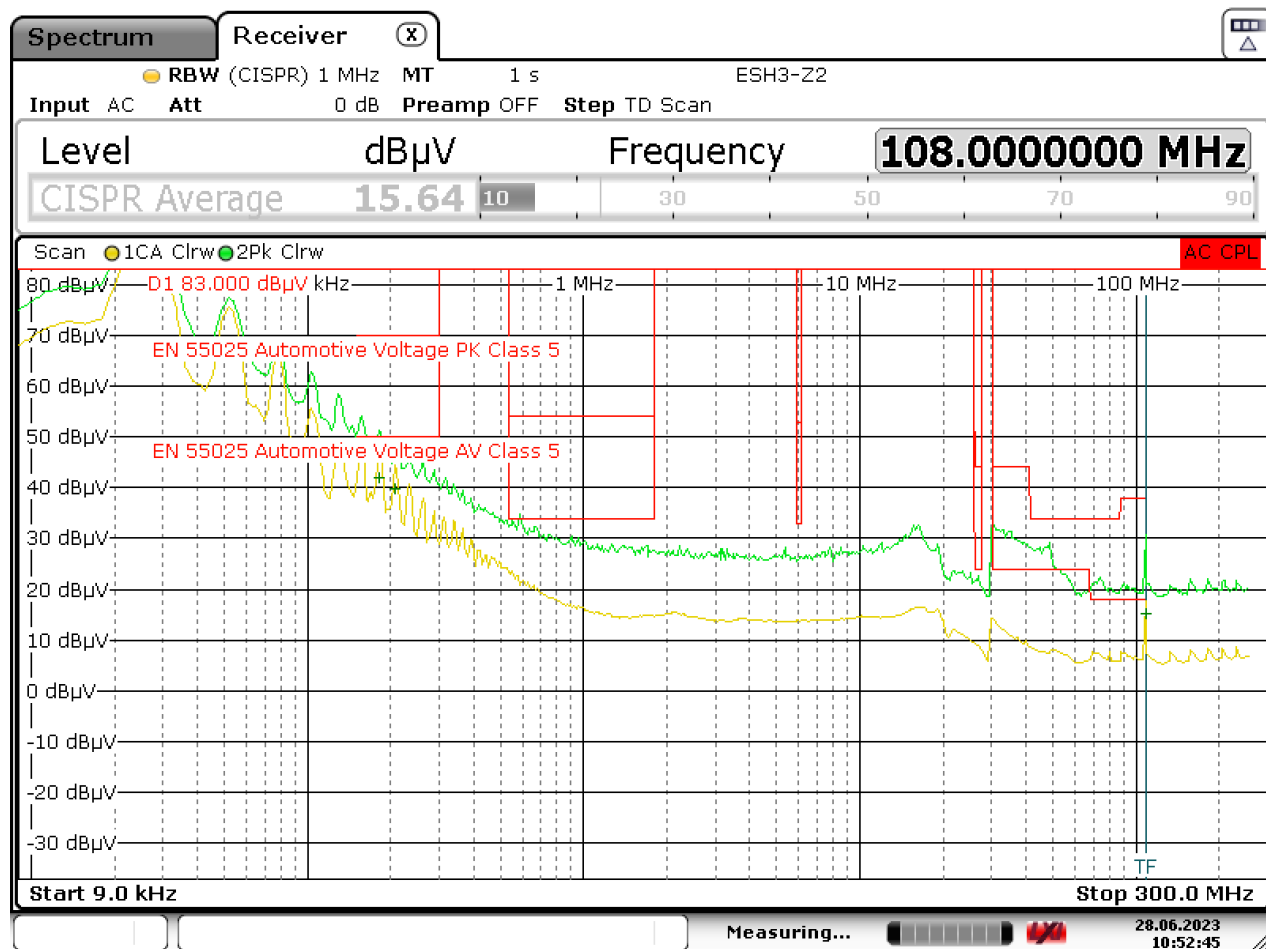

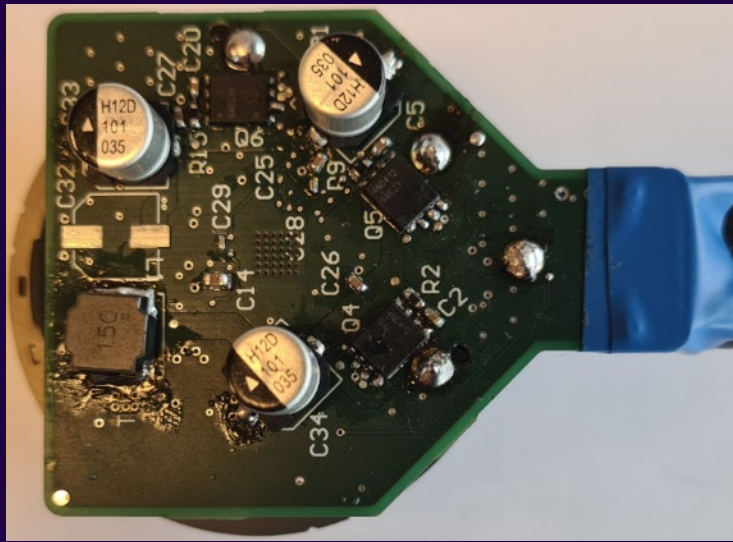

KOLEKTOR



Rezultati

Tjaž Uran Oblak

Tjaž Uran Oblak

FID1 FID2

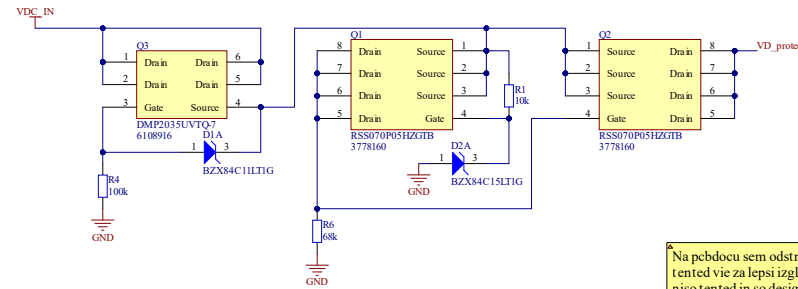

Spremenjene so bile vrednosti uporov in kondenzatorjev iz TBD na prave vrednosti na vseh 3 tranzistorskih vejah

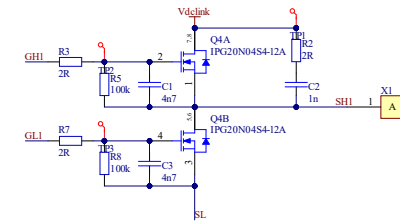

Na pcbdocu sem odstranil designatorje in naredil tented vie za lepši izgled, na izdelanem vezju niso tented in so designatorji.

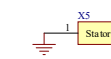
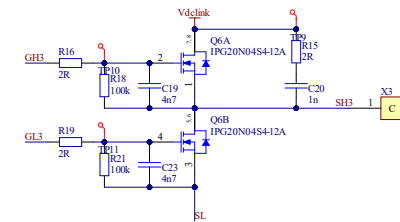
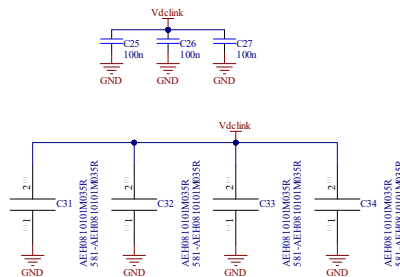
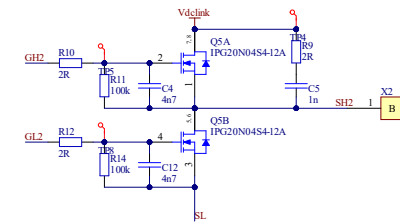
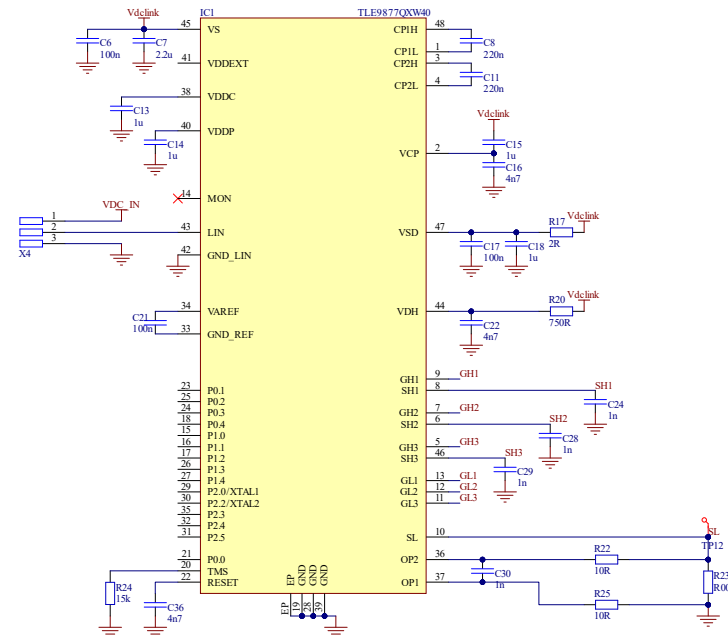
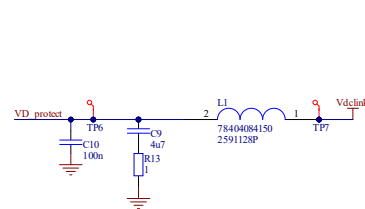

Tjaž Uran Oblak

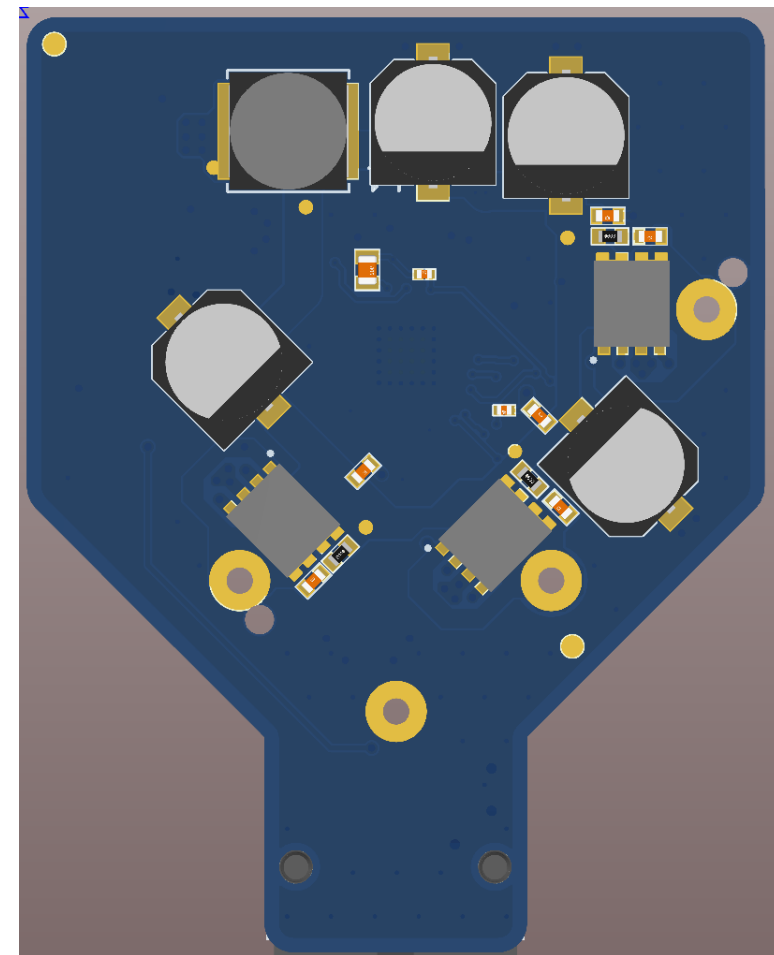
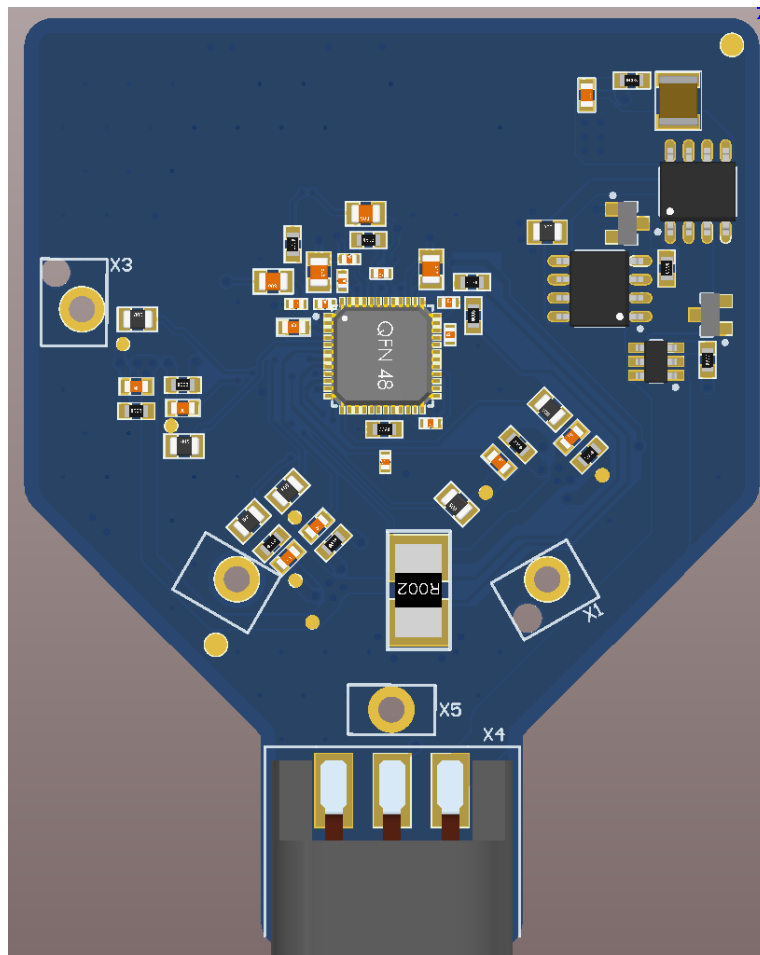

Tjaž Uran Oblak

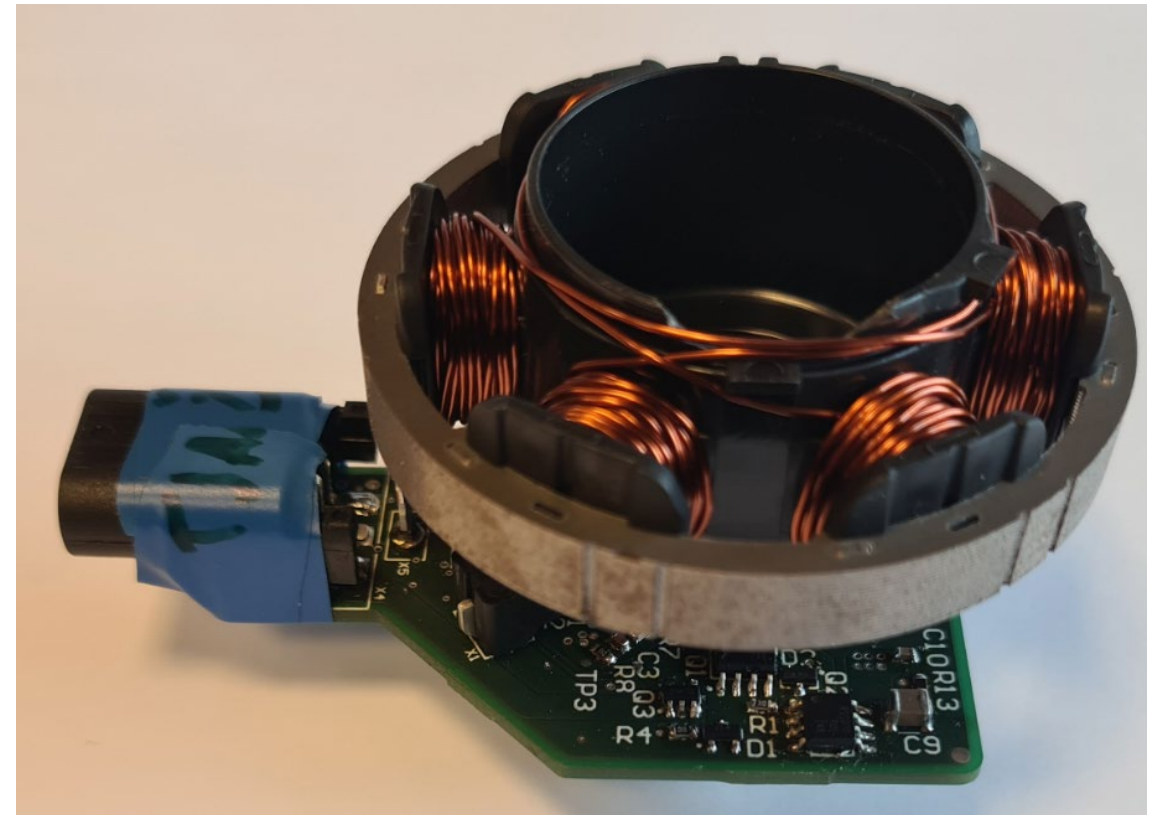
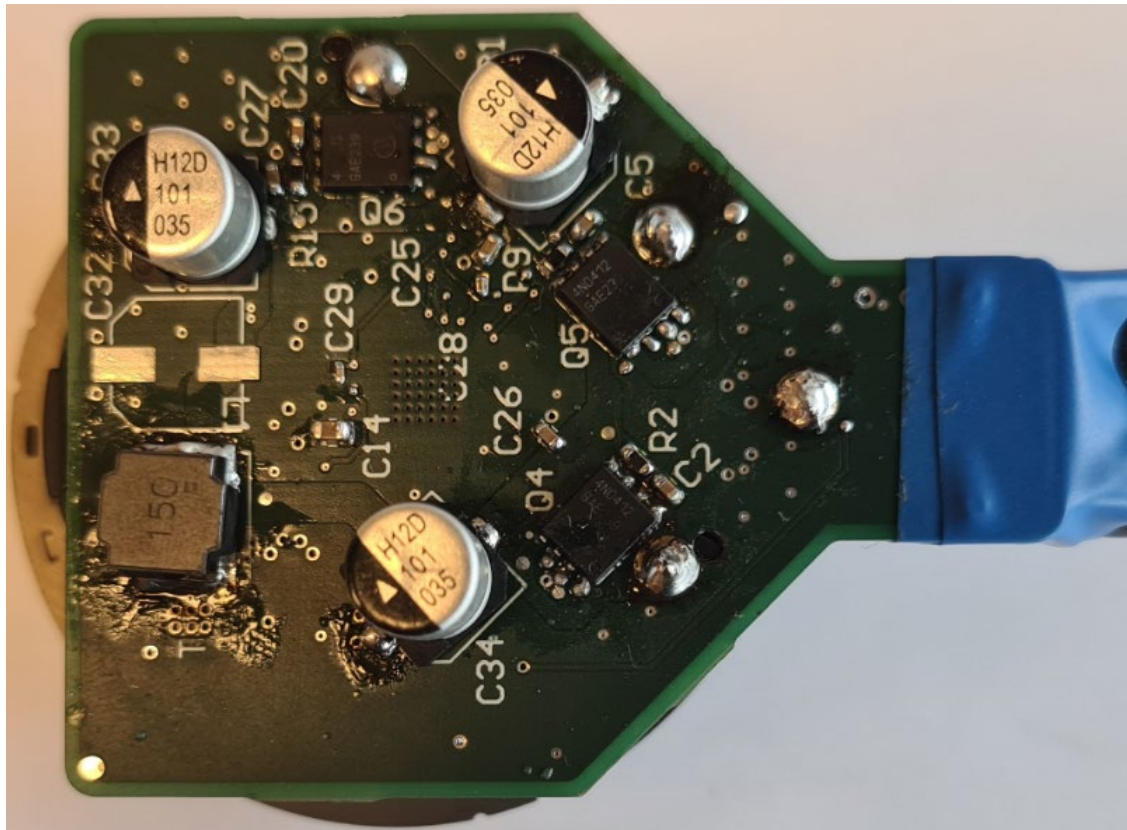

Tjaž Uran Oblak - BOM

No.	Query	Qty	Matches	Part	Part Description	Distributor/SKU	Unit Price	Line Total	Batch Total
1	IPG20N04S4-12A	3	✓	Infineon IPG20N04S412AATMA1	40V, Dual N-Ch, 12.2 mΩ max, Automotive MOSFET, dual SS08 (5x6), OptiMOS™-T2,	Farnell 3514433 Stock: 3.983	0,4770	1,4310	1.431,0000
2	RSS070P05HZGTE	2	✓	ROHM RSS070P05HZGTB	Mosfet, P-Ch, 45V, 7A, Sop Rohs Compliant: Yes Rohm RSS070P05HZGTB	DigiKey 846-RSS070P05HZGTBCT-ND Stock: 2.103 Cut Tape	0,6720	1,3440	1.343,9600
3	DMP2035UVTQ-7	1	✓	Diodes Inc. DMP2035UVTQ-7	Mosfet, P-Ch, 20V, 6A, Tsot-26 Rohs Compliant: Yes Diodes Inc. DMP2035UVTQ-7	TME DMP2035UVTQ-7 Stock: 0 ⚠	0,1300	0,1300	130,0000
4	78404084150	1	✓	Würth Elektronik 78404084150	Power Inductor, Smd, 15Uh, 3.75A Rohs Compliant: Yes Würth Elektronik 78404084150	RS 2591128P Stock: 1.000	0,333€ ⇒ 0,6542	⇒ 0,6542	⇒ 654,1961
5	CL32B475KBUYNP	1	✓	Samsung CL32B475KBUYNNE	Multilayer Ceramic Capacitor, 4.7 uF, 50 V, ± 10%, X7R, 1210 [3225 Metric]	LCSC C170099 Stock: 9.080	0,0665	0,0665	66,5000
6	CL10B104KB85PN	4	✓	Samsung CL10B104KB85PND	Multilayer Ceramic Capacitor, 0.1 uF, 50 V, ± 10%, X7R, 0603 [1608 Metric]	Newark 70AH5896 Stock: 25.662	⇒ 0,0094	⇒ 0,0375	⇒ 37,5100
7	AEH0810101M035	4	✓	AVX AEH0810101M035R	Capacitor Aluminum 100uF 35Vdc 20% Radial Can Cylindrical Can 220mA 2000 hr	TTI AEH0810101M035R Stock: 0 ⚠ Tape & Reel	⇒ 0,1932	⇒ 0,7727	⇒ 772,7060
8	BZX84C11LT1G	1	📄	onsemi BZX84C11LT1G	BZX84C11LT1 Series 225 mW 10 mA 11 V SMT Zener Voltage Regulator - SOT-23-3	Rochester Electronics BZX84C11LT1G Stock: 433.338	⇒ 0,0209	⇒ 0,0209	⇒ 20,9118
9	BZX84C15LT1G	1	📄	onsemi BZX84C15LT1G	DIODE ZENER 15V 225MW SOT23-3 / Zener Diode Single 15V 5% 30Ohm 300mW 3-Pin	Newark 72T0940 Stock: 48.997	⇒ 0,0122	⇒ 0,0122	⇒ 12,1907

Tekmovalc	cena tranzistorjev	Cena kondenzatorjev	Cena dušilk	Cena diod	Skupaj
Tjaž Uran Oblak	2,90 €	0,88 €	0,33 €	0,03 €	4,15 €

Tekmovalc	kvalifikacija	temp. območje	ostale zahteve	Cena komponent	Točke
Tjaž Uran Oblak	3	3	3	4,15 €	-11,75

Tjaž Uran Oblak - delovanje

- Izkoristek 83,5 %
- **Prenihaj 6,2 V**
- Padec napetosti 0,192 V
- Tok nasprotne polaritete 0,1 mA

Tekmovalec	Osnovna	Izkoristek	Polariteta	Padec r	Prenihaj	Točke
Tjaž Uran Oblak	12	7	5	5	0	29

Tjaž Uran Oblak - CE

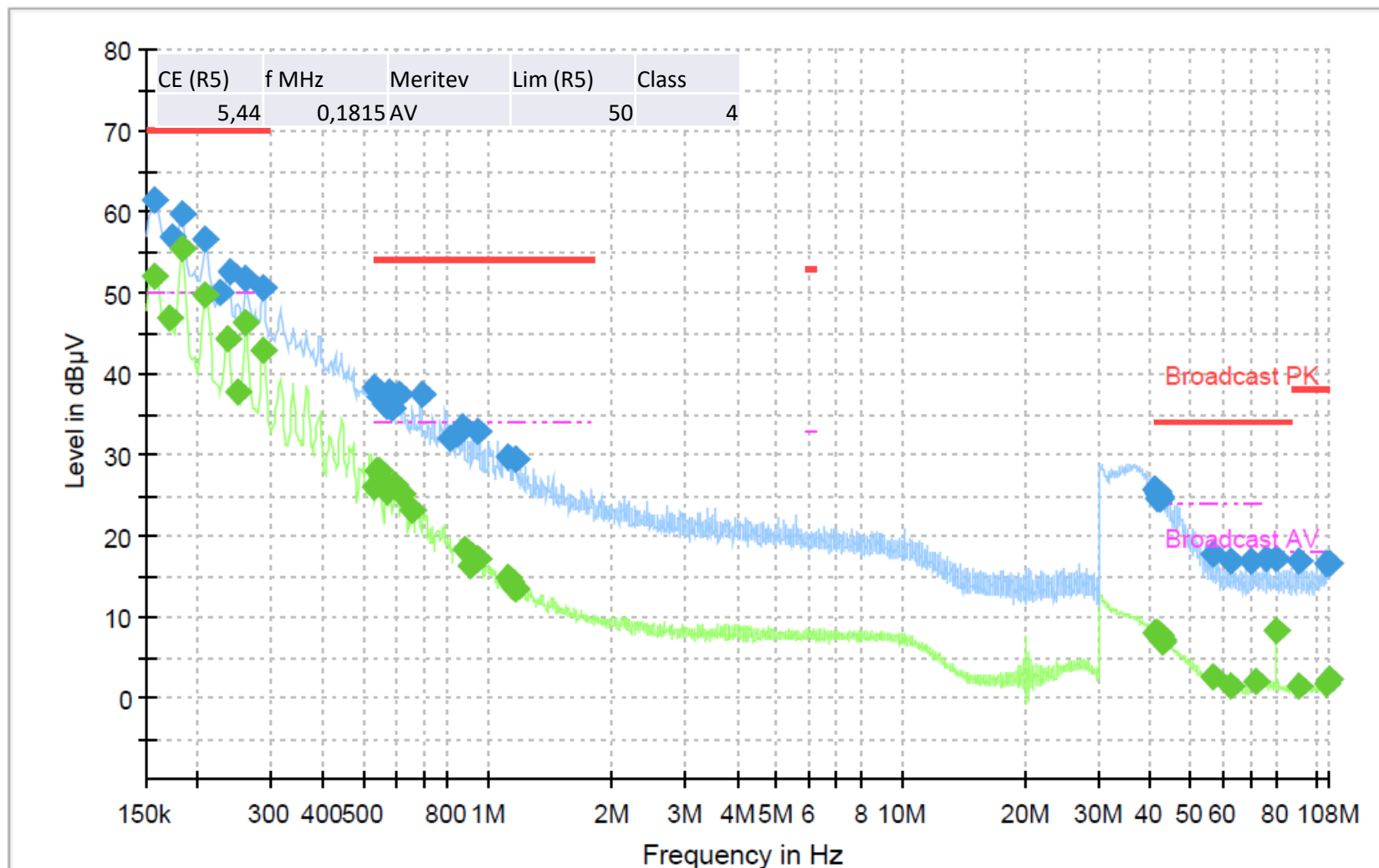

Tjaž Uran Oblak - VW

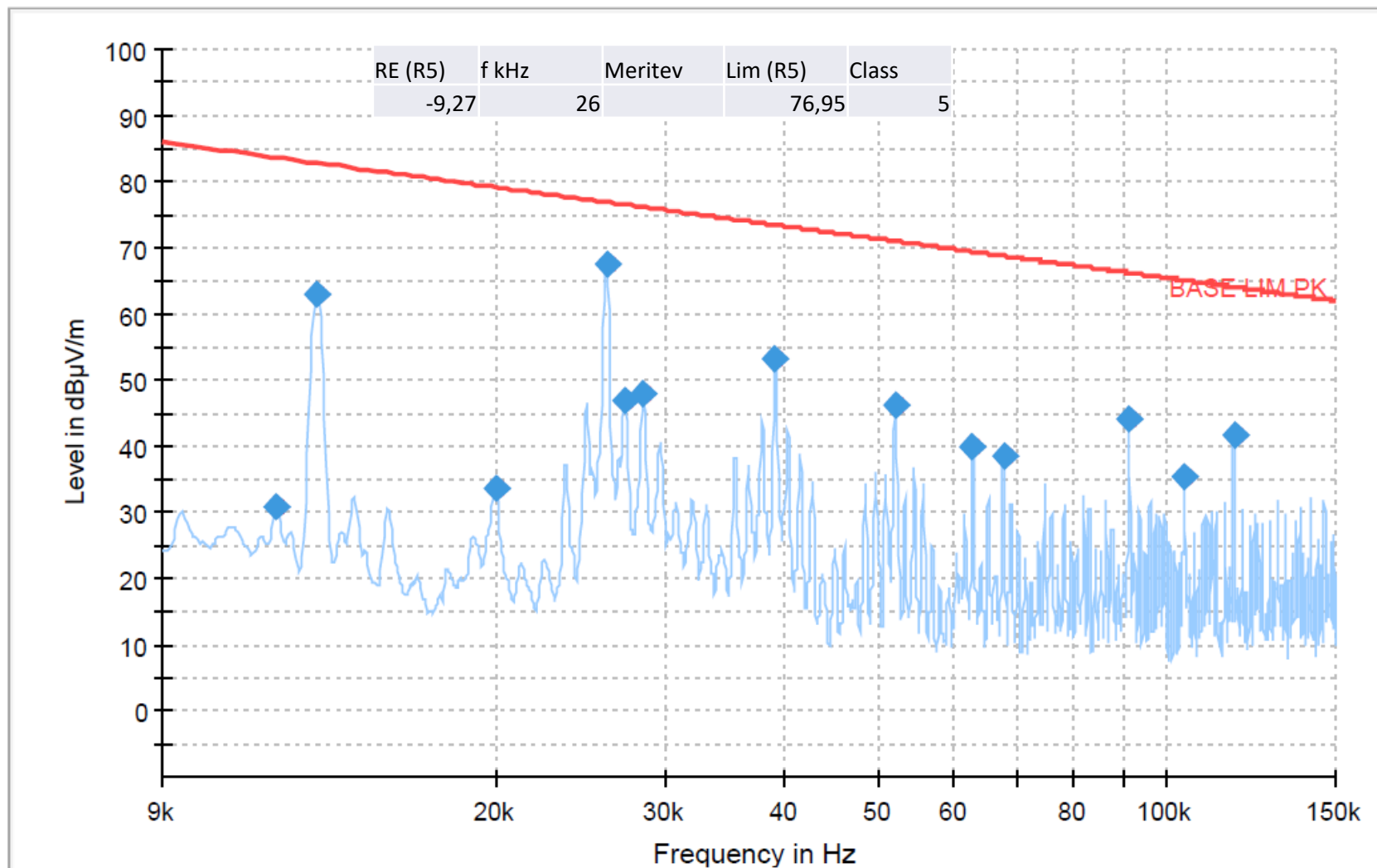

Tjaž Uran Oblak - RE

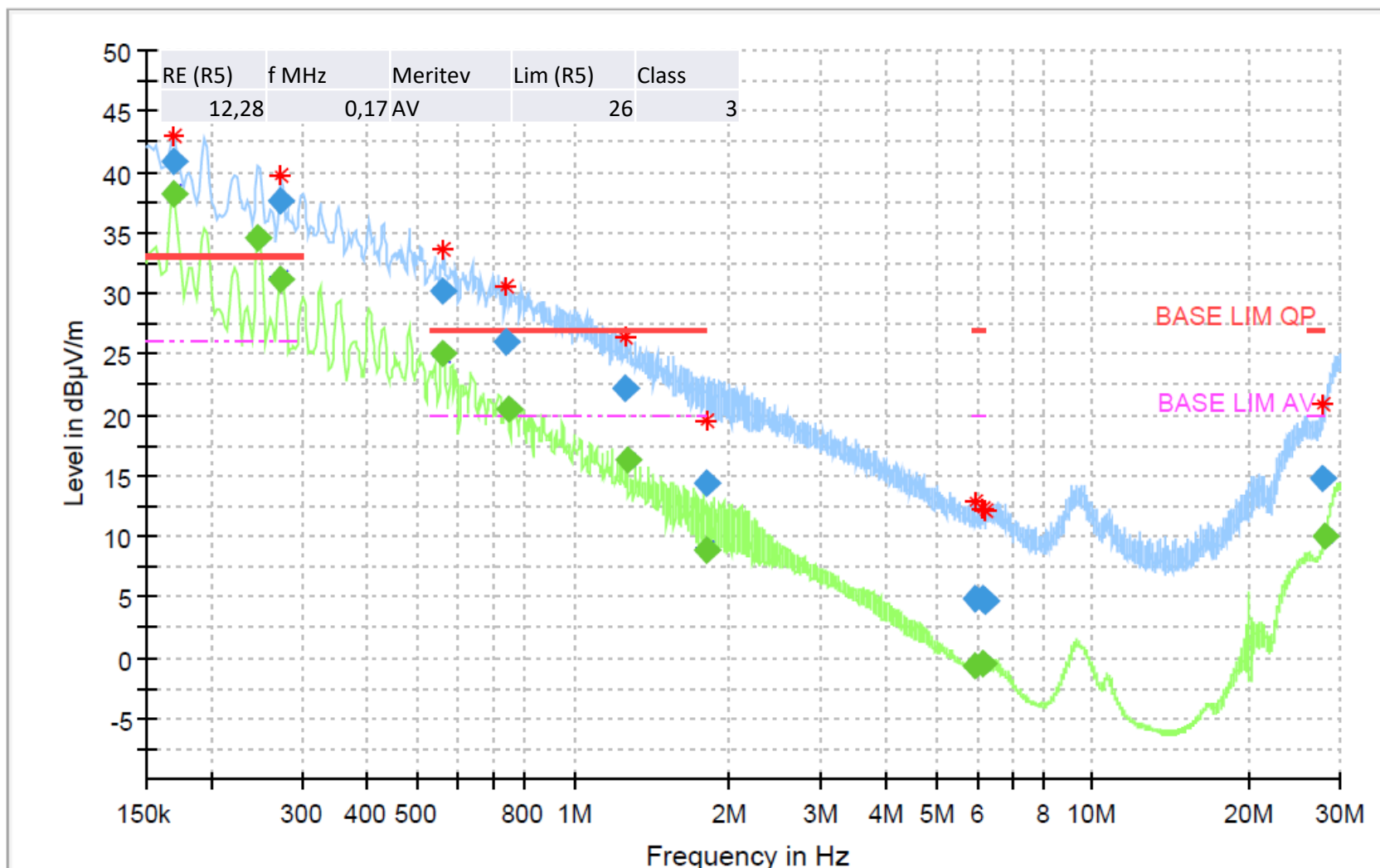

Tjaž Uran Oblak - RE

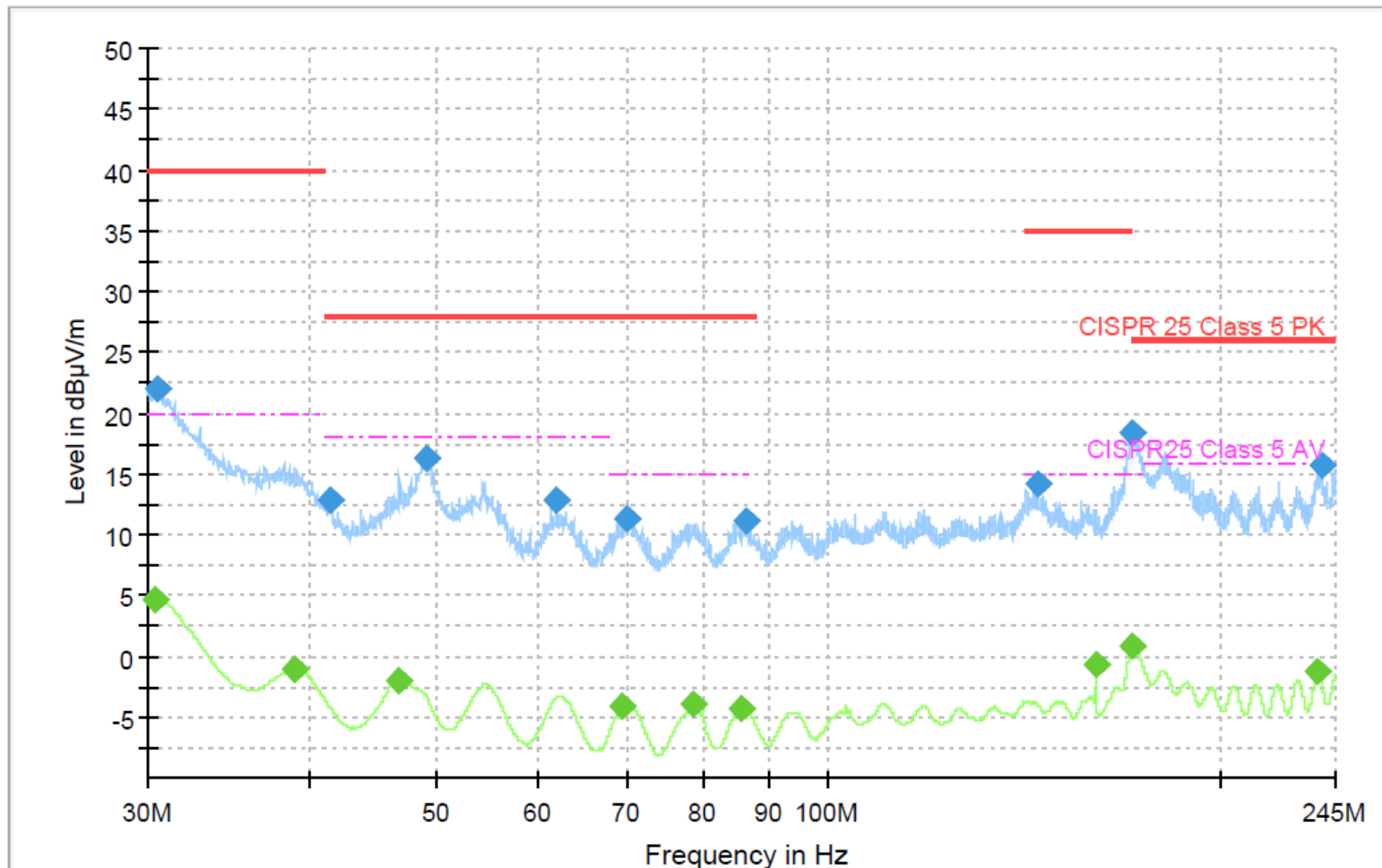

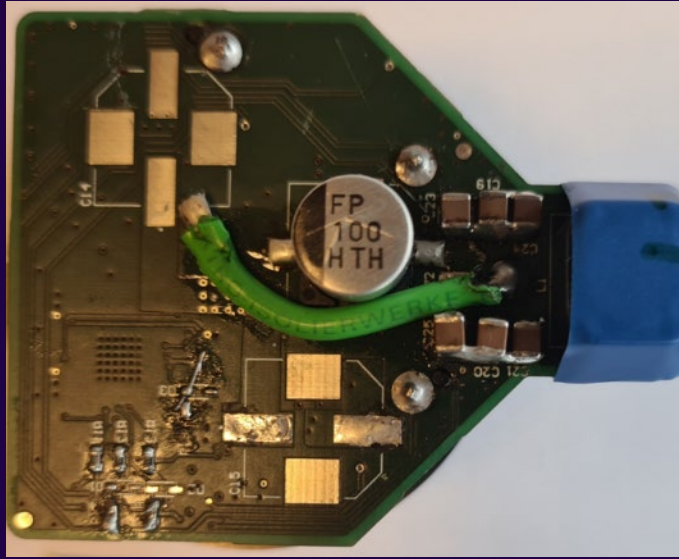

KOLEKTOR



Predstavitev

Žan Hedžet Kostanjšek

Shema

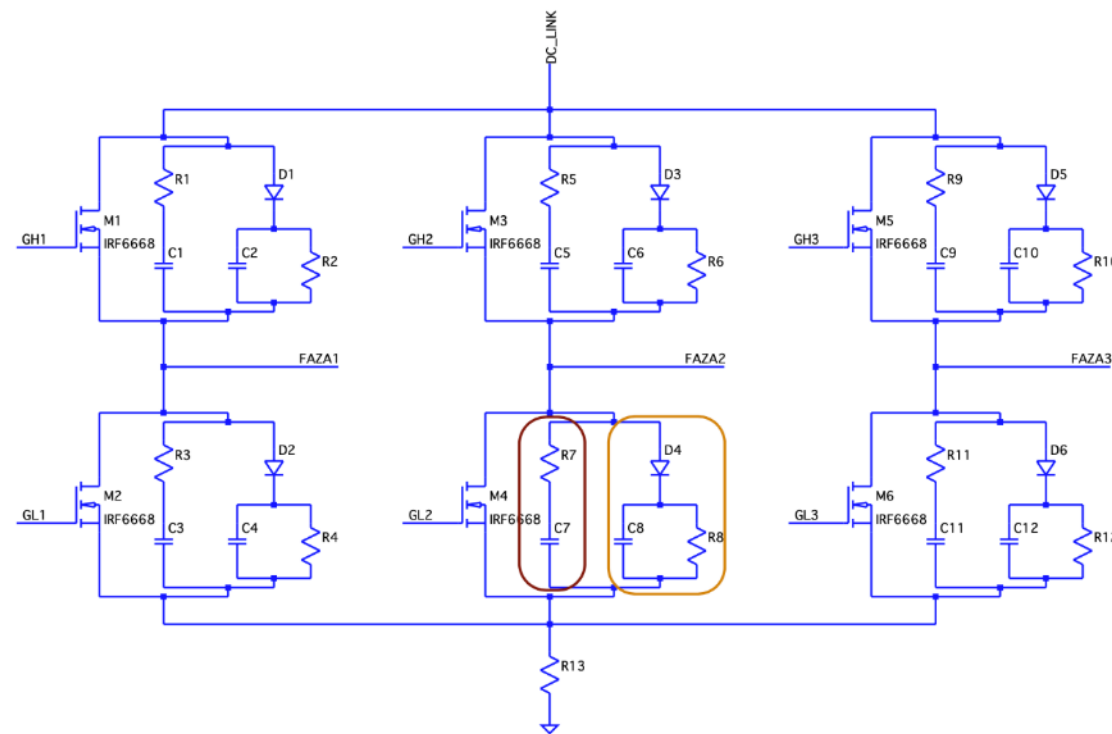

Shema

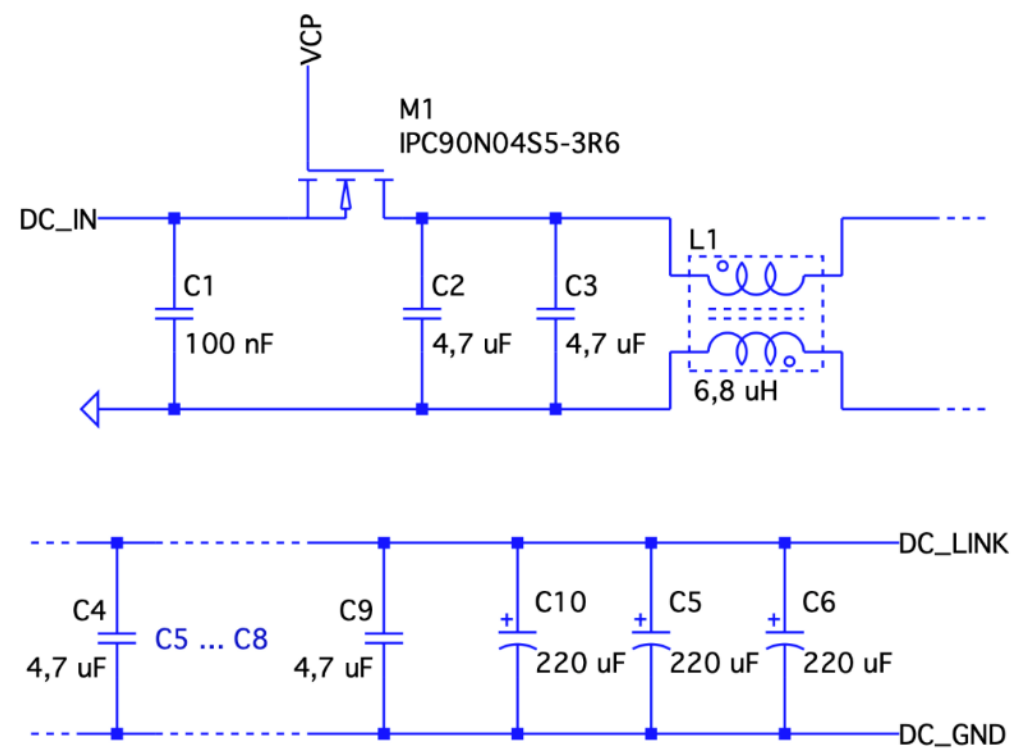

Načrt tiskanega vezja

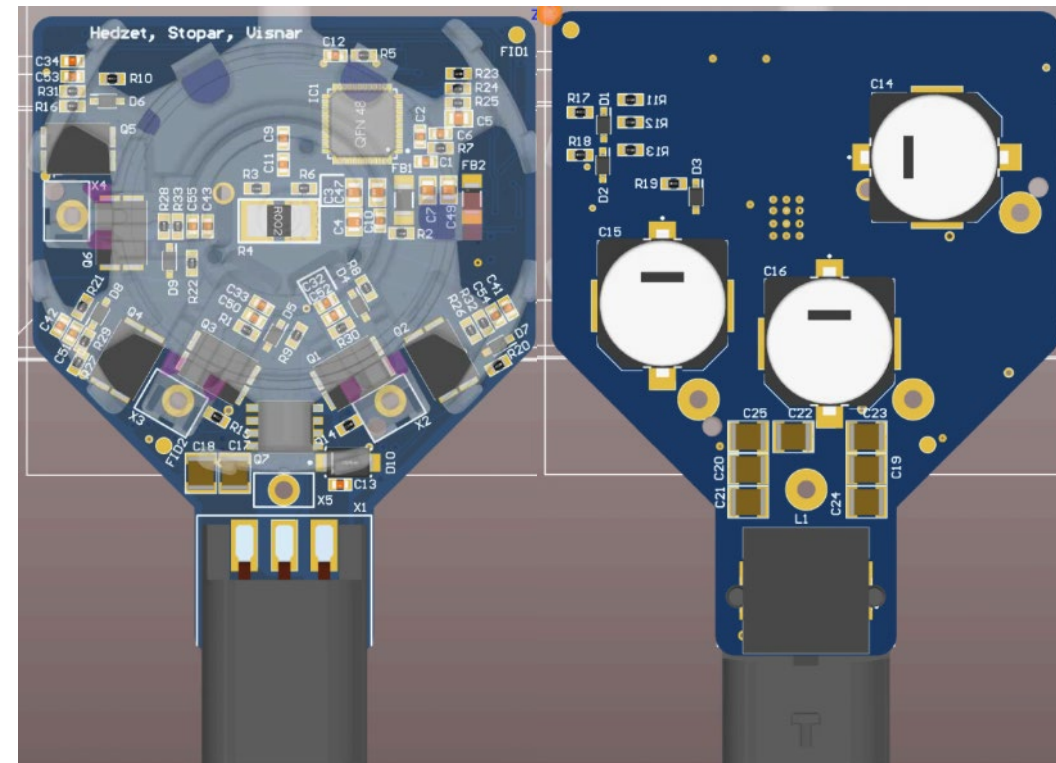
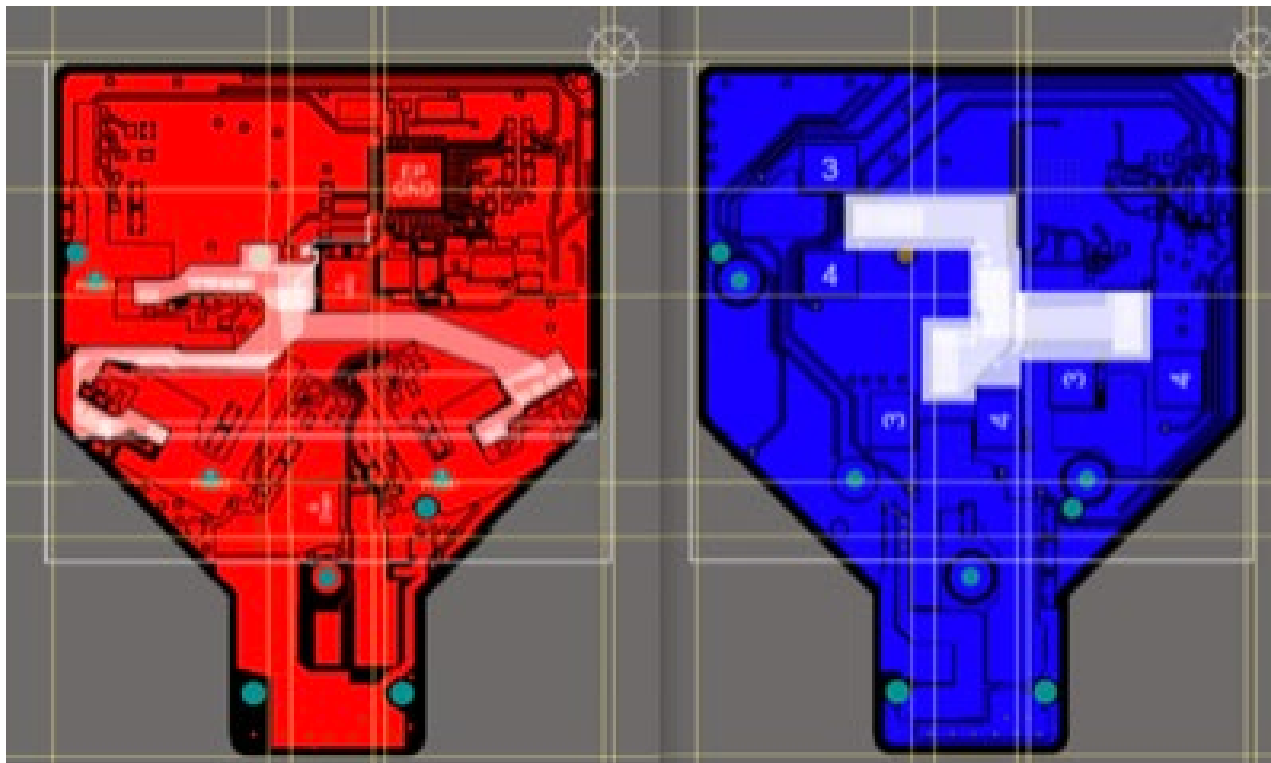

Preliminarne meritve

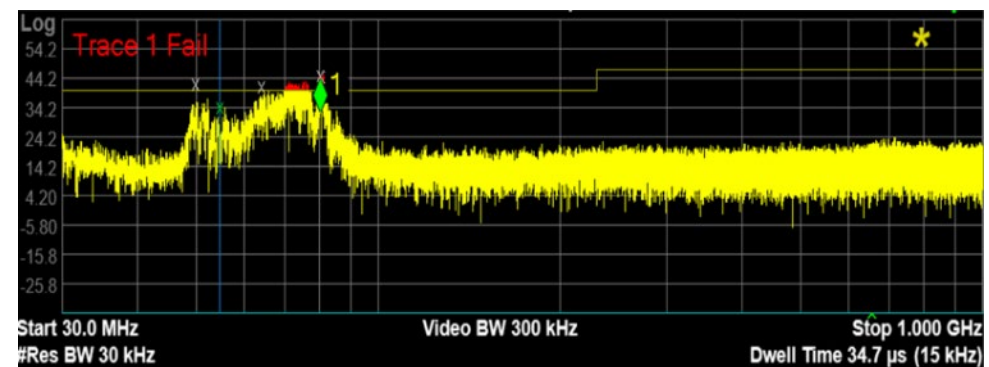
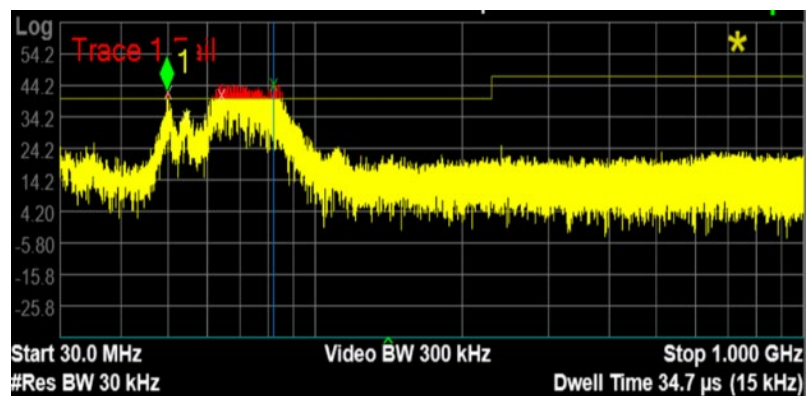

Preliminarne meritve

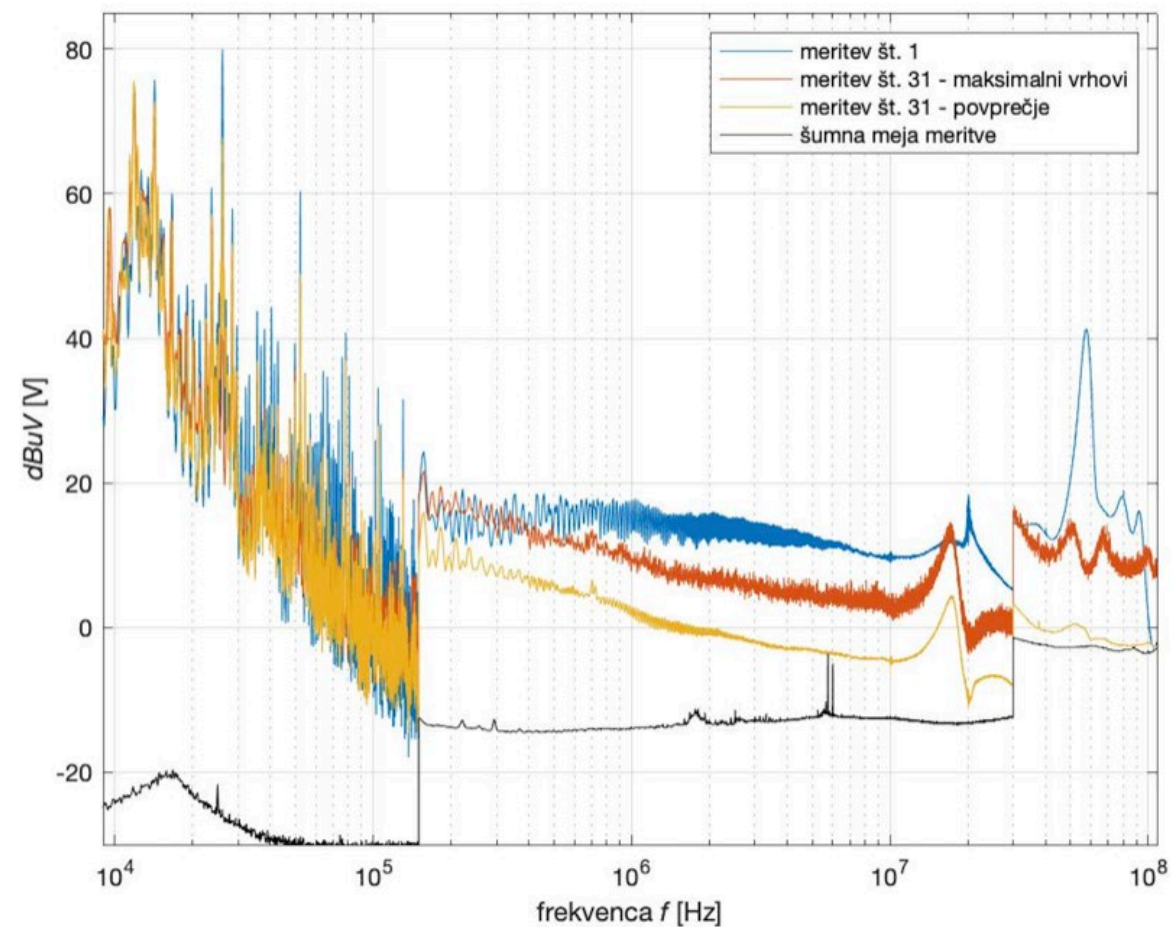
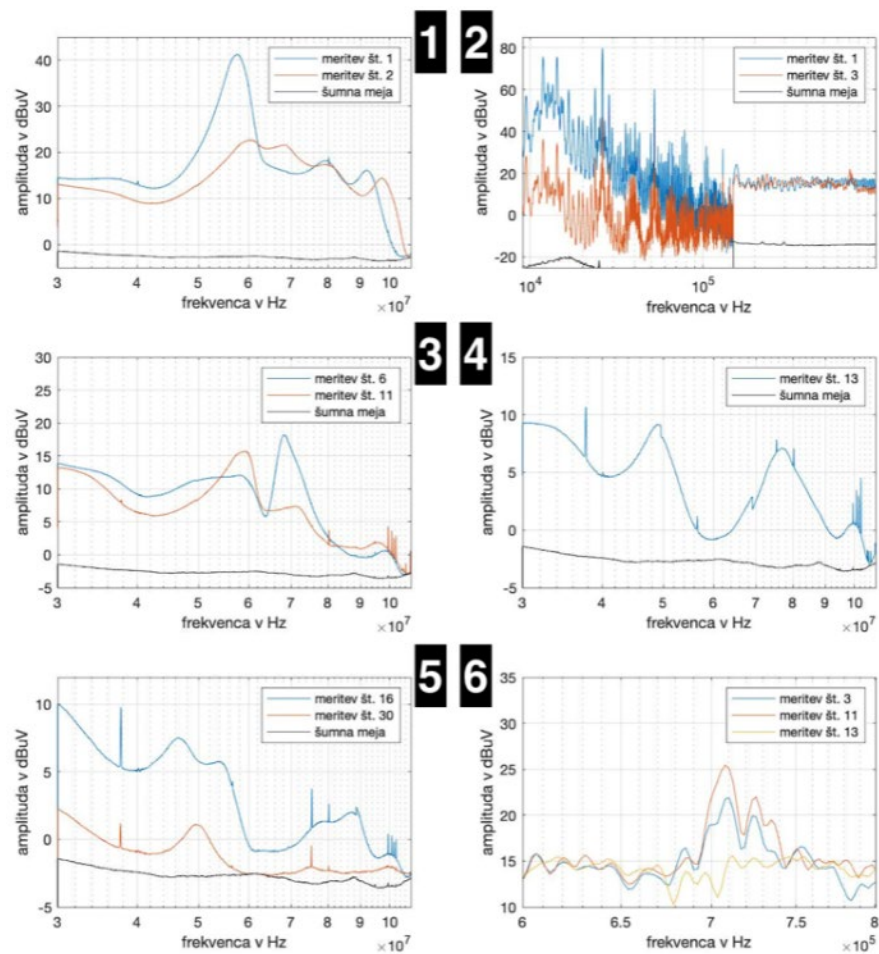

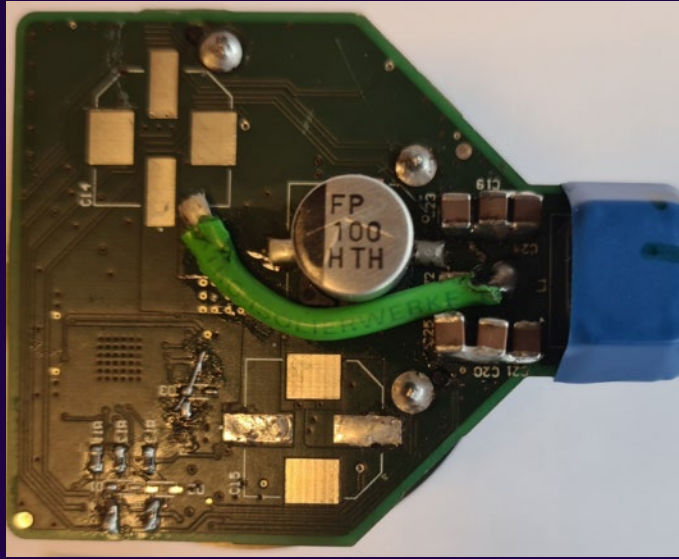

KOLEKTOR



Rezultati

Žan Hedžet Kostanjšek

Žan Hedžet Kostanjšek

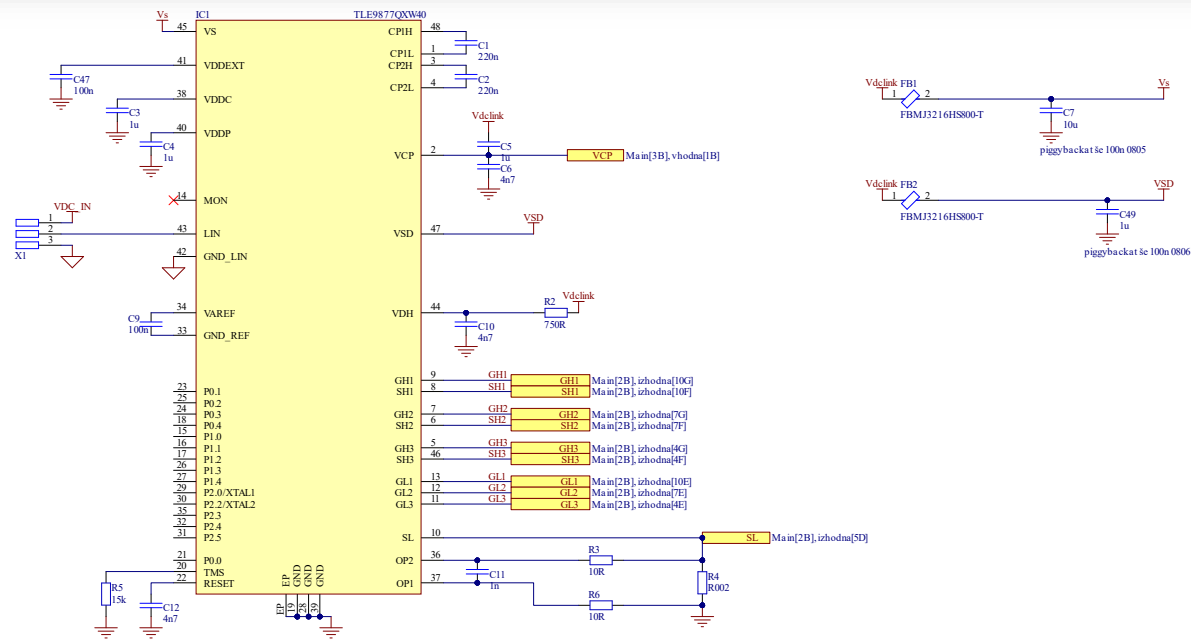
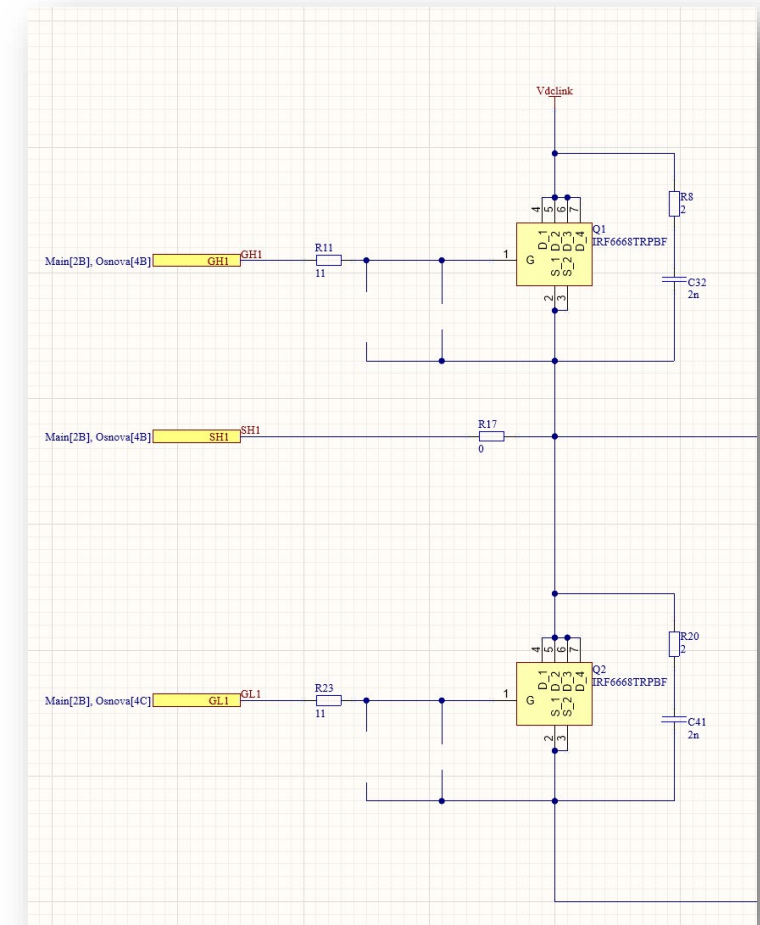
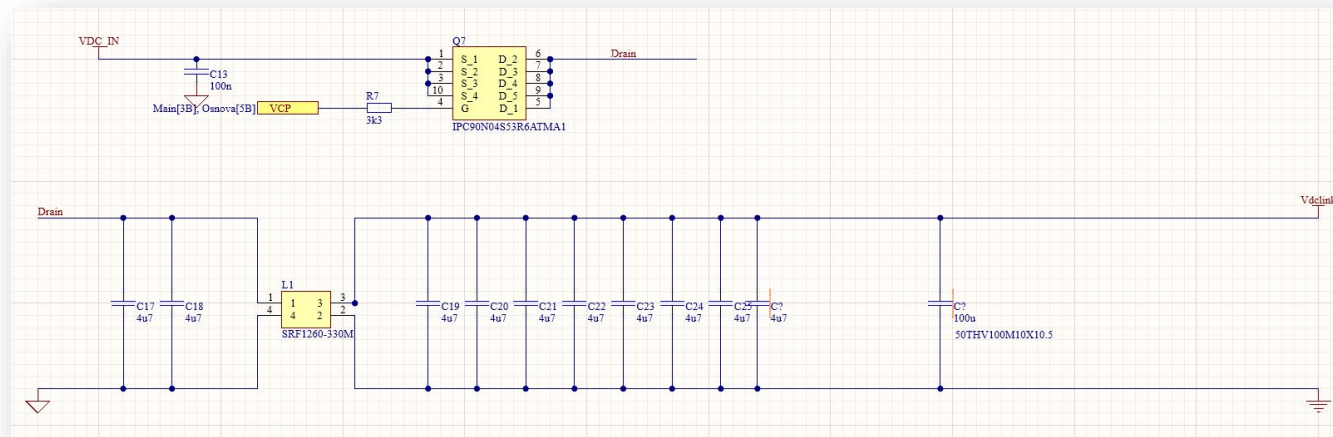

Žan Hedžet Kostanjšek

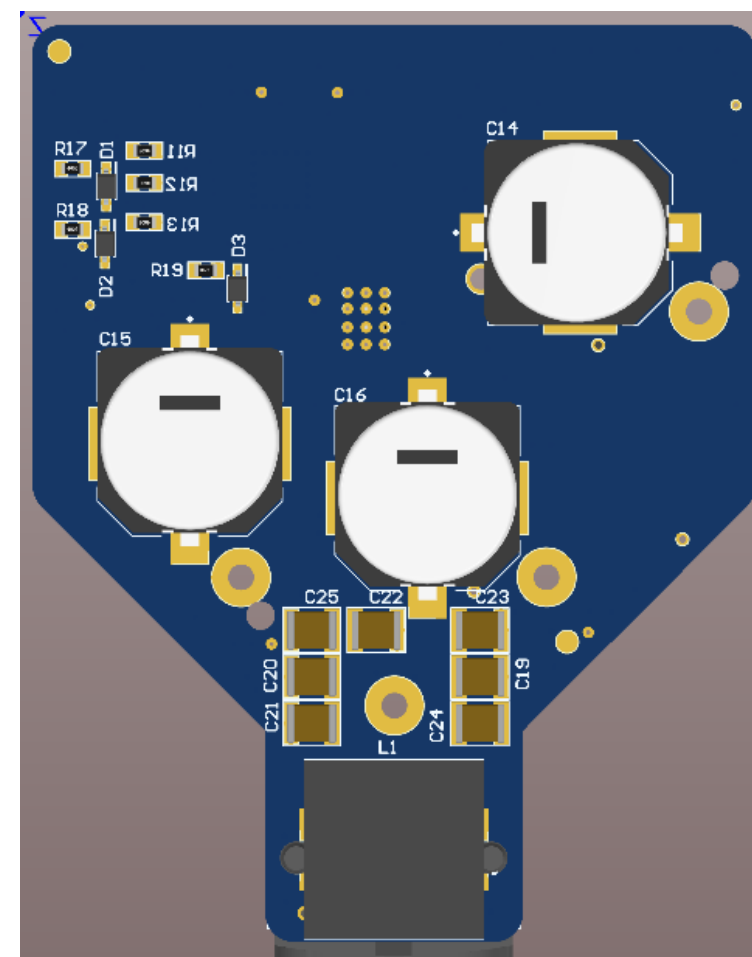
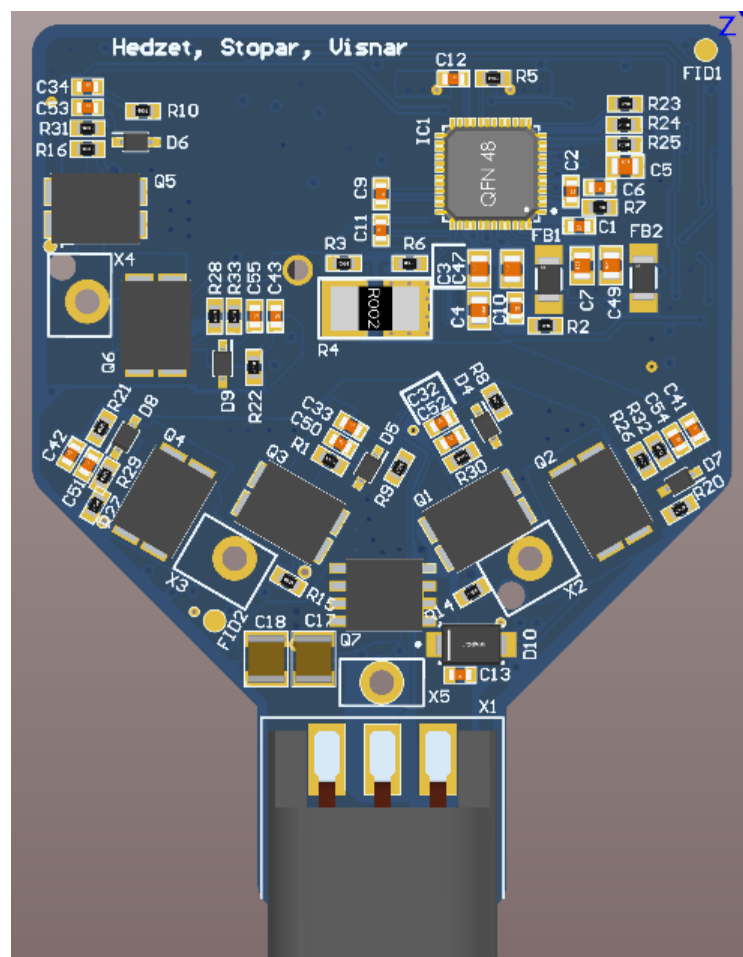

Žan Hedžet Kostanjšek

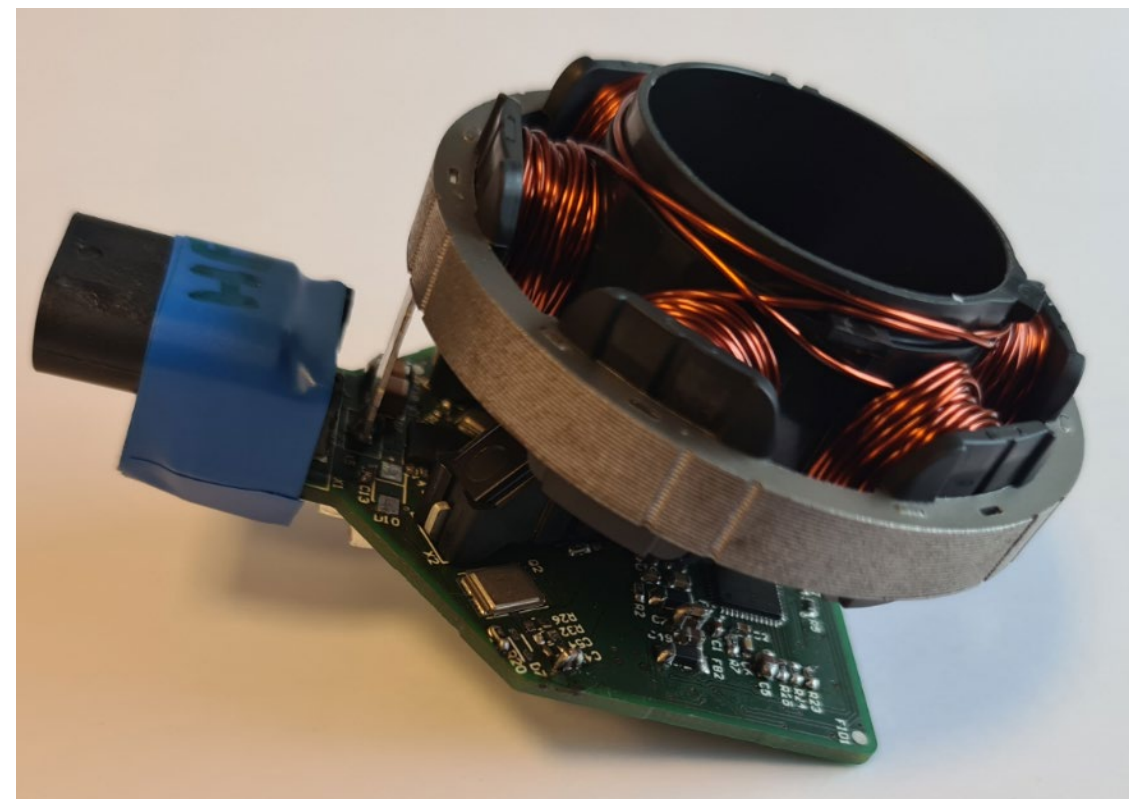
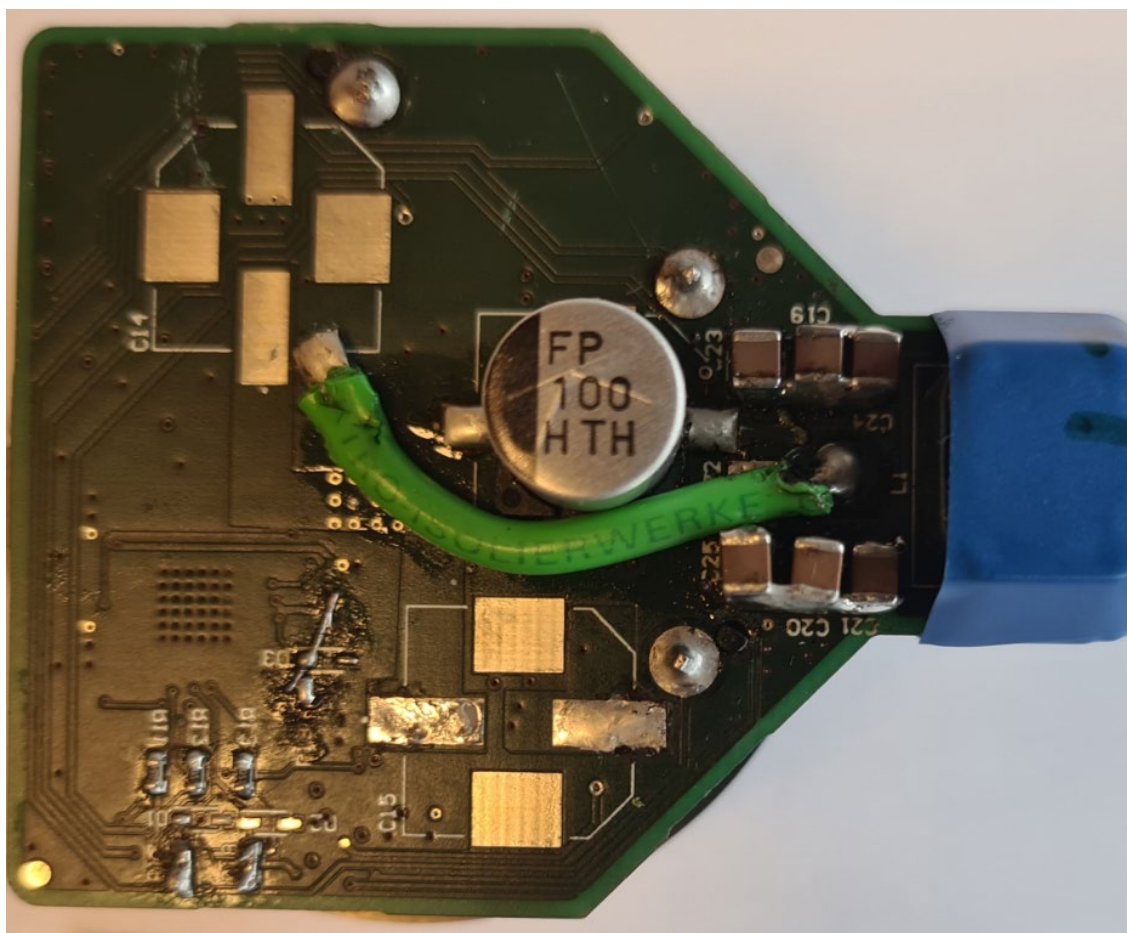

Žan Hedžet Kostanjšek - BOM

No.	Query	Qty	Matches	Part	Part Description	Distributor/SKU	Unit Price	Line Total	Batch Total	Notes
1	IRF6668TRPBF	6		Infineon IRF6668TRPBF	Single N-Channel 80 V 15 mOhm 31 nC HEXFET® Power Mosfet - DirectFET®	Verical IRF6668TRPBF Stock: 77	≈ 0,6849	≈ 4,1096	≈ 4.109,5956	Ni automotive
2	GRM319R61H475t	10		Murata GRM319R61H475KA12D	Multilayer Ceramic Capacitor, 4.7 uF, 50 V, ± 10%, X5R, 1206 [3216 Metric]	TTI GRM319R61H475KA12D Stock: 28.000 Tape & Reel	≈ 0,0366	≈ 0,3657	≈ 365,7225	ni 125 °C
3	SRF1260-330M	1		Bourms SRF1260-330M	Ind Power Shielded Wirewound 33uH/132uH 20% 100KHz Ferrite 3.28A/1.64A T/R	Verical SRF1260-330M Stock: 400	≈ 0,4702	≈ 0,4702	≈ 470,1878	
4	IPC90N04S53R6A	1		Infineon IPC90N04S53R6ATMA1	Mosfet, Aec-Q101, N-Ch, 40V, 90A, Tdson Rohs Compliant: Yes Infineon	RS 2207402P Stock: 10.005	≈ 0,6691	≈ 0,6691	≈ 669,1164	
5	FBMJ3216HS800-T	2		Taiyo Yuden FBMJ3216HS800-T	Ferrite Beads Power Chip 80Ohm 25% 100MHz 4A 0.01Ohm DCR 1206 Automotive	LCSC C92887 Stock: 3.920	0,0351	0,0702	70,2000	
6	50THV100M10X10	1		Rubycon 50THV100M10X10.5	Radial Can - SMD ALUMINUM ELECTROLYTIC CAPACITOR THV 50V 100muF ±20%	element14 APAC 2102438 Stock: 485	≈ 0,2918	≈ 0,2918	≈ 291,7811	

Tekmovalc	cena tranzistorjev	Cena kondenzatorjev	Cena dušilk	Cena diod	Skupaj
Žan Hedžet Kostanjšek	4,78 €	0,66 €	0,54 €	- €	5,98 €

Tekmovalc	kvalifikacija	temp. območje	ostale zahteve	Cena komponent	Točke
Žan Hedžet Kostanjšek	0	0	3	5,98 €	-26,9

Žan Hedžet Kostanjšek - delovanje

- Izkoristek 84,81 %
- Prenihaj 3,2 V
- Padec napetosti 0,13 V
- Tok nasprotne polaritete 1 A

Tekmovalec	Osnovna	Izkoristek	Polariteta	Padec r	Prenihaj	Točke
Žan Hedžet Kostanjšek	12	10	0	5	0	27

Žan Hedžet Kostanjšek - CE

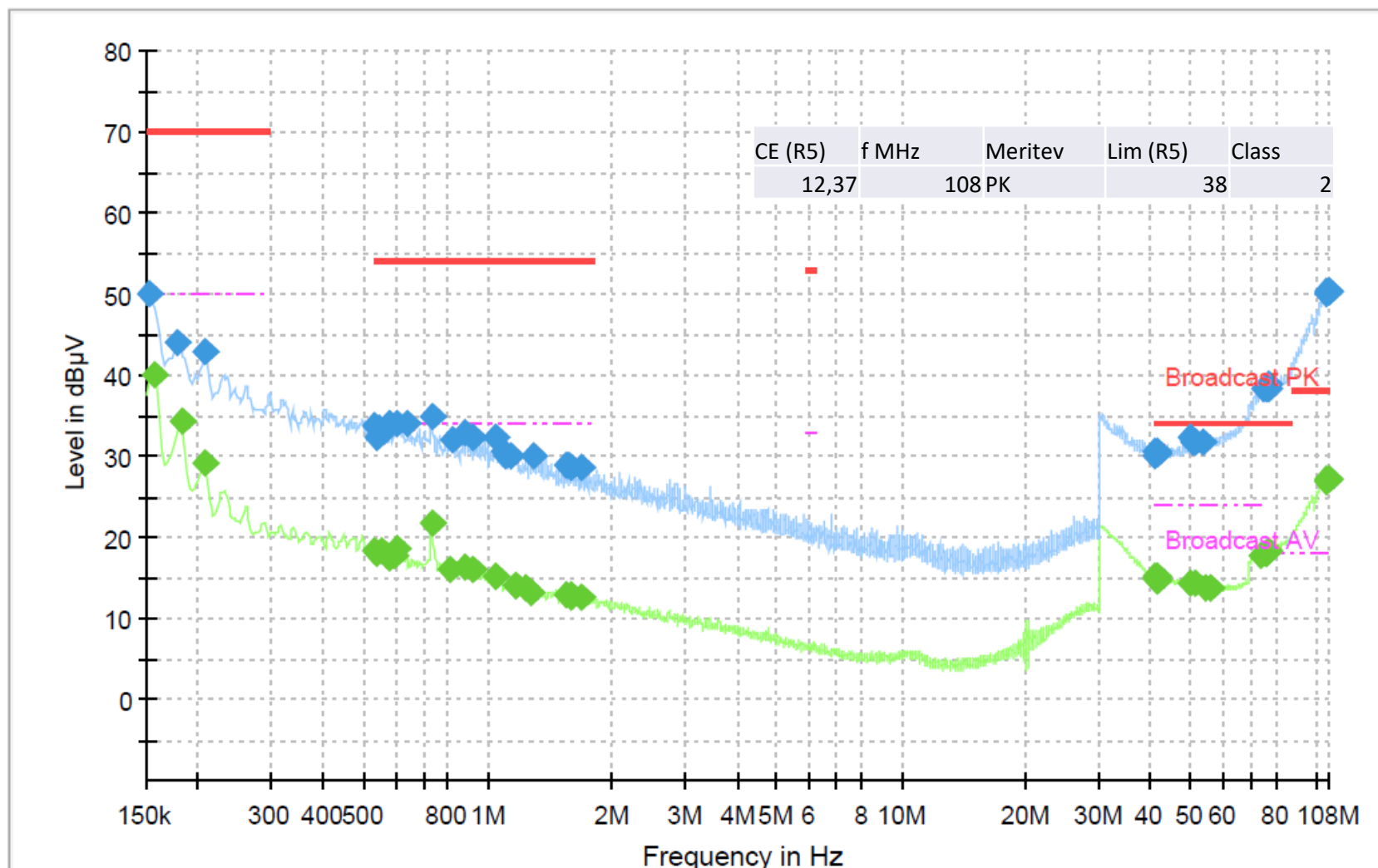

Žan Hedžet Kostanjšek - VW

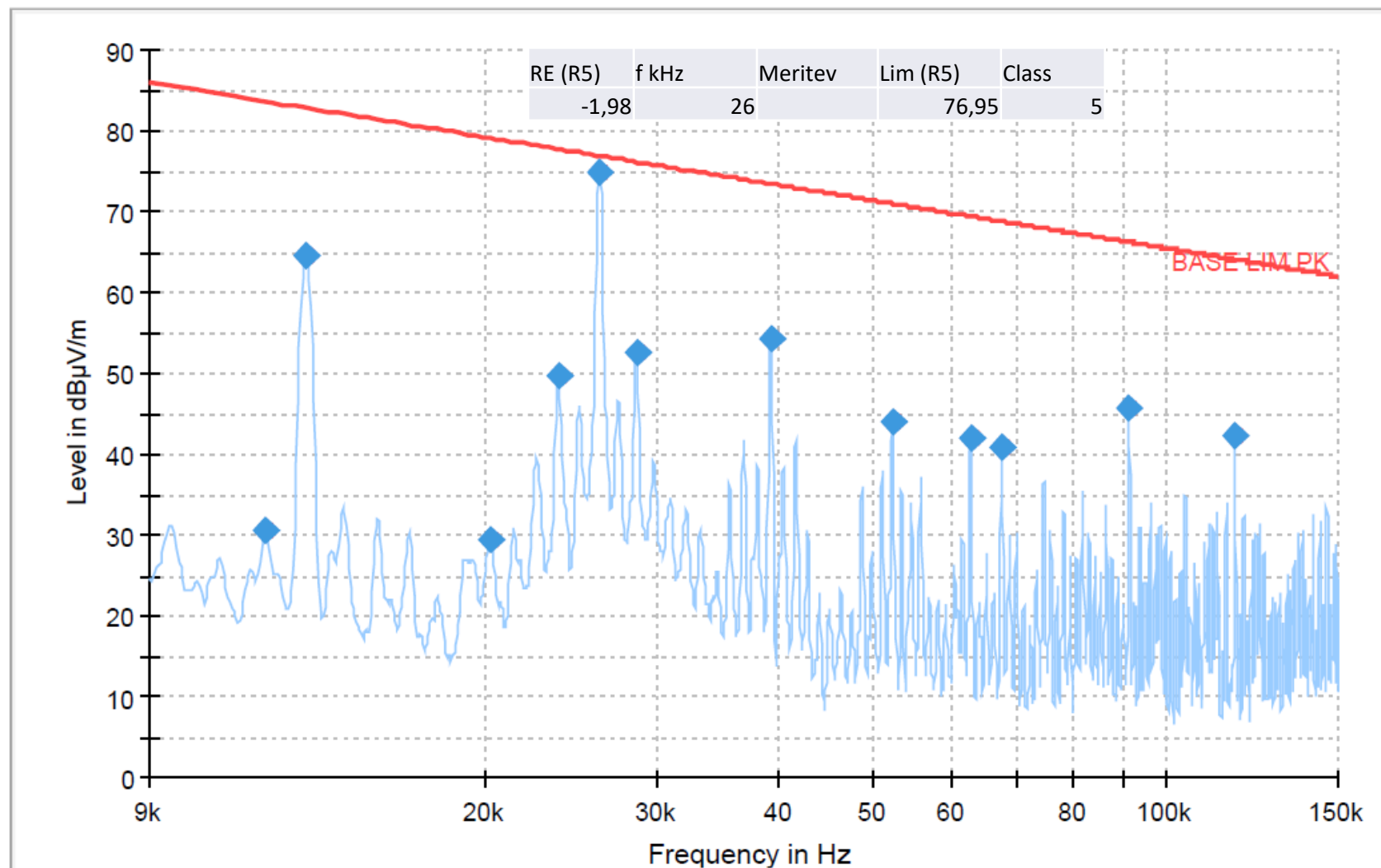

Žan Hedžet Kostanjšek - RE

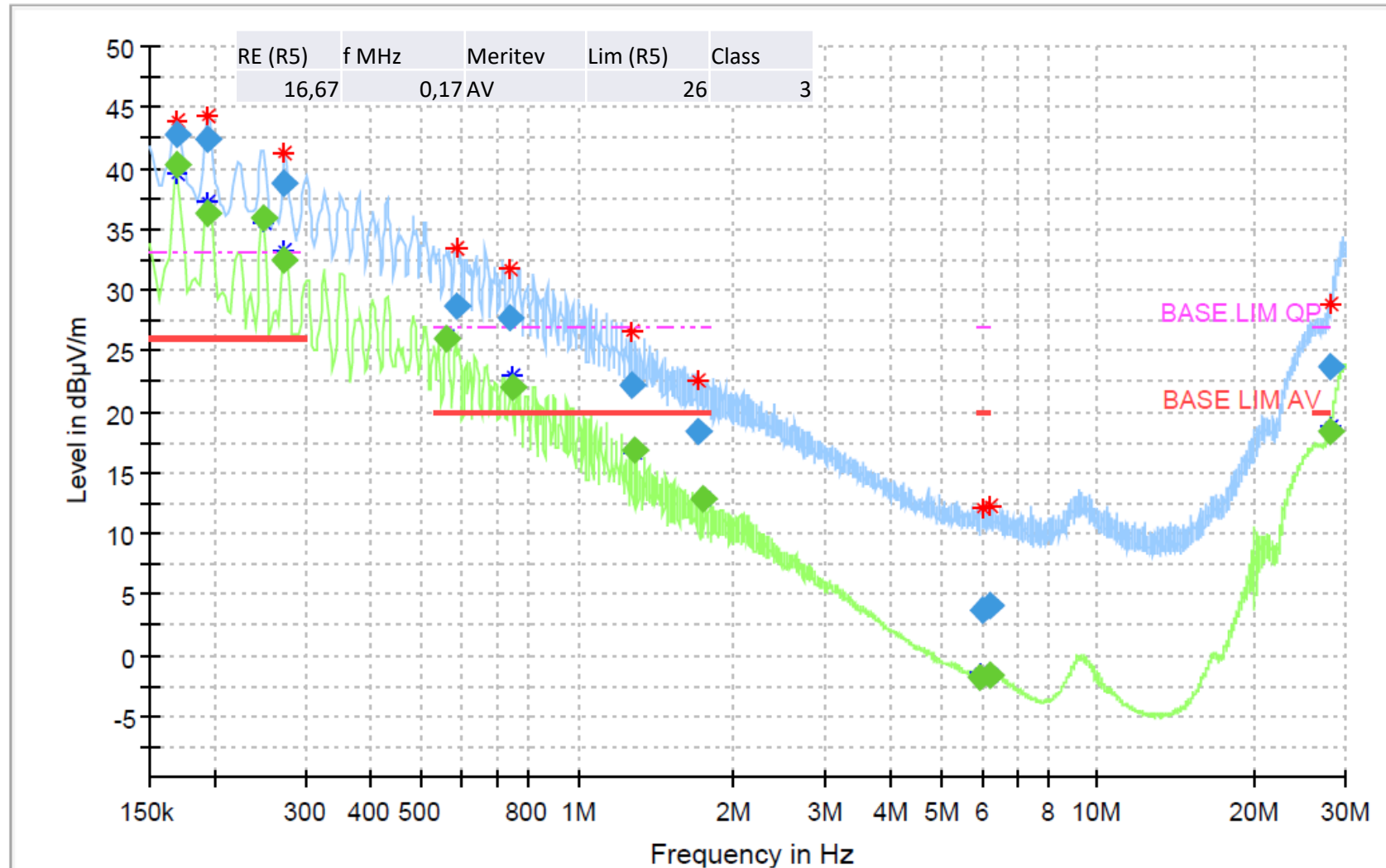

Žan Hedžet Kostanjšek - RE

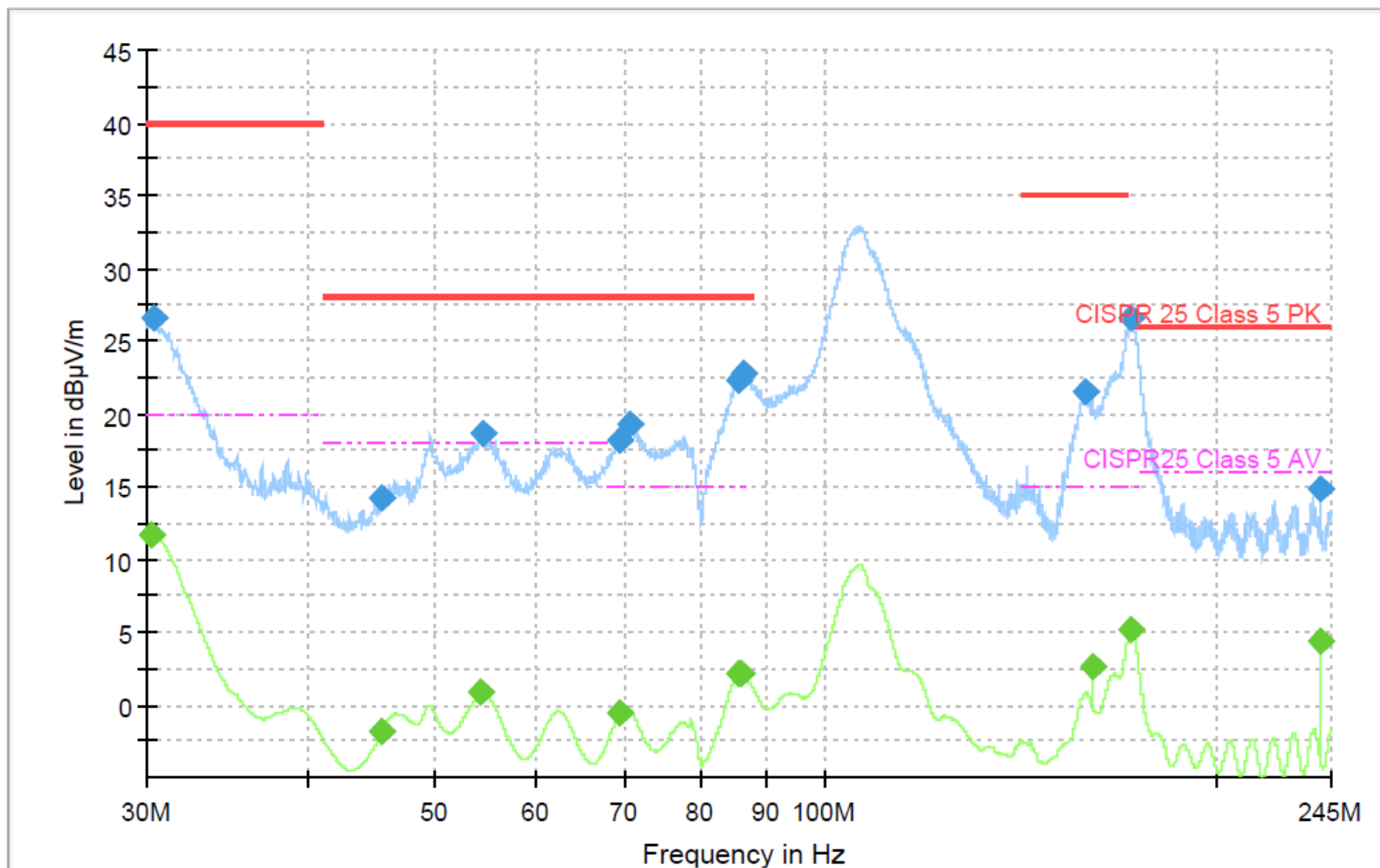

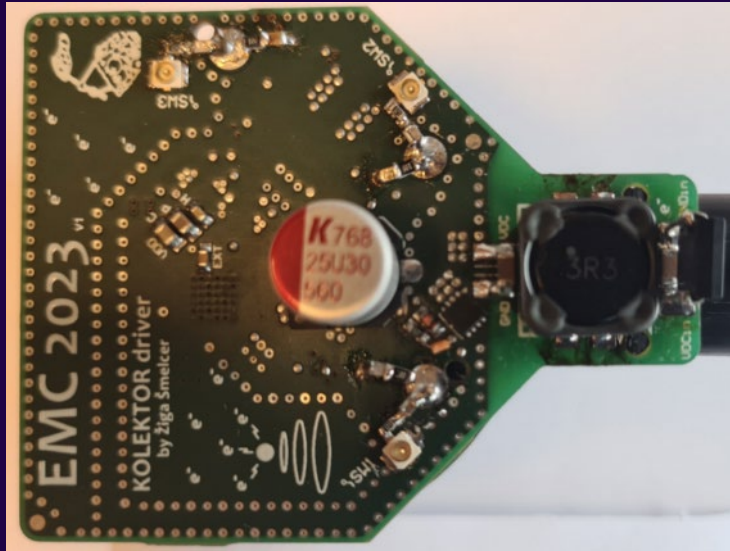

Predstavitev

Žiga Šmelcer

KOLEKTOR



Shema

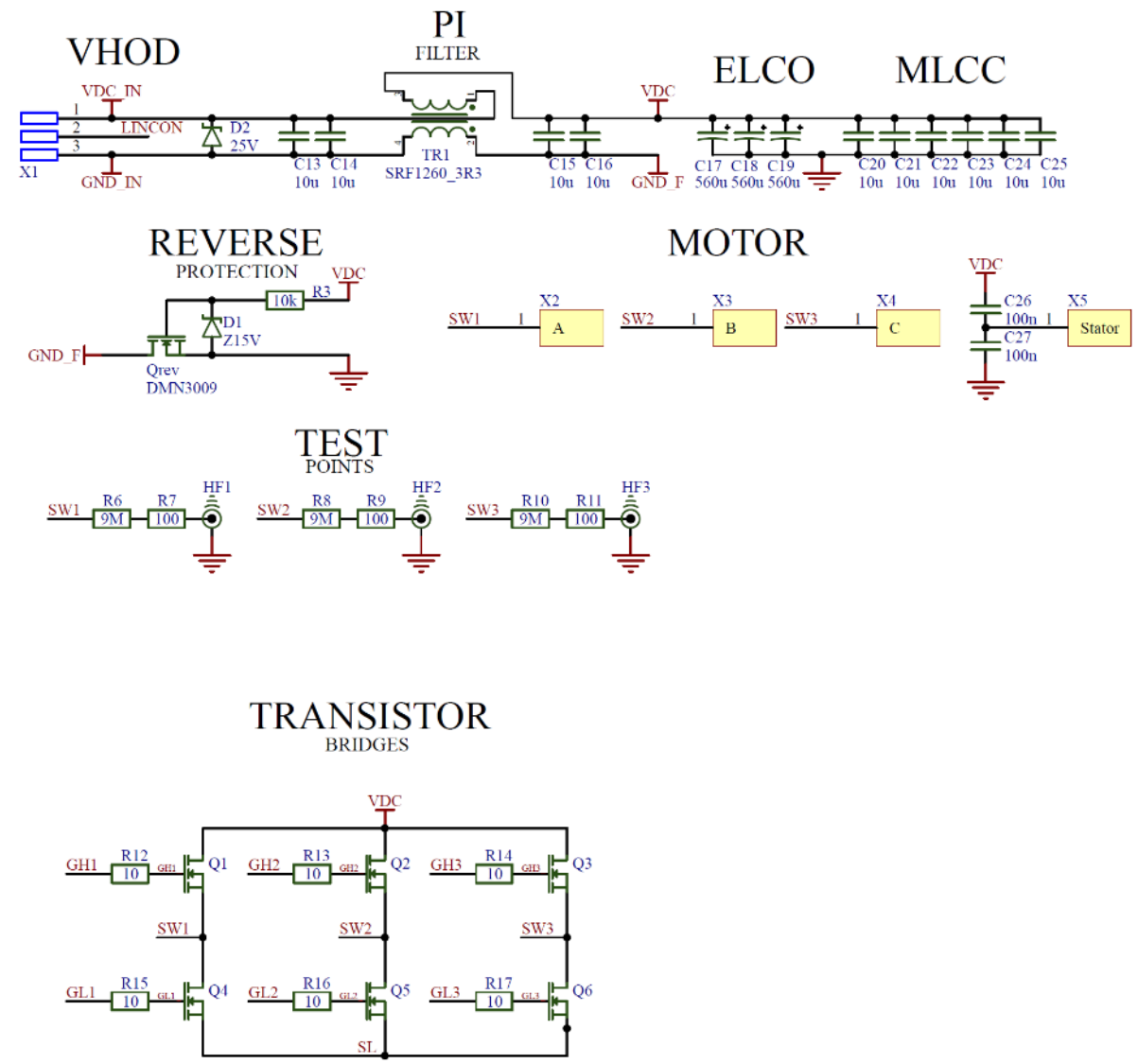
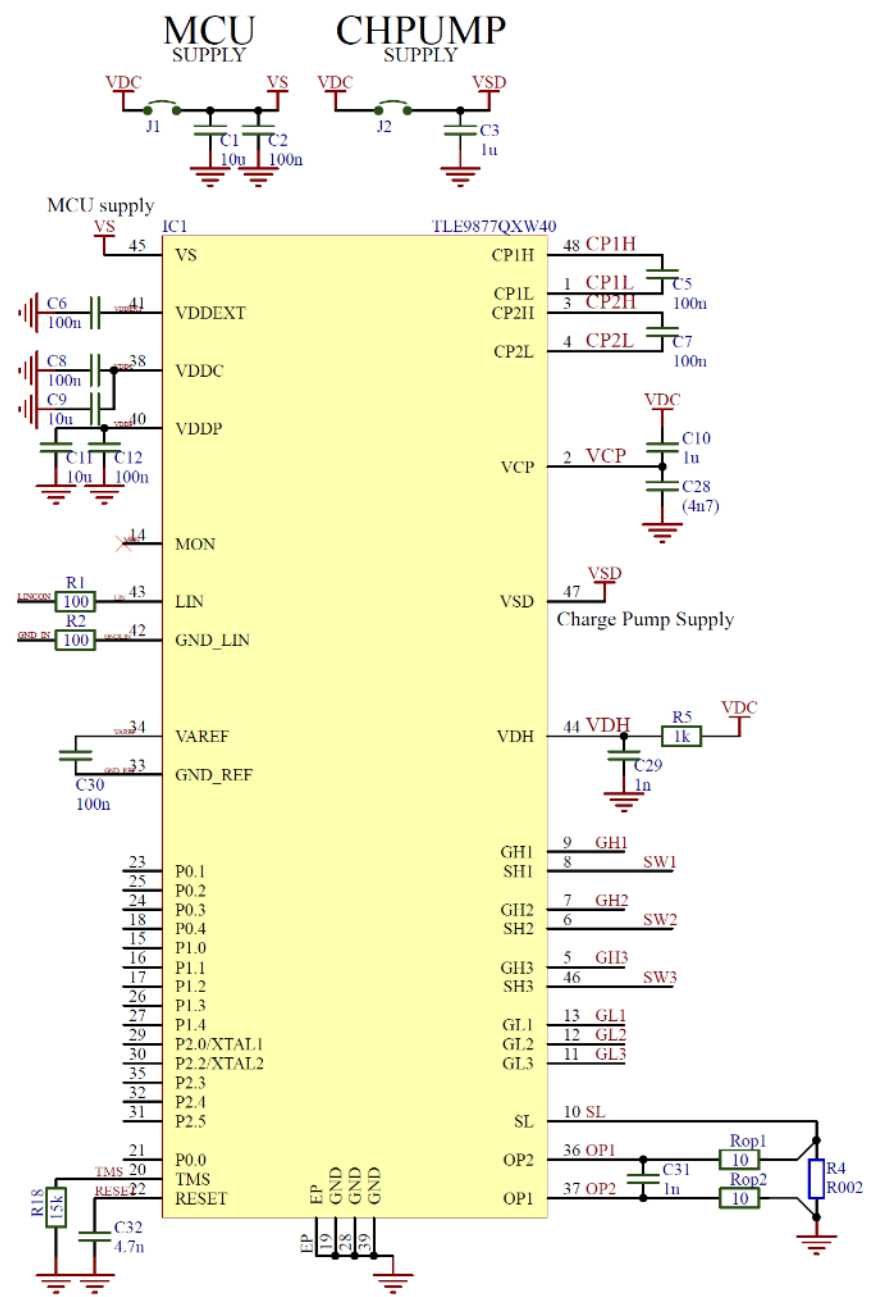

Tranzistorji - ROHM - rq3e080gntb

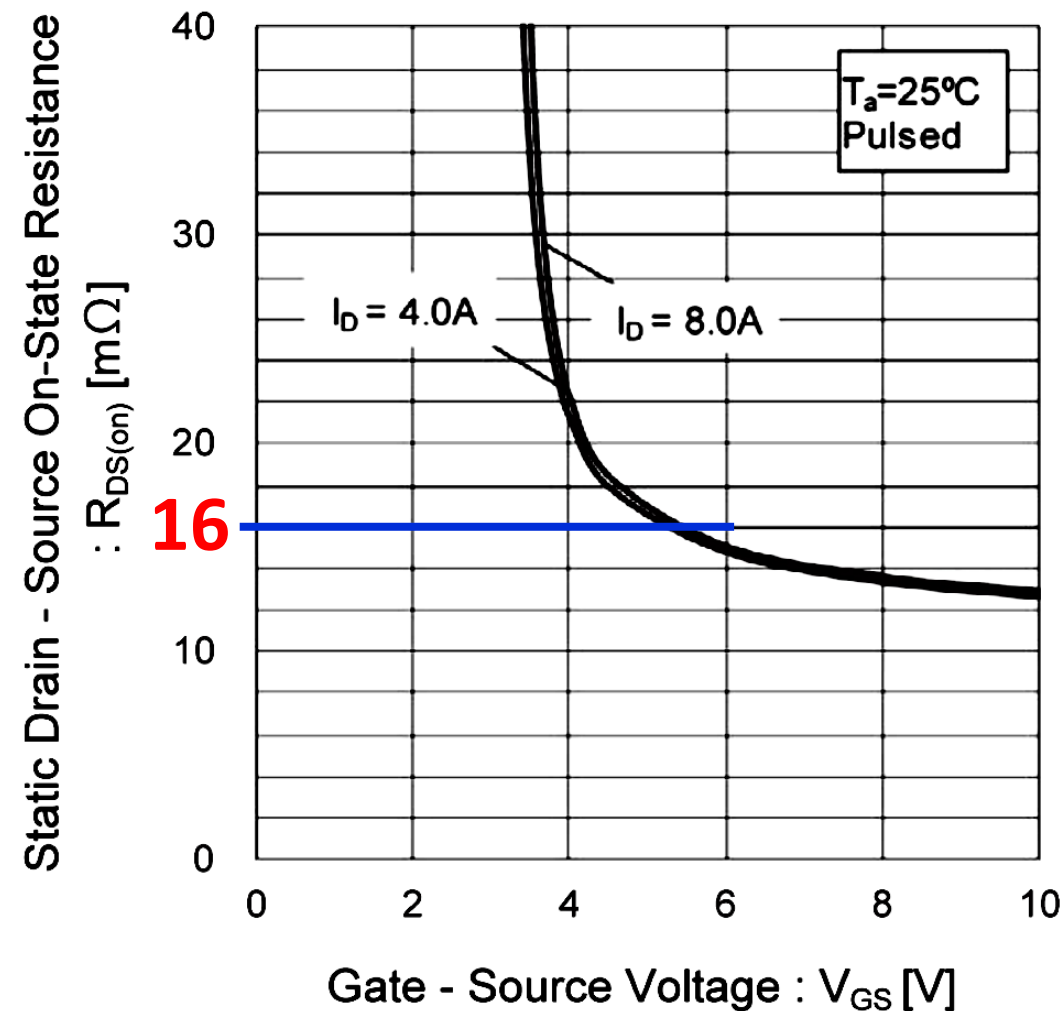
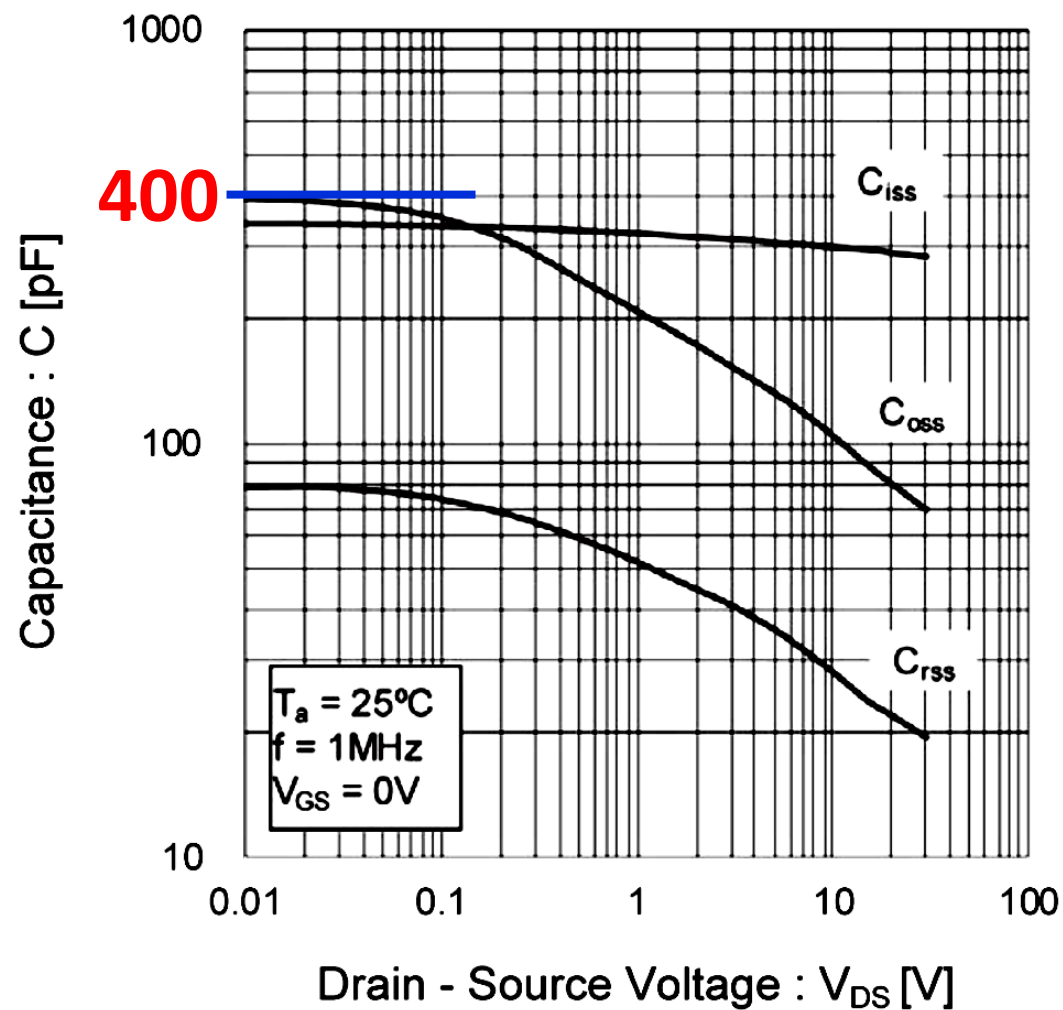

Izračuni, simulacije

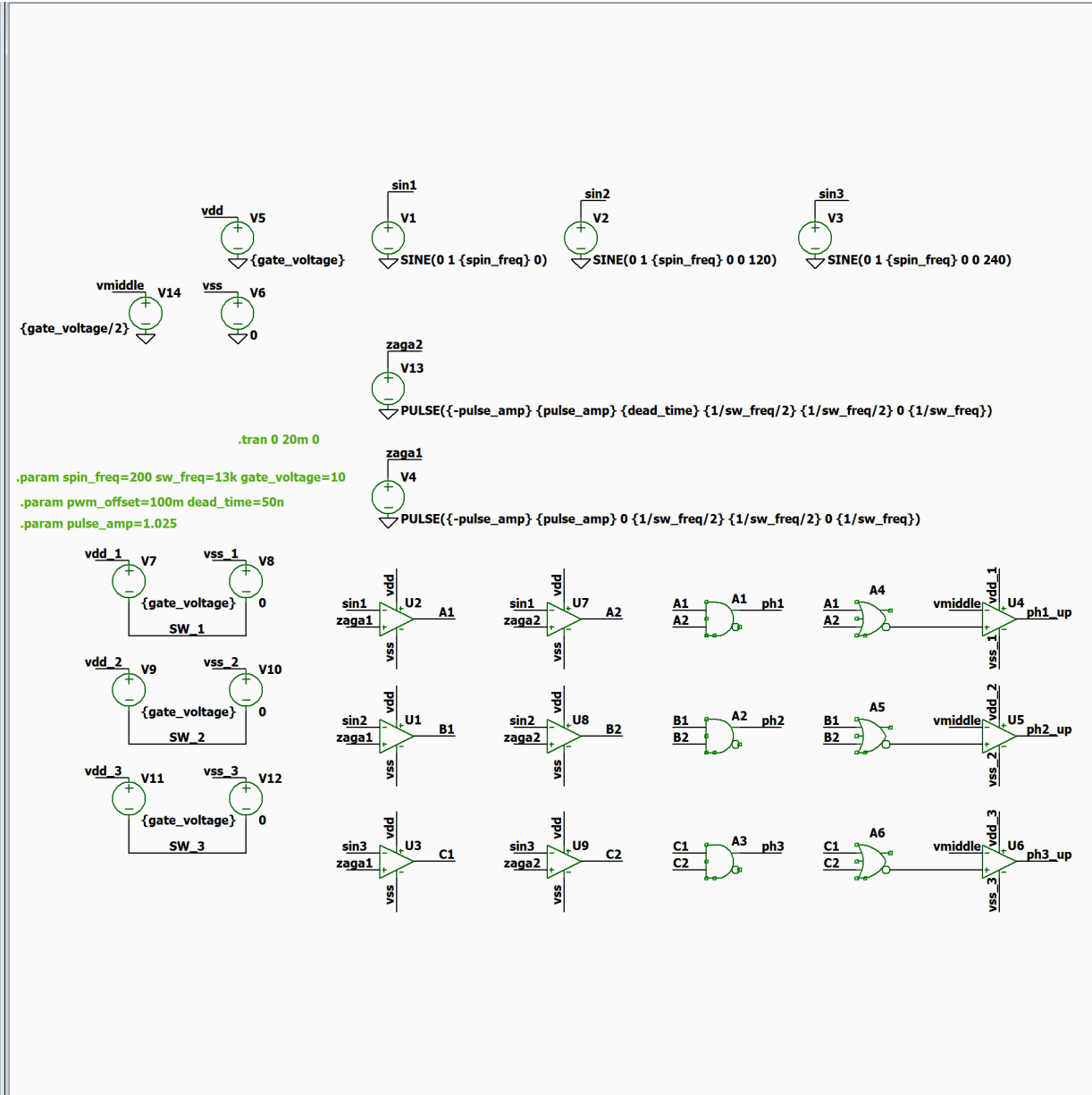
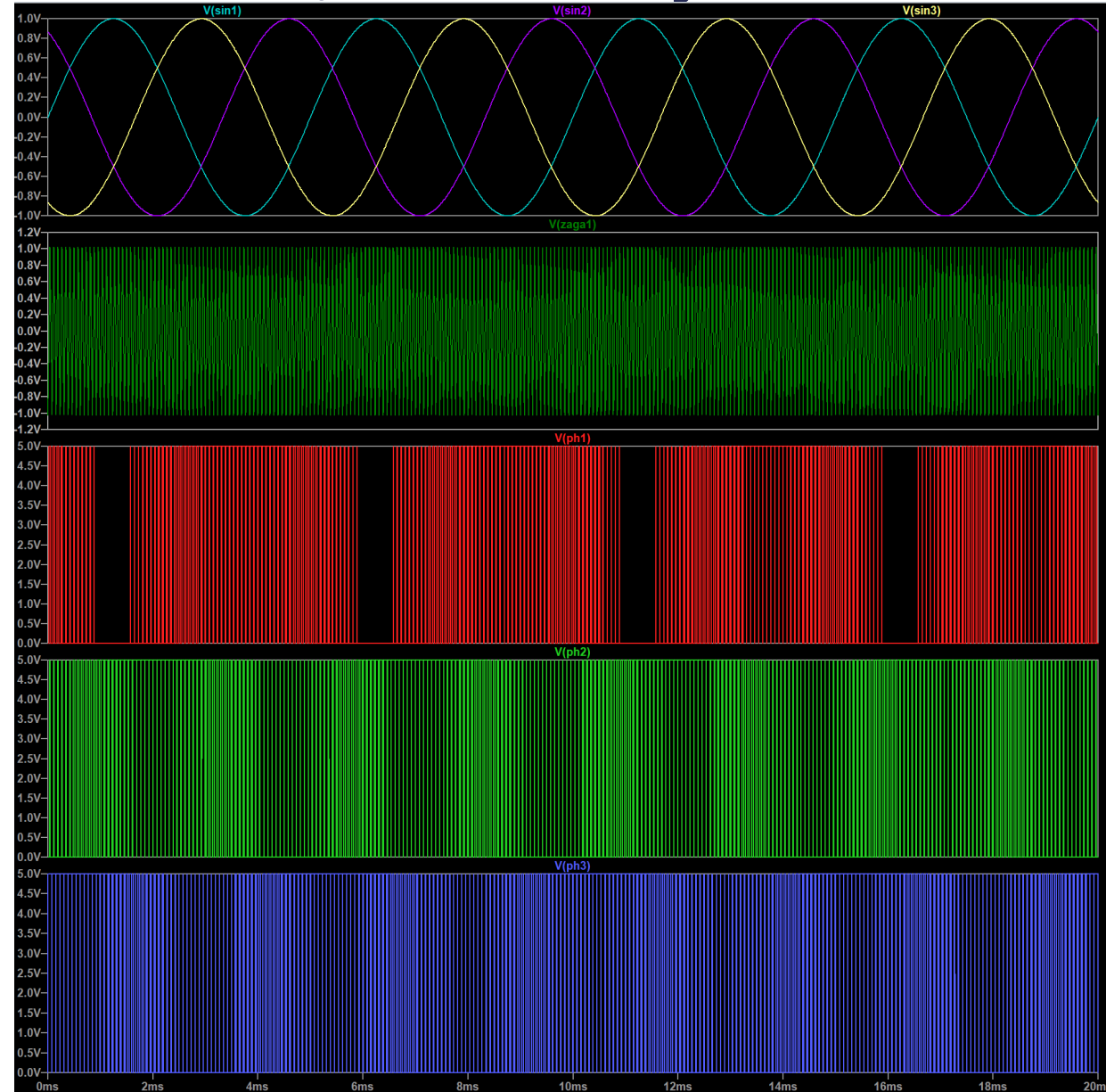

Izračuni, simulacije

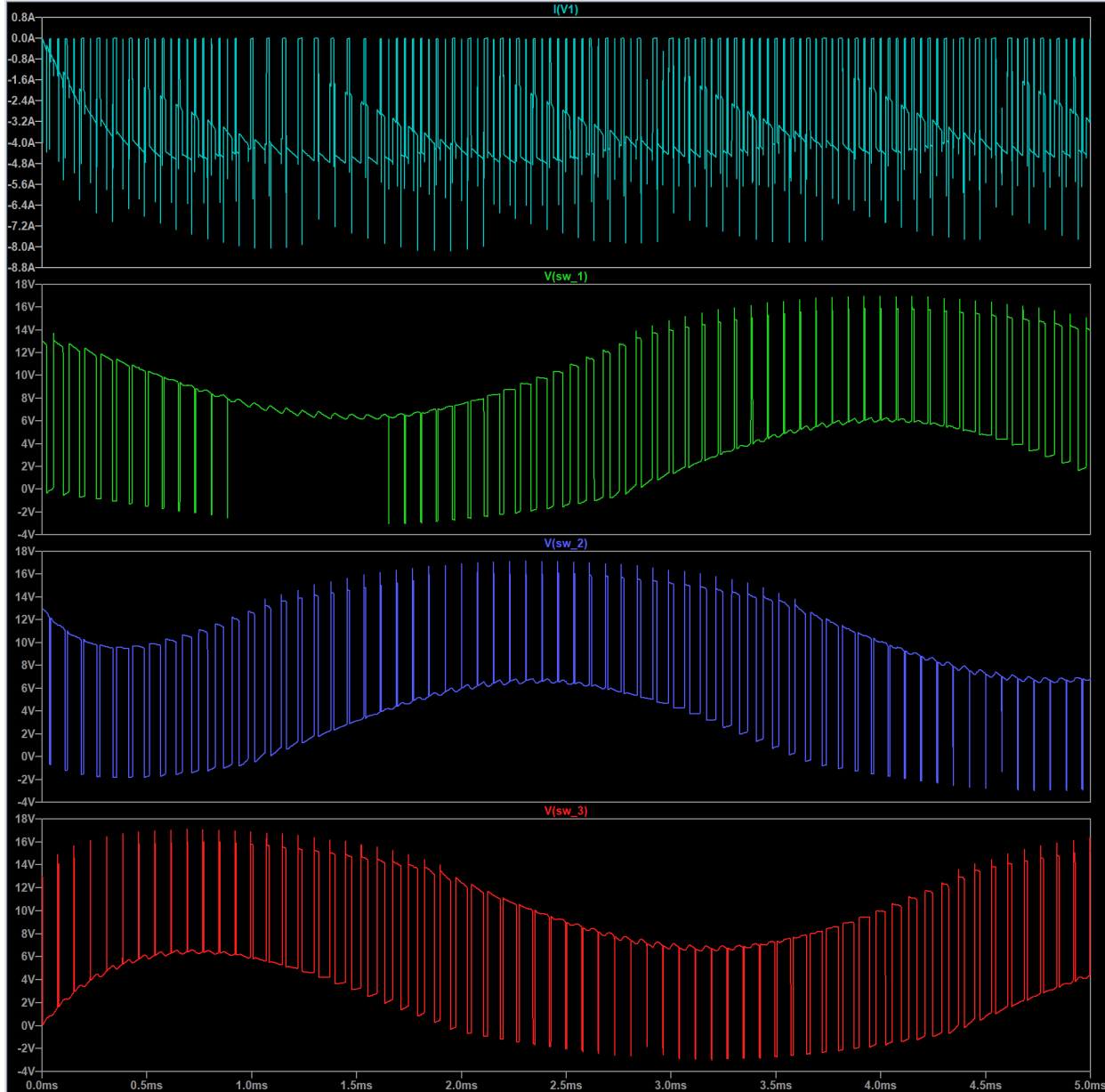

signals	X1	ph1	ph2	ph3
SW_1	SW_1	ph1	ph2	ph3
SW_2	SW_2	ph2	ph3	ph1_up
SW_3	SW_3	ph3	ph1_up	ph2_up
		ph1_up	ph2_up	ph3_up

spin_freq=200,sw_freq=13k
gate_voltage=10, dead_time=300n

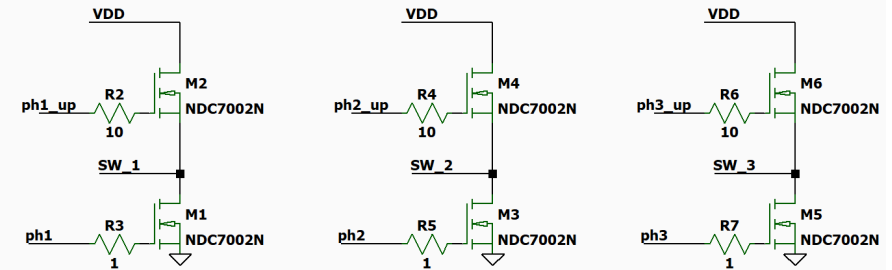

```
.tran 0 5m 0
.param tuljava=1m
K L1 L2 L3 0.05
```

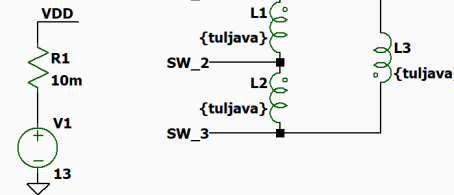

Izračuni, simulacije

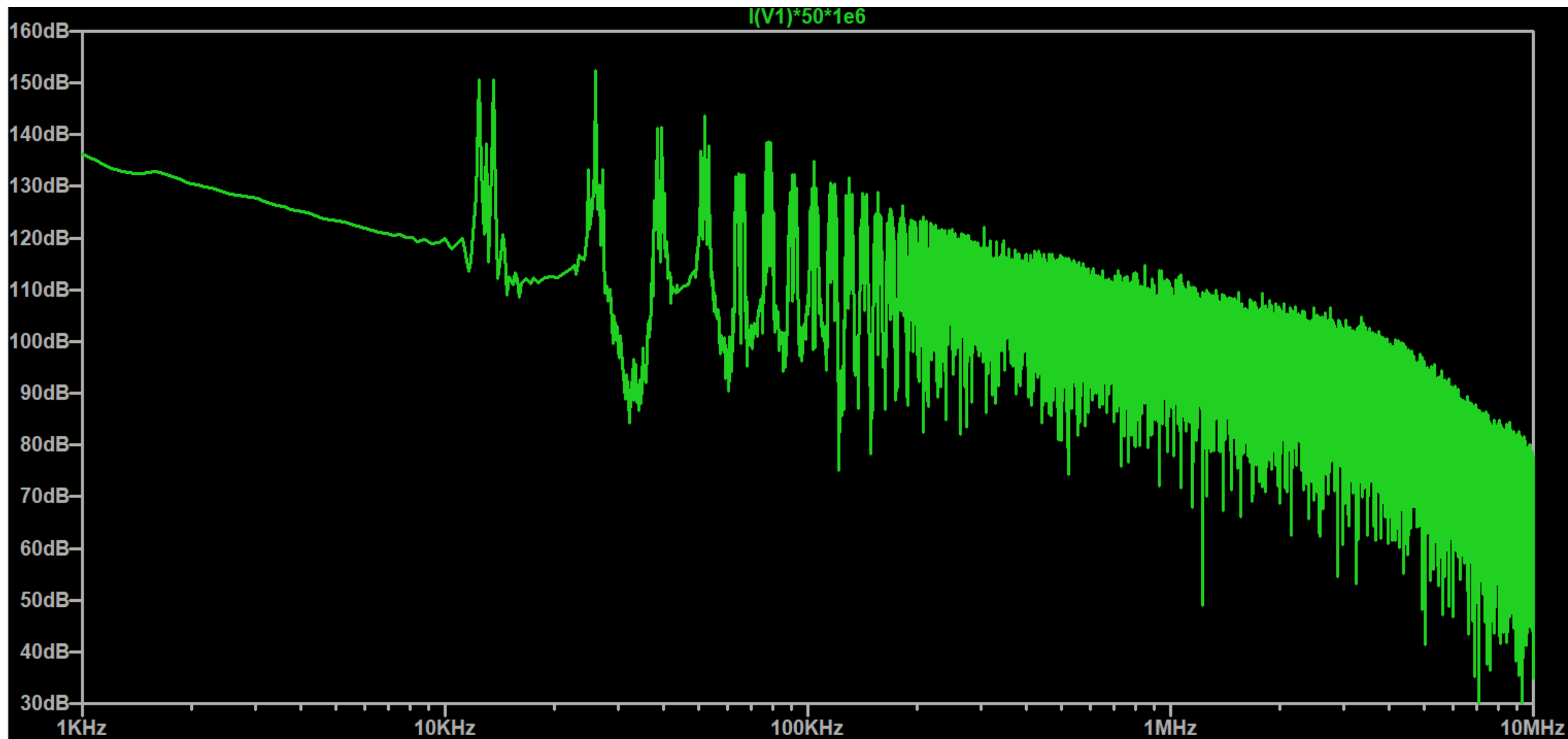

Izračuni, simulacije - SVPWM

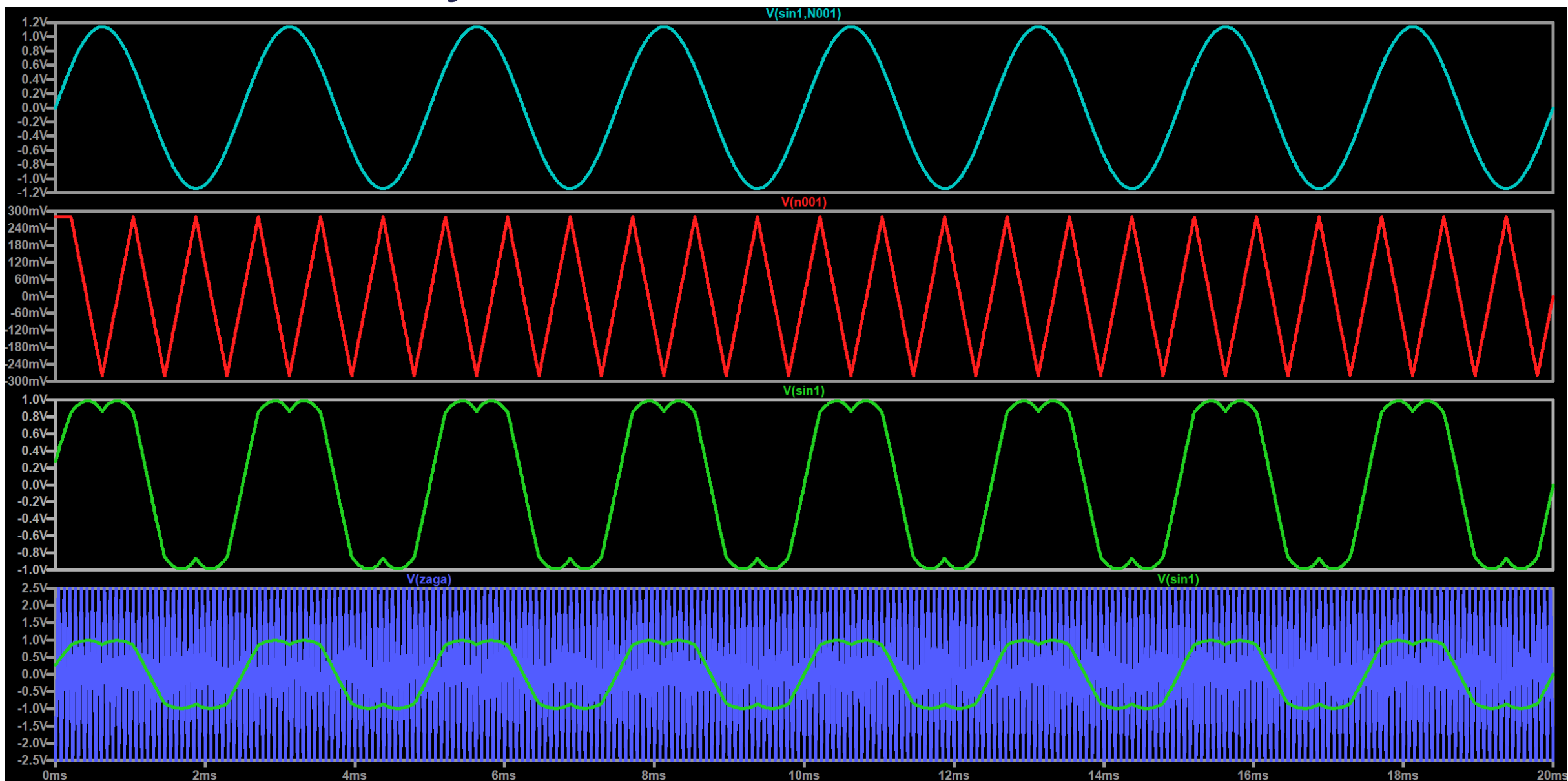

Izračuni, simulacije

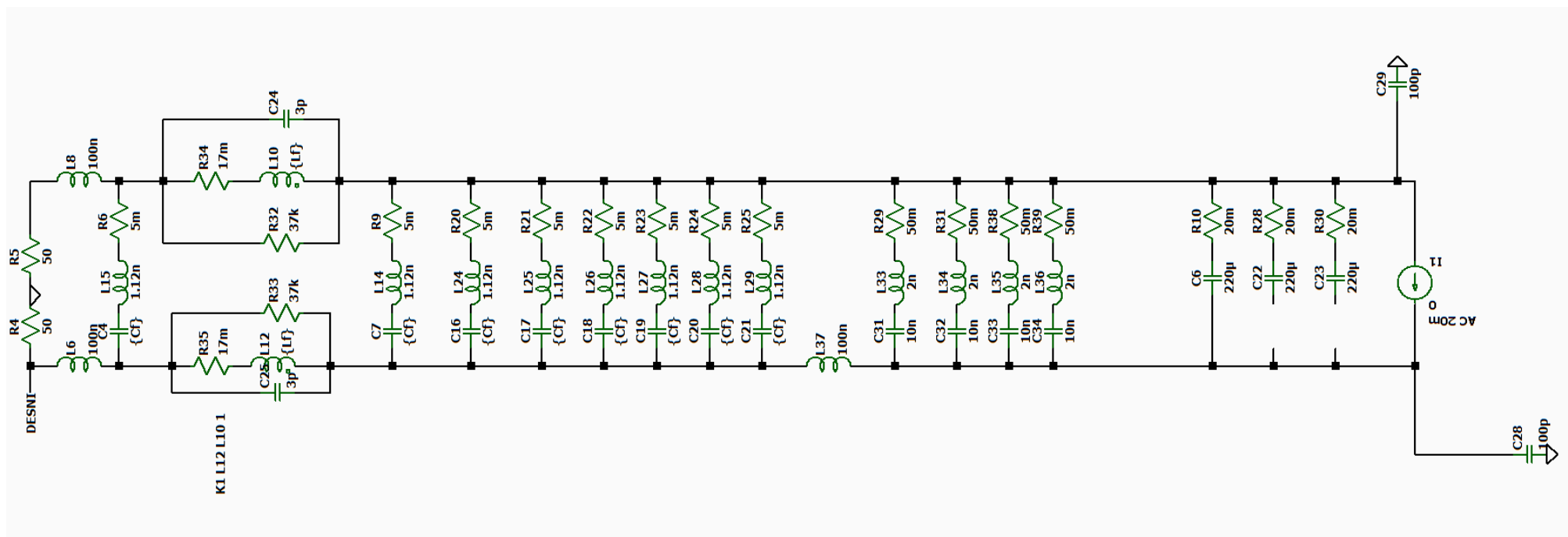
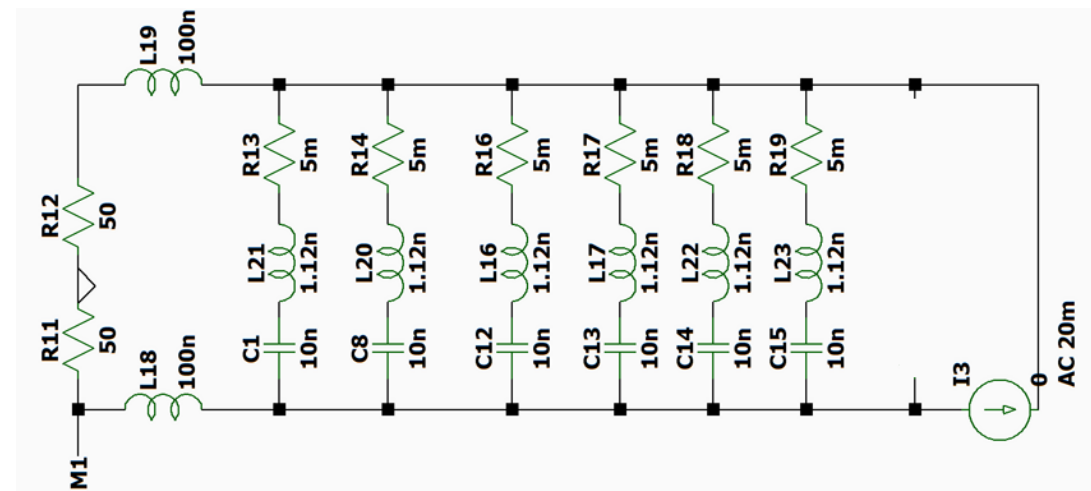
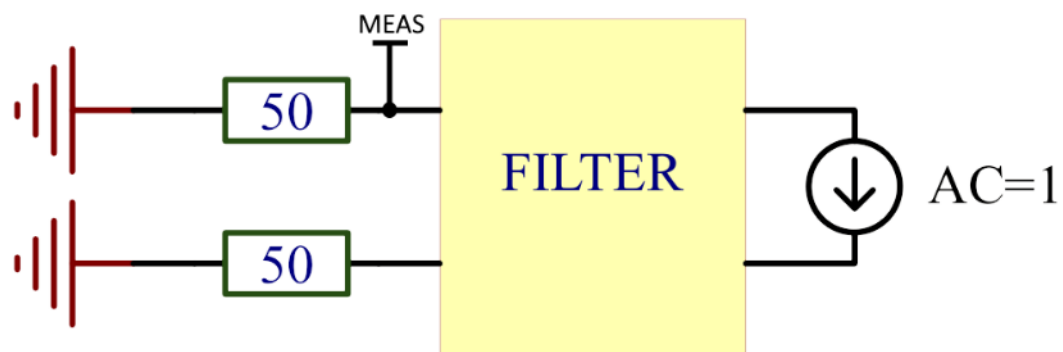

Izračuni, simulacije - relativni izračun

minimalna
konfiguracija

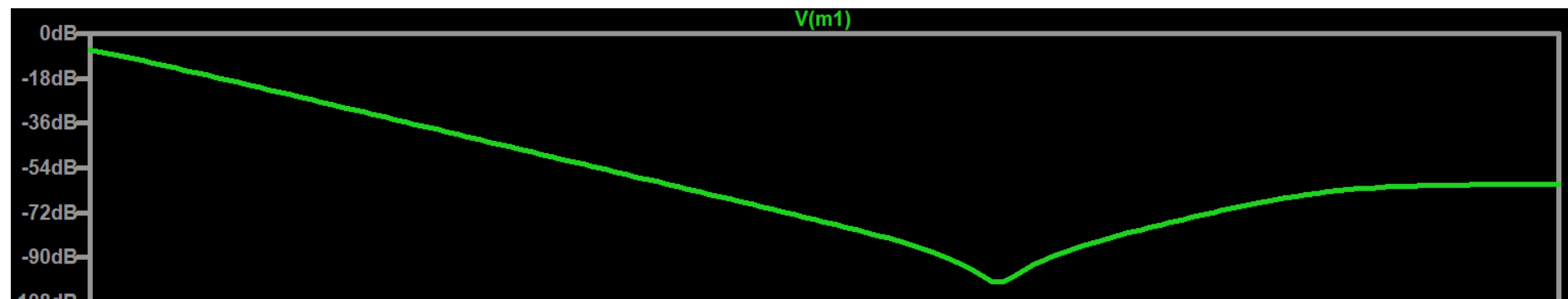

namenski
filter

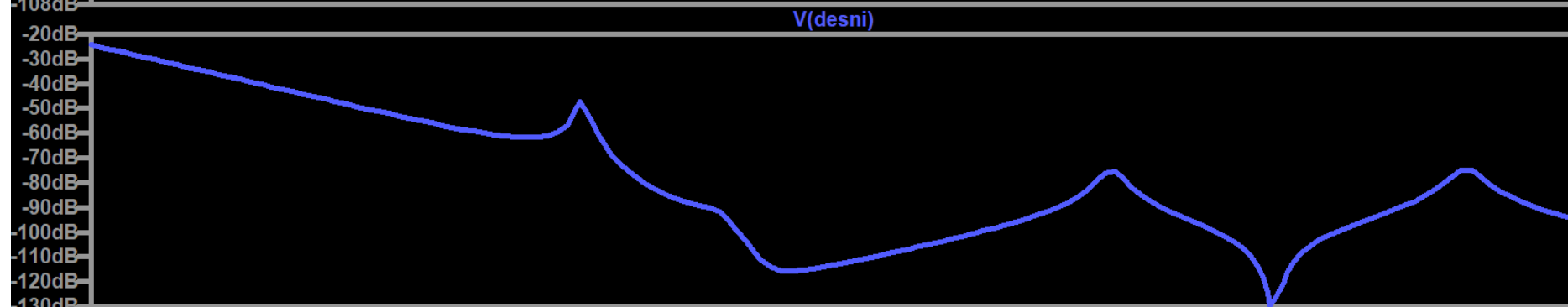

atenuacija

(upoštevamo na izmerjen
spekter motenj)

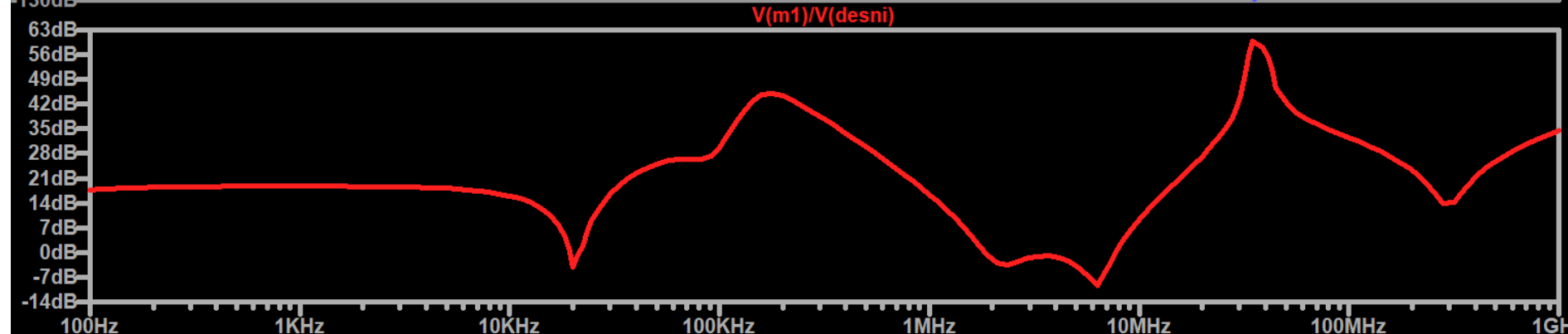

Načrt tiskanega vezja

napajalne površine (VDD, GND, VDD, GND)
YT: How to Achieve Proper Grounding - Rick Hartley

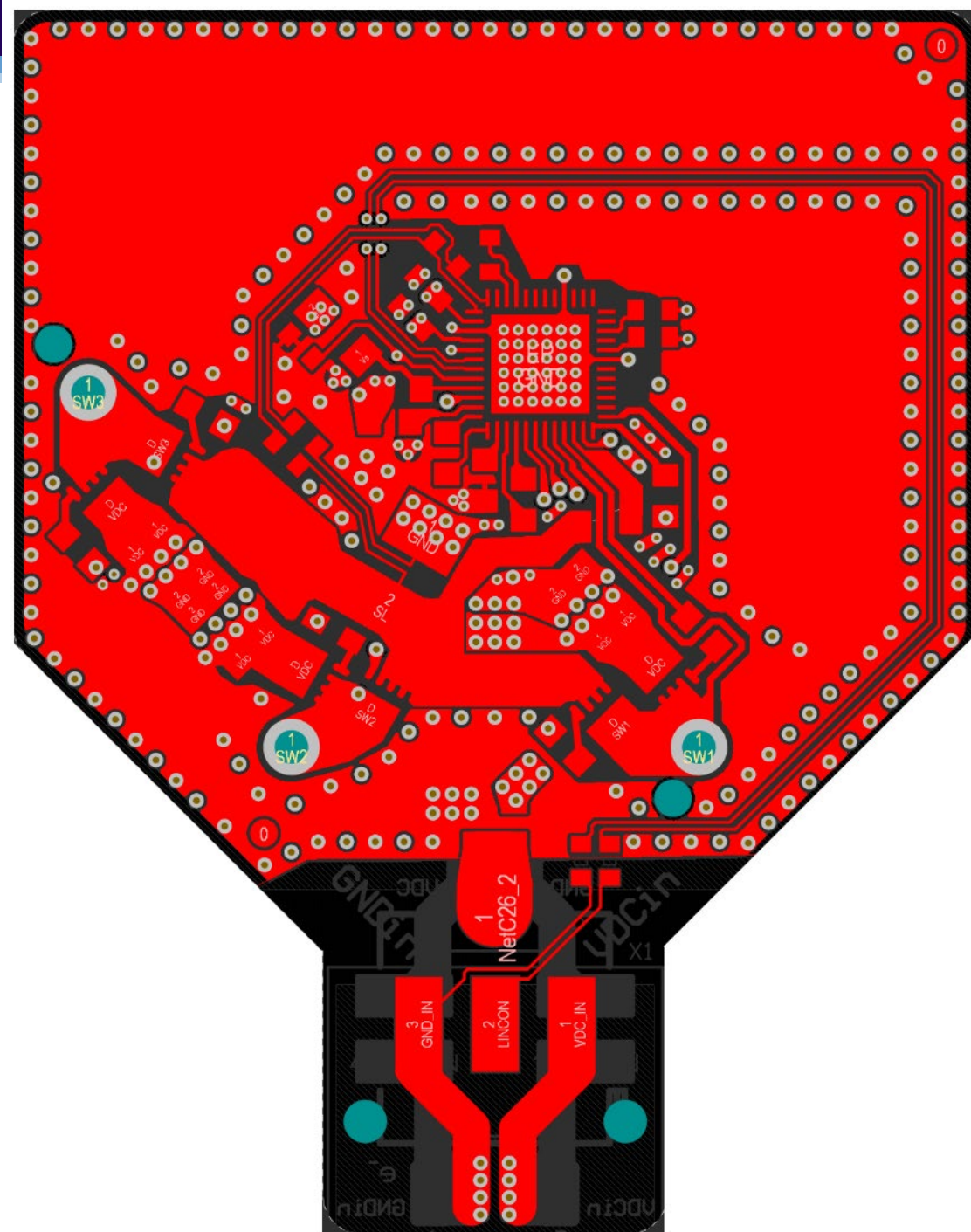

Načrt tiskanega vezja

napajalne površine (VDD, GND, VDD, GND)
YT: [How to Achieve Proper Grounding - Rick Hartley](#)

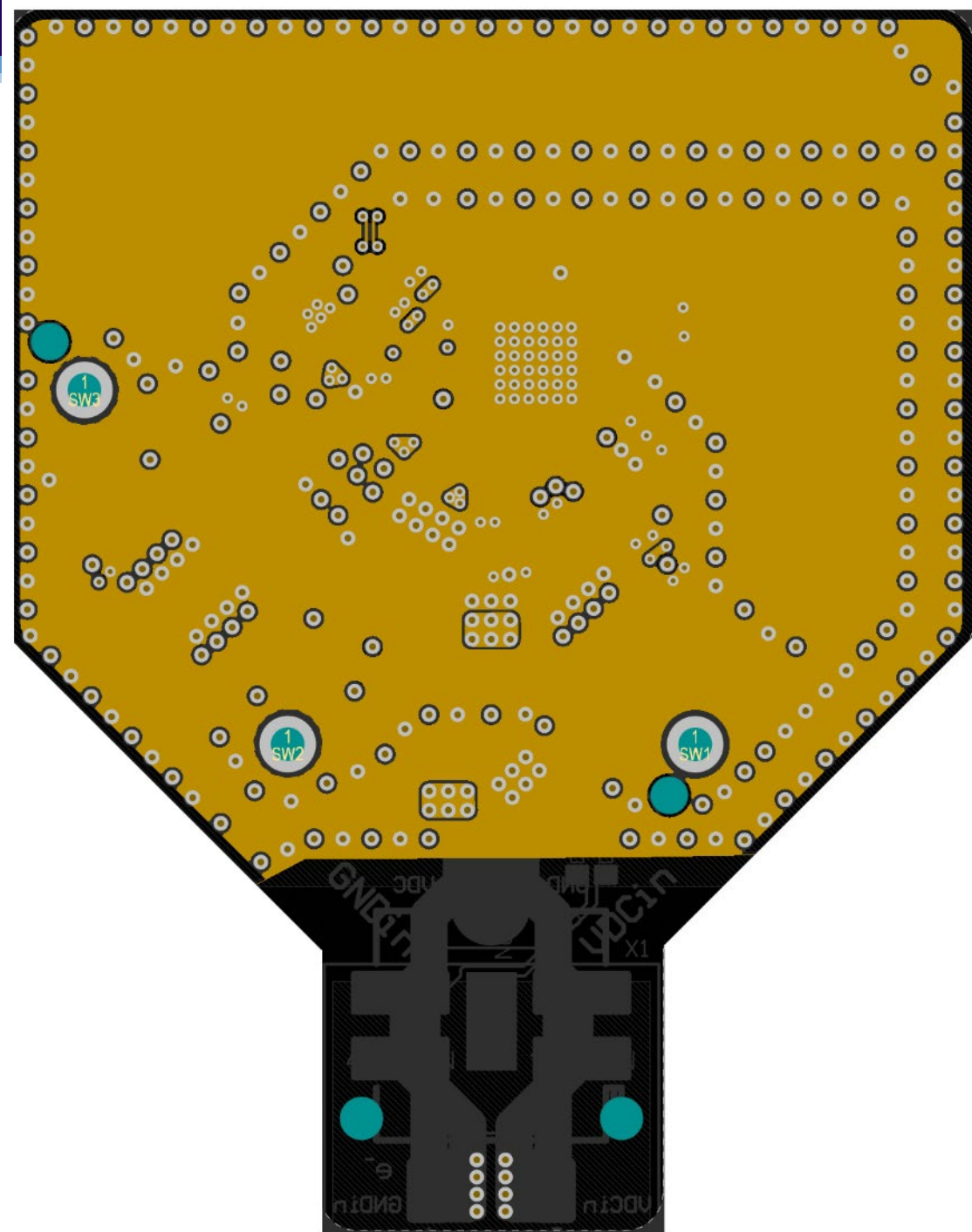
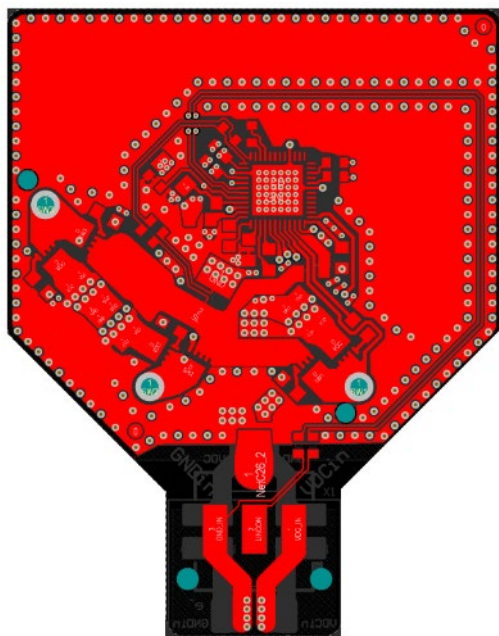

Načrt tiskanega vezja

napajalne površine (VDD, GND, VDD, GND)
YT: How to Achieve Proper Grounding - Rick Hartley

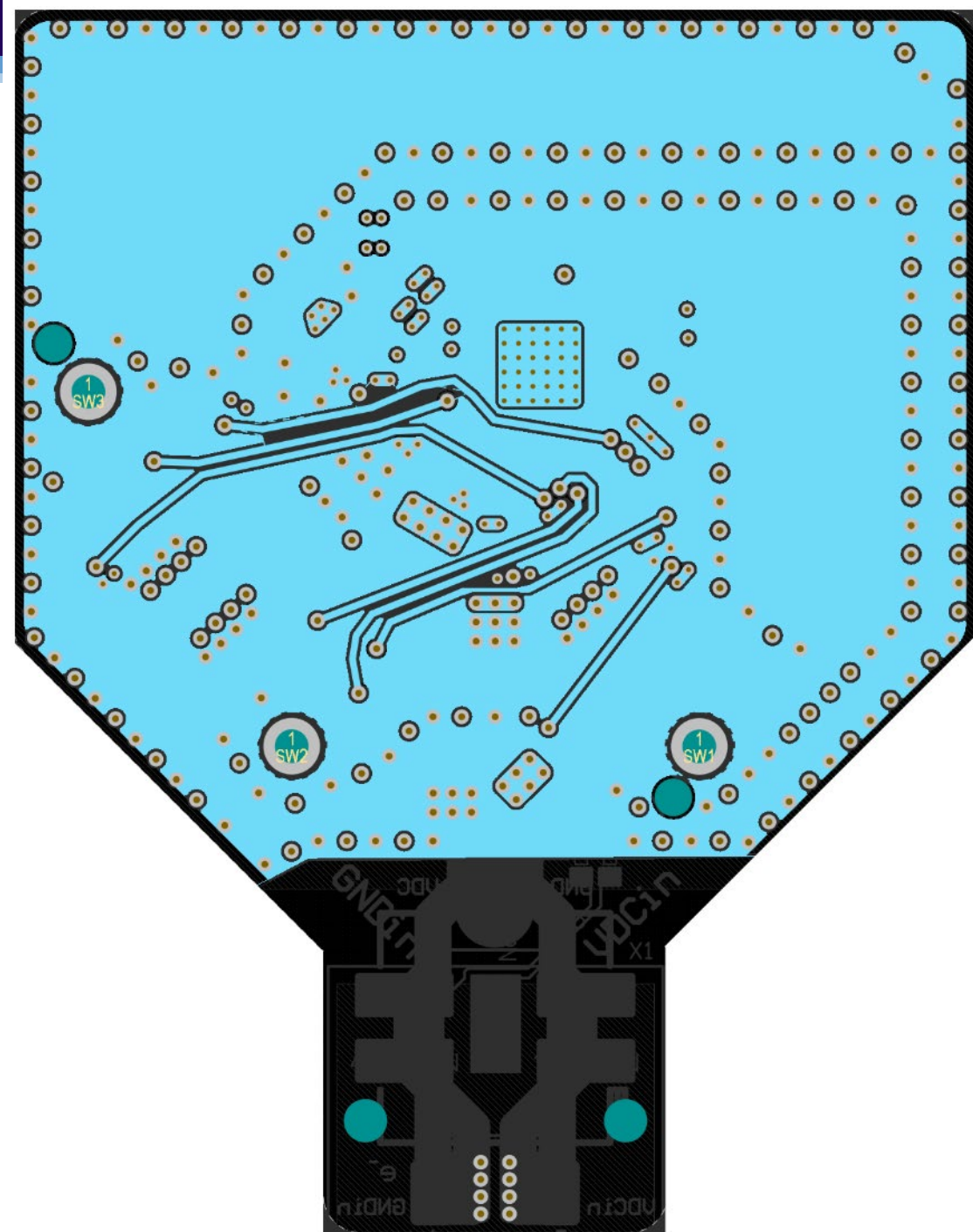
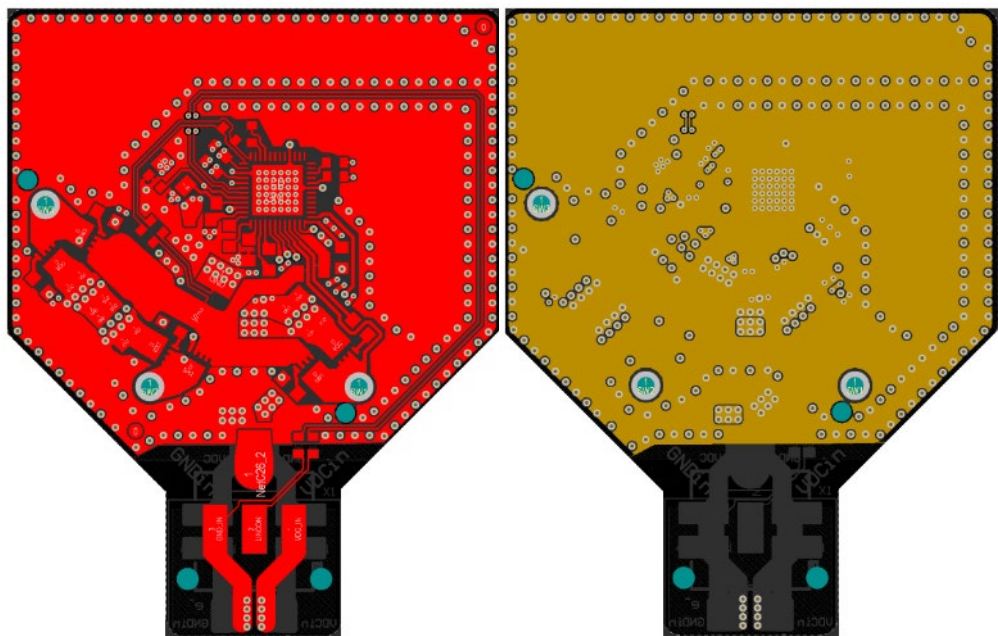

Načrt tiskanega vezja

napajalne površine (VDD, GND, VDD, GND)
 YT: How to Achieve Proper Grounding - Rick Hartley

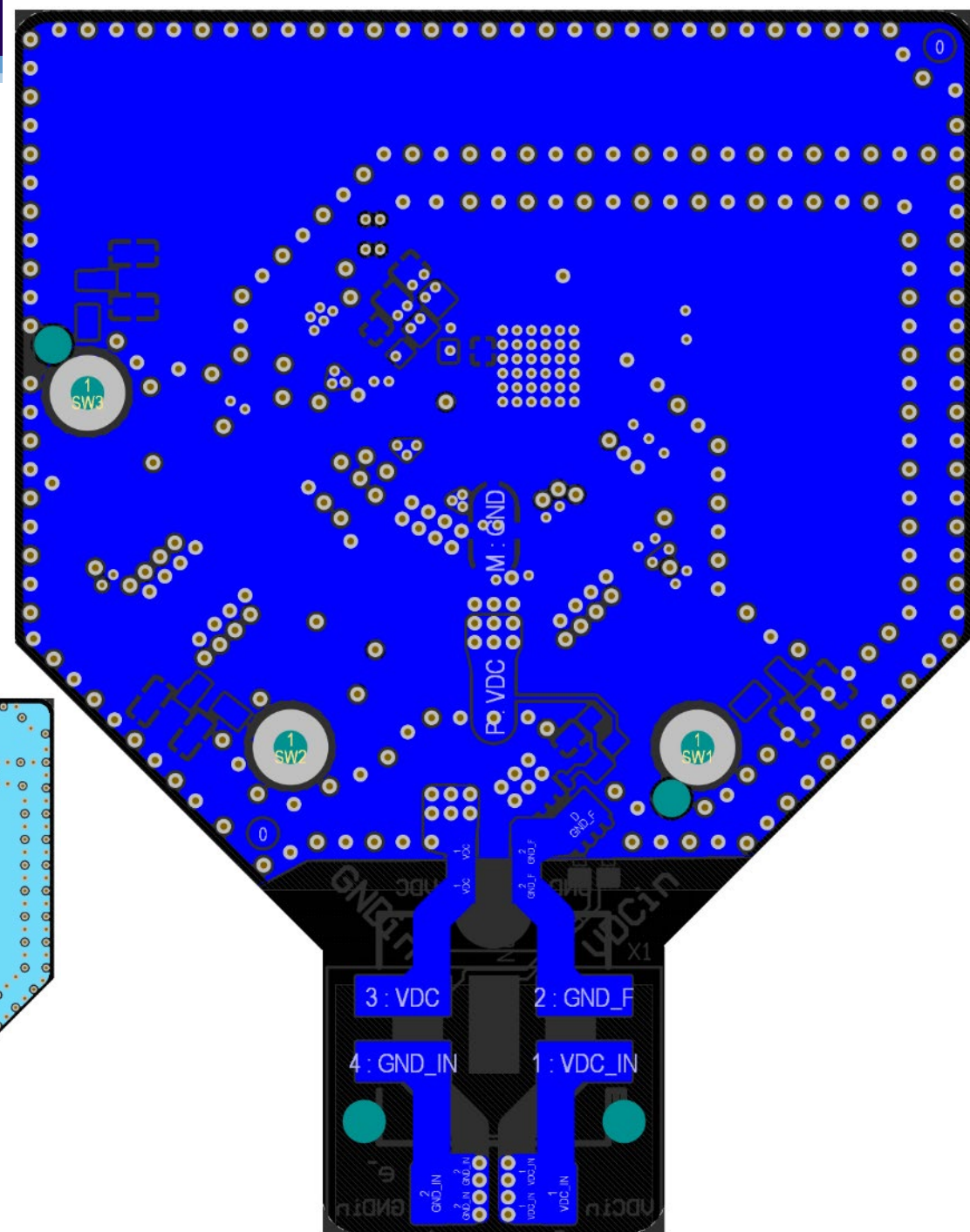
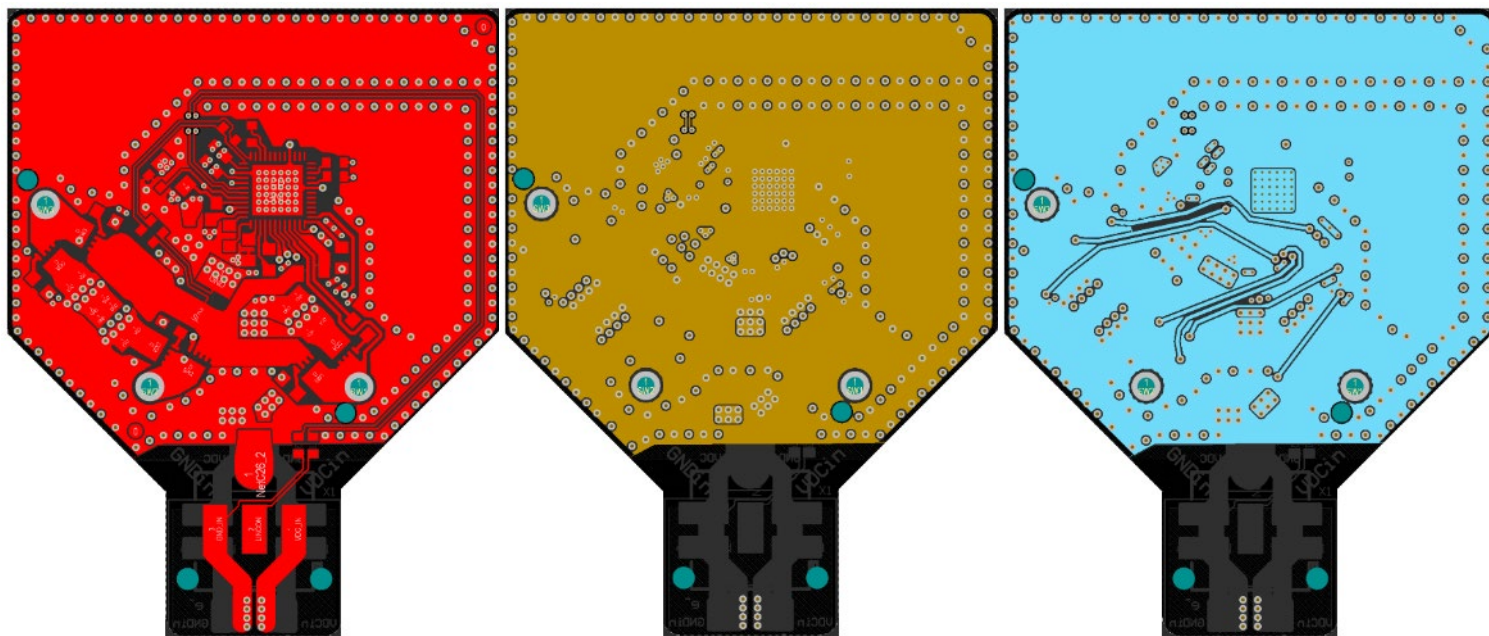

Preliminarne meritve

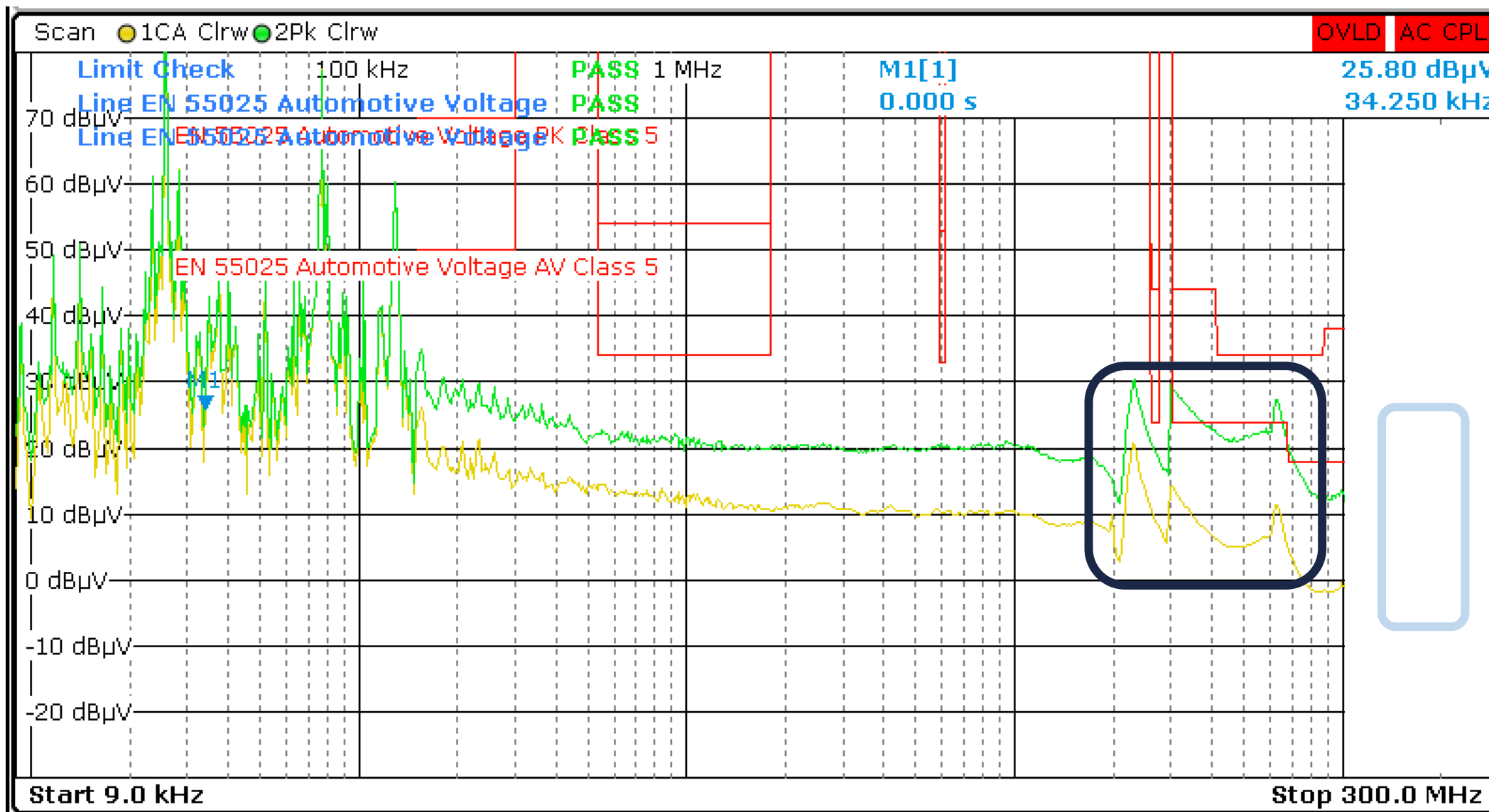

Preliminarne meritve

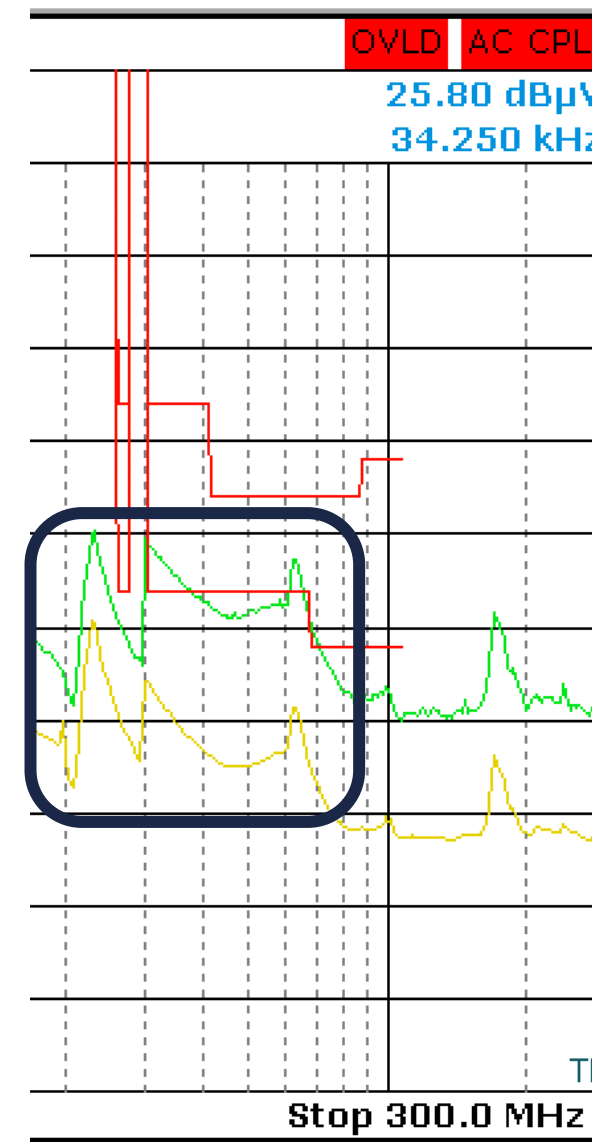
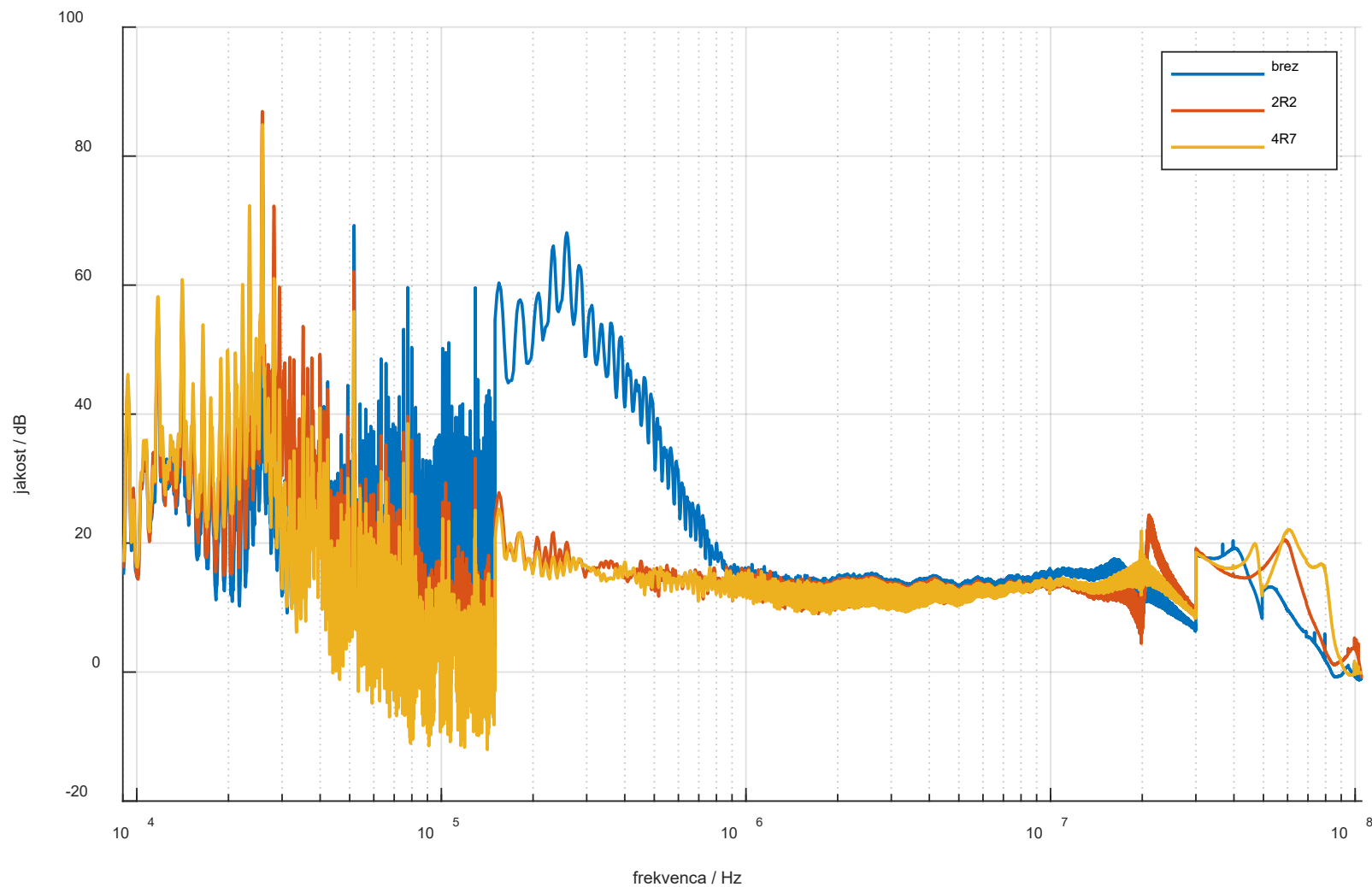

Preliminarne meritve

1.
paraziti
vezja

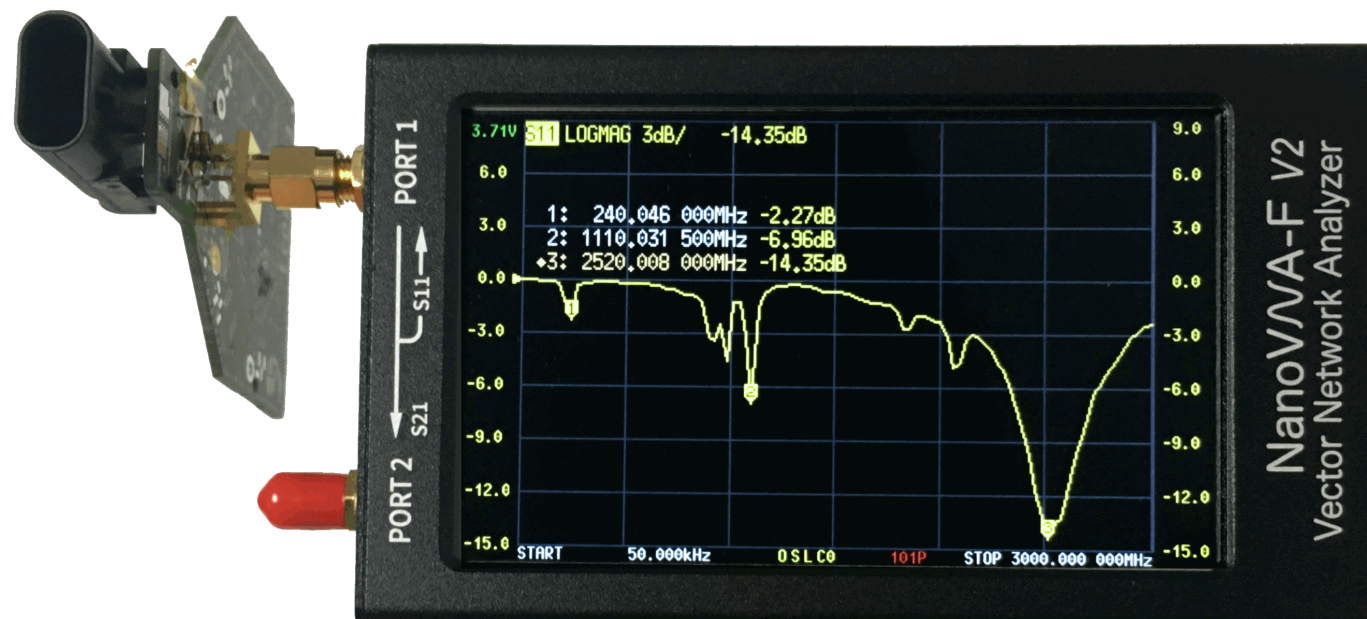

2.
MOSFET
paraziti

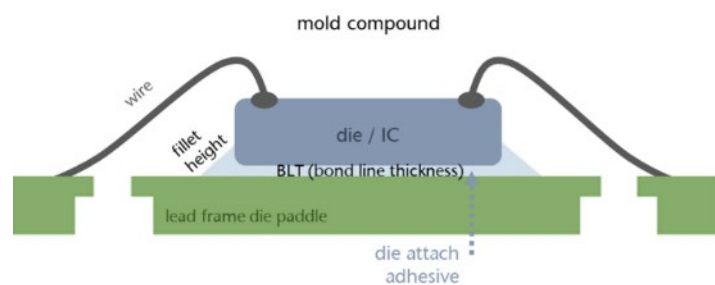

mali C
velika L

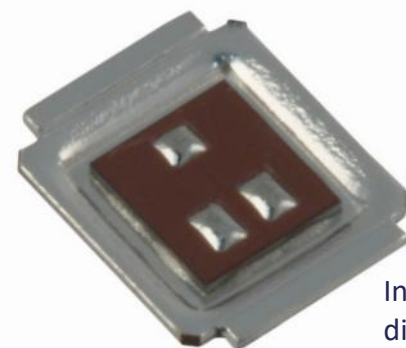

velik C
mala L

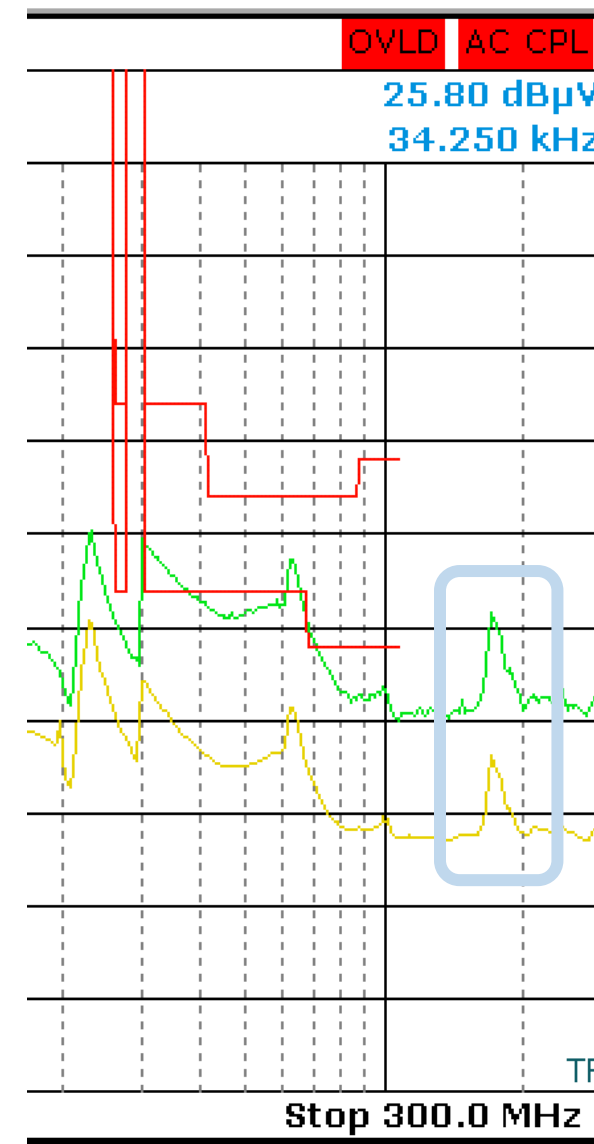

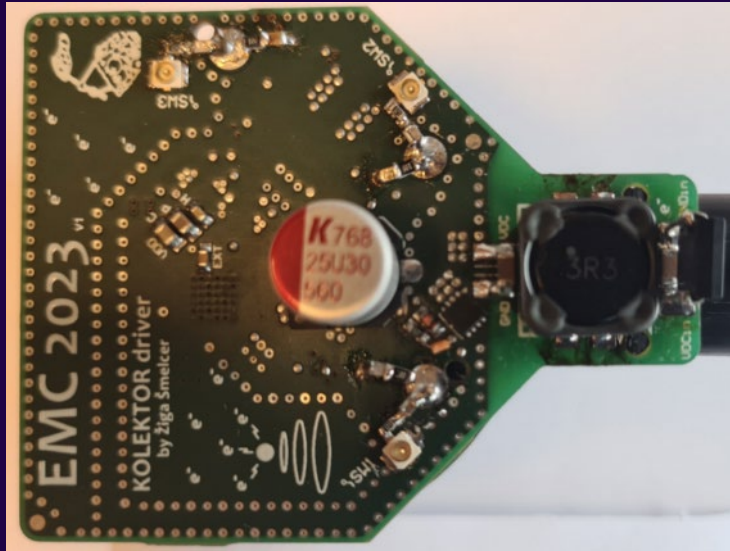

KOLEKTOR



Rezultati

Žiga Šmelcer

Žiga Šmelcer

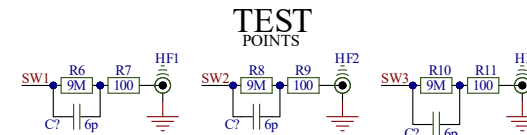
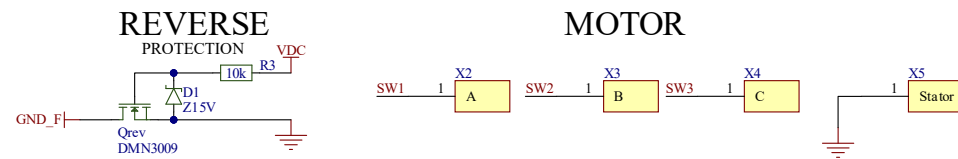
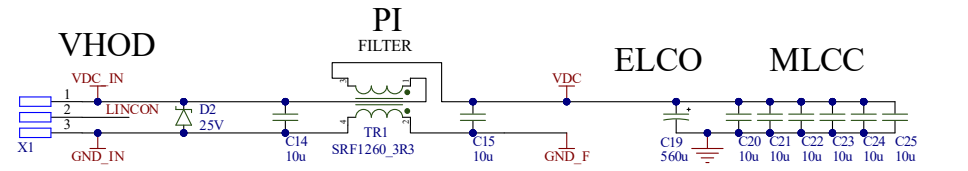
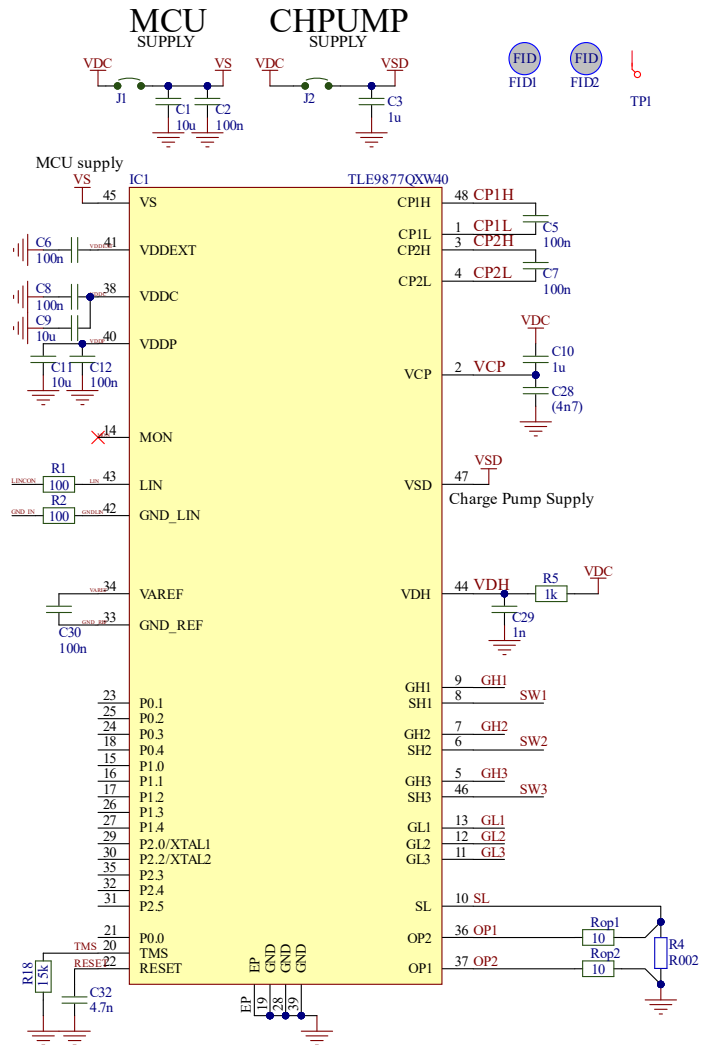

TRANSISTOR BRIDGES

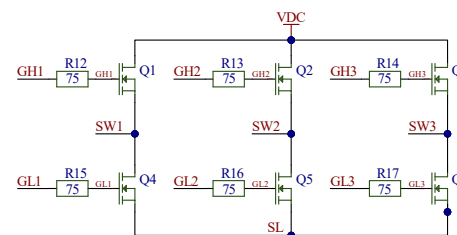

SNUBBER ZA OKRAS

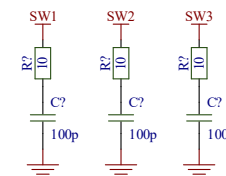

Žiga Šmelcer

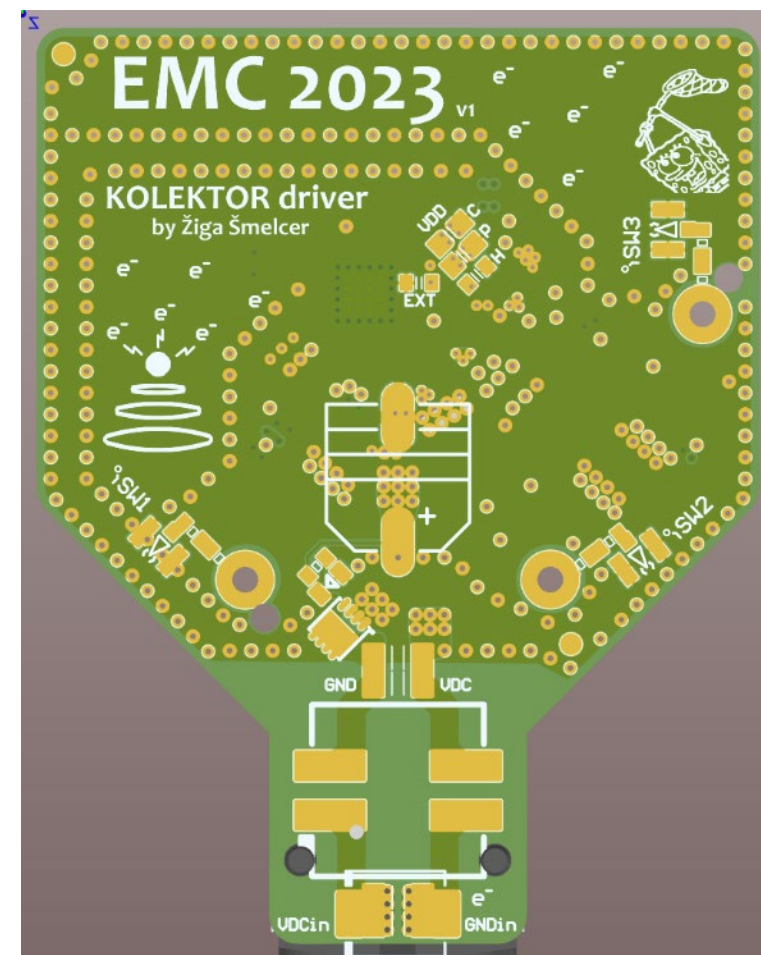
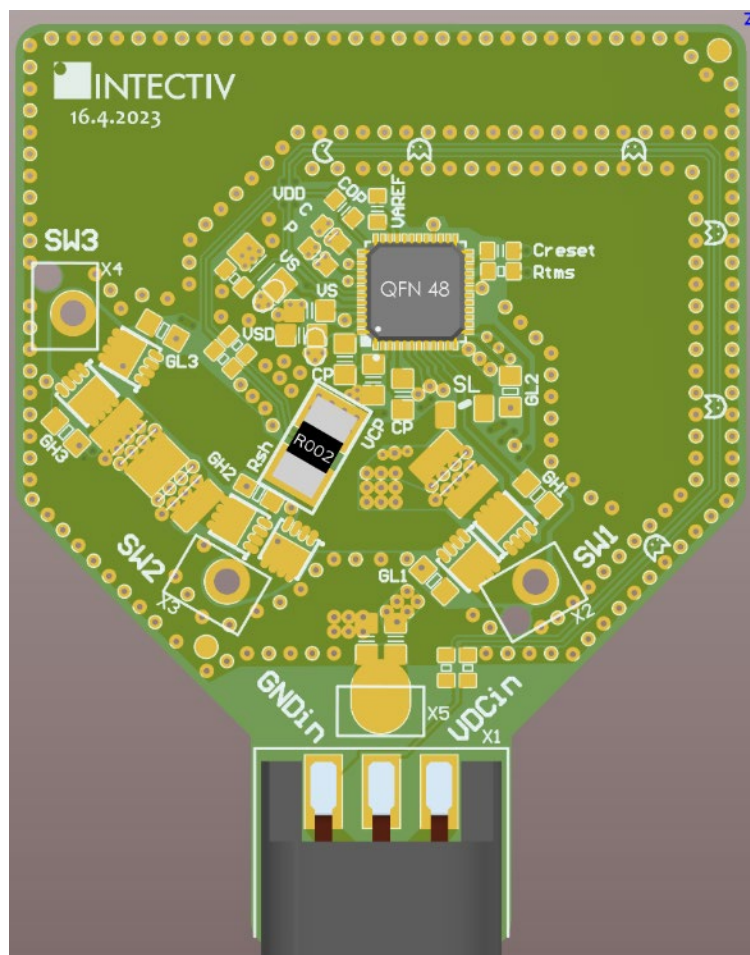

Žiga Šmelcer

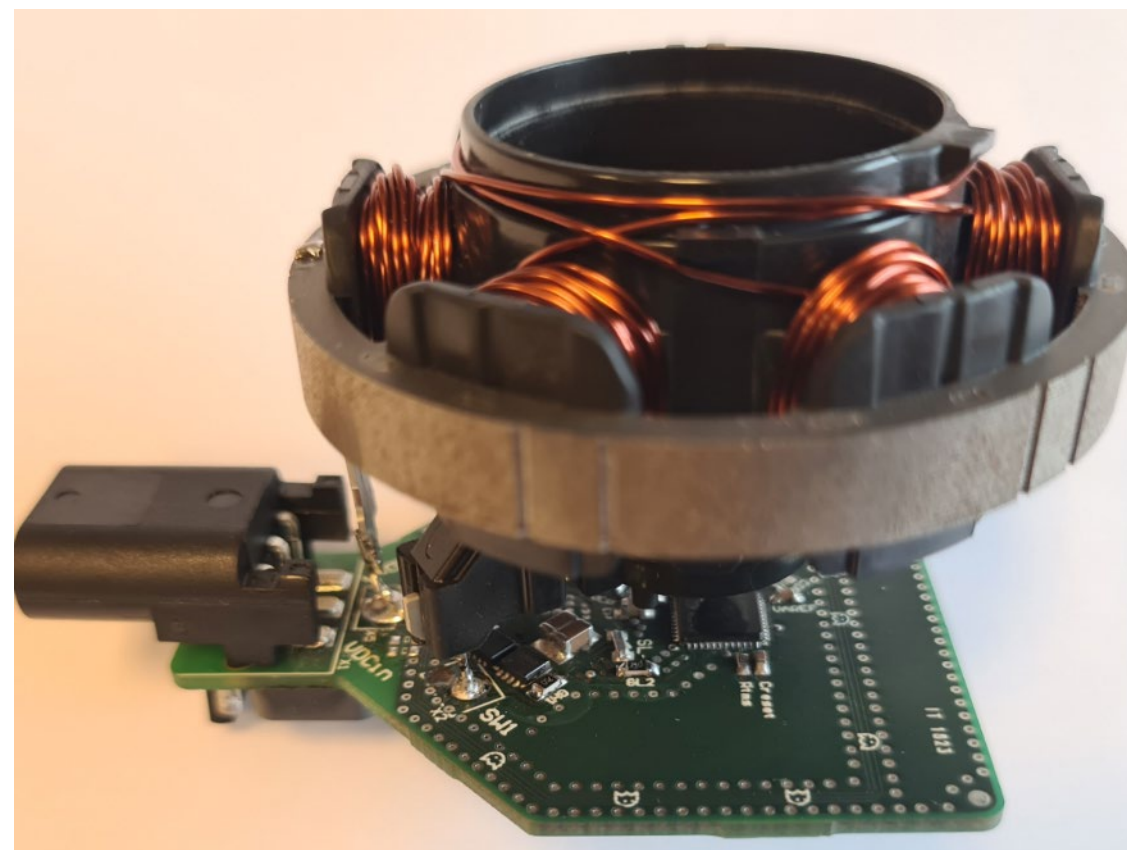
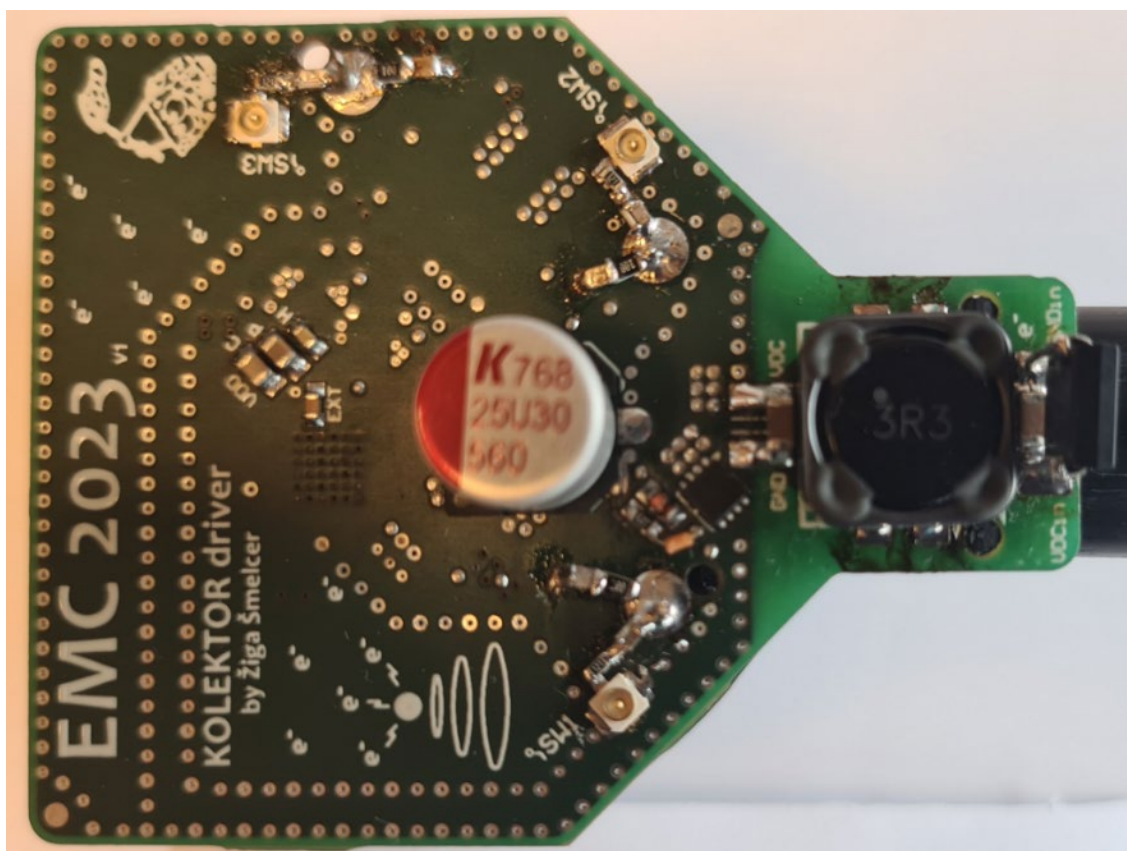

Žiga Šmelcer - BOM

No.	Query	Qty	Matches	Part	Part Description	Distributor/SKU	Unit Price	Line Total	Batch Total	Notes
1	CL31B106KAHNFN	9		Samsung CL31B106KAHNFNE	Ceramic Capacitor, Multilayer, Ceramic, 25V, 10% +Tol, 10% -Tol, X7R, 15% TC, 10uF,	Future Electronics 8111042 Stock: 54.000 Tape & Reel	≈ 0,0279	≈ 0,2507	≈ 250,6606	
2	A768MS567M1ELA	1		KEMET A768MS567M1ELAE017	Cap Alum Poly 560UF 20% 25V SMD	Mouser 80-A768MS567M1ELAE17 Stock: 3.116 Tape & Reel	0,2840	0,2840	284,0000	
3	DMN3009LFV-7	1		Diodes Inc. DMN3009LFV-7	Trans MOSFET N-CH 30V 60A 8-Pin PowerDI EP T/R	DigiKey 31-DMN3009LFV-7CT-ND Stock: 2.000 Cut Tape	0,1708	0,1708	170,8300	Ni Automotive
4	RQ3E080GNTB	6		ROHM RQ3E080GNTB	Trans MOSFET N-CH 30V 8A Automotive 8-Pin HSMT EP T/R	Avnet RQ3E080GNTB Stock: 0	≈ 0,1158	≈ 0,6951	≈ 695,0978	
5	SRF1260A-3R3Y	1		Bourns SRF1260A-3R3Y	Ind Power Shielded Wirewound 3.3uH/13.2uH 30% 100KHz Ferrite 9.26A/4.63A T/R	Arrow Electronics SRF1260A-3R3Y Stock: 13 Cut Tape	≈ 0,5115	≈ 0,5115	≈ 511,5426	
6	ZMM15	1		Diotec ZMM15	Diode Zener Single 14.7V 6% 500mW Automotive 2-Pin Mini- MELF T/R	TME ZMM15-DIO Stock: 8.825	0,0163	0,0163	16,3000	

Tekmovalec	cena tranzistorjev	Cena kondenzatorjev	Cena dušilk	Cena diod	Skupaj
Žiga Šmelcer	0,87 €	0,53 €	0,51 €	0,02 €	1,93 €

Tekmovalec	kvalifikacija	temp. območje	ostale zahteve	Cena komponent	Točke
Žiga Šmelcer	0	3	3	1,93 €	-3,65

Žiga Šmelcer - delovanje

- Izkoristek 86,12 %
- Prenihaj 2,6 V
- Padec napetosti 0,148 V
- Tok nasprotne polaritete 1 A

Tekmovalec	Osnovna	Izkoristek	Polariteta	Padec r	Prenihaj	Točke
Žiga Šmelcer	12	12	0	5	5	34

Žiga Šmelcer - CE

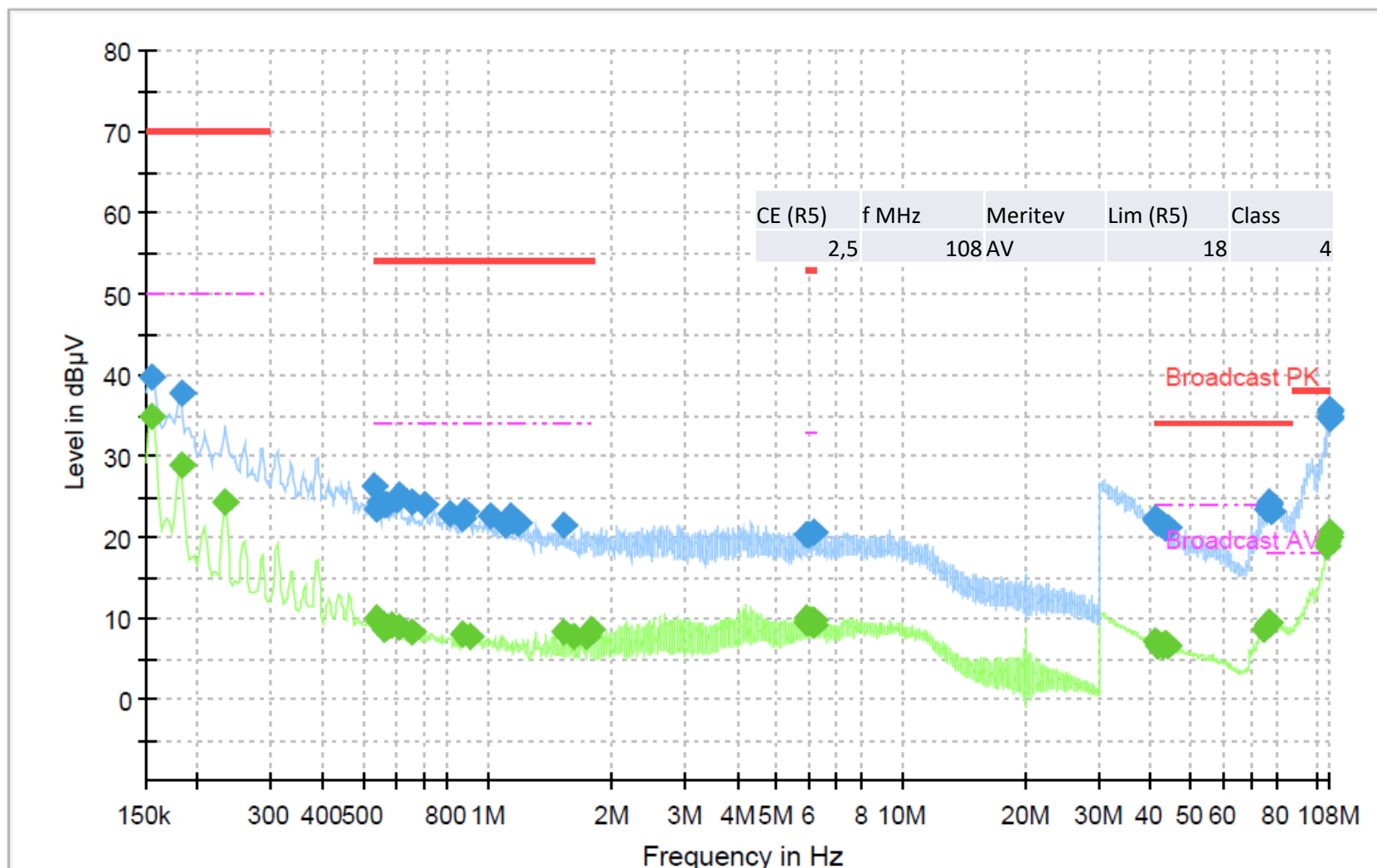

Žiga Šmelcer - VW

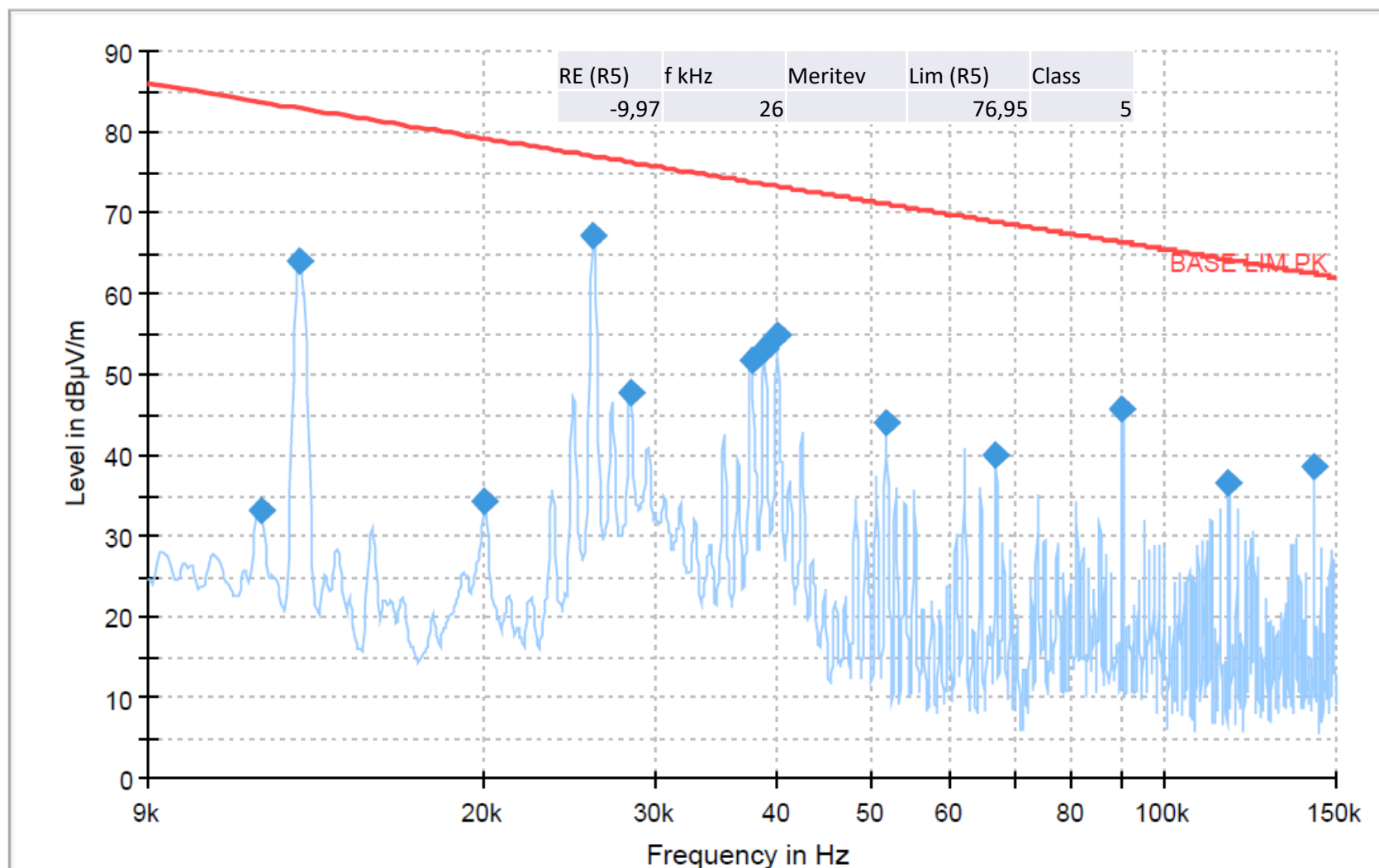

Žiga Šmelcer - RE

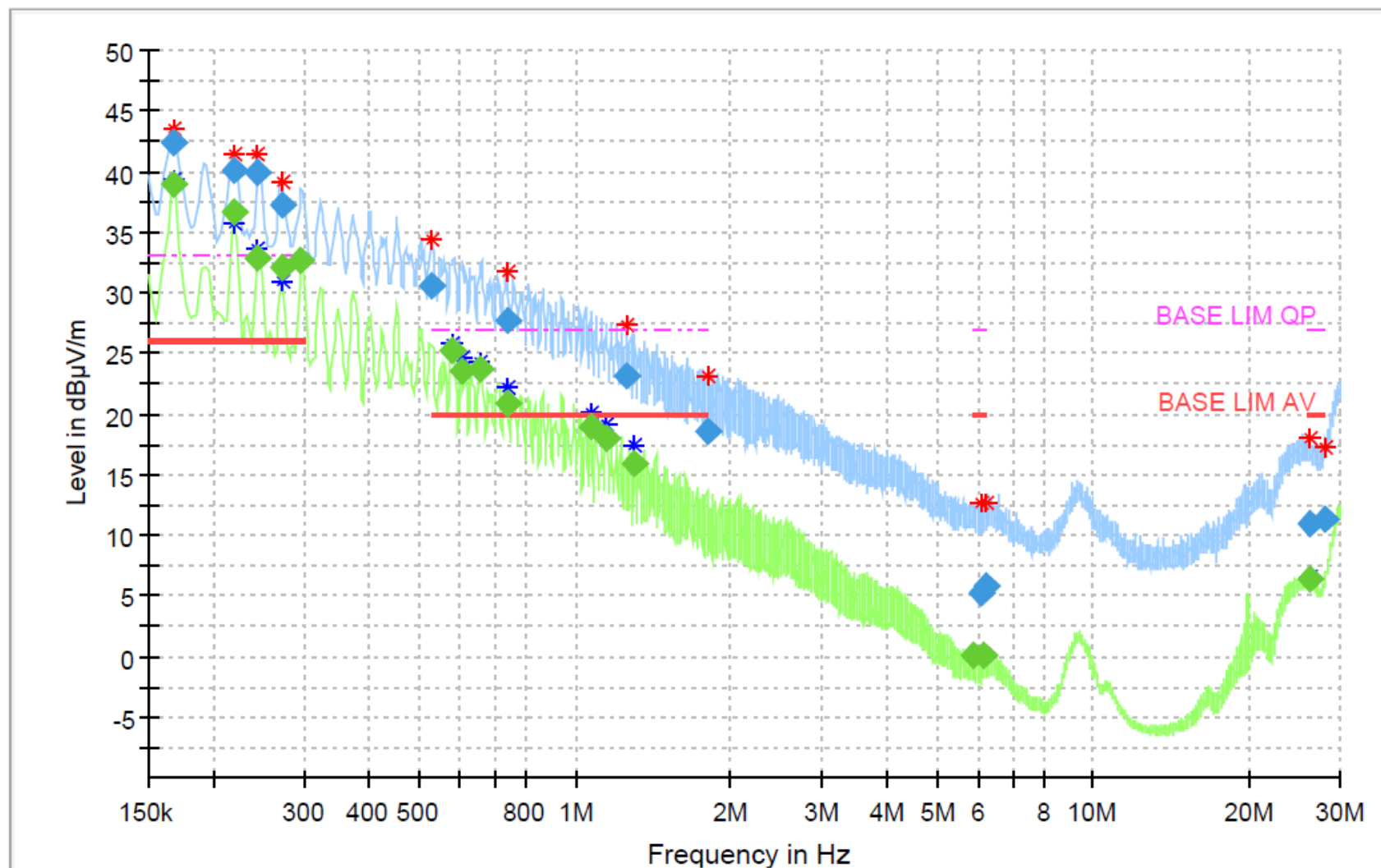

Žiga Šmelcer - RE

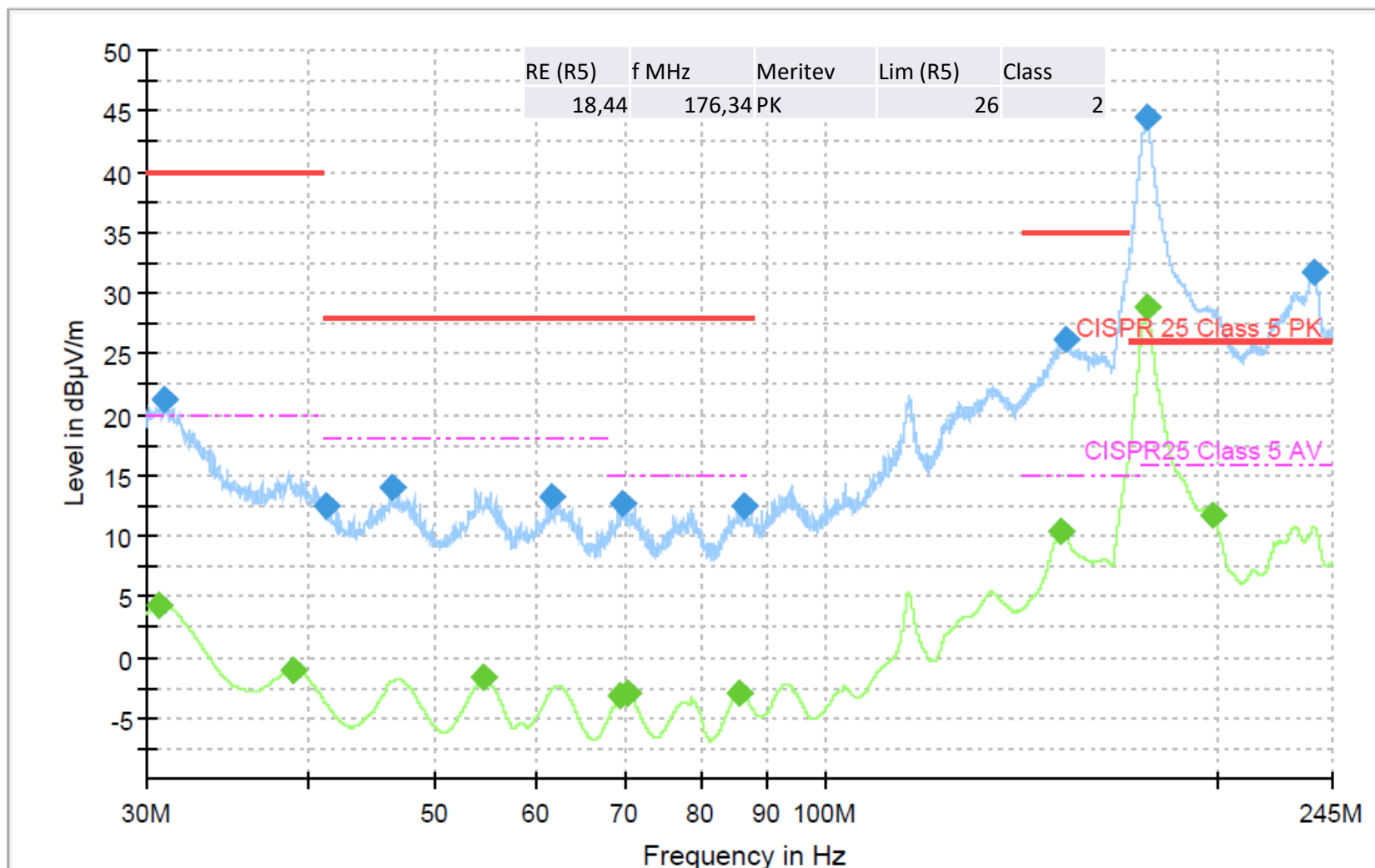



Laboratorij za fotovoltaiiko
in optoelektroniko



Laboratorij za
električne stroje



Laboratorij za regulacijsko tehniko in
močnostno elektroniko

KOLEKTOR



Povzetek rezultatov

Kdo bo po vašem mnenju zmagal?

by a guest · 17 hours ago

Jonas Oražem 26.92% (7 votes)

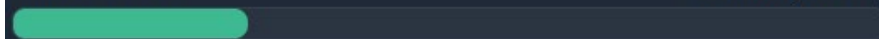

Luka Kavčič 19.23% (5 votes)

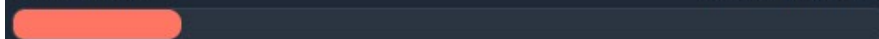

Matej Planinšek 15.38% (4 votes)

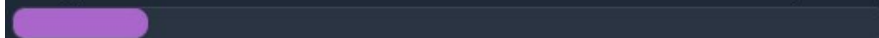

Žiga Šmelcer 11.54% (3 votes)

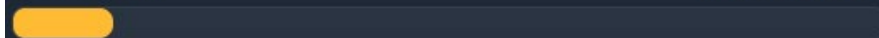

Jaša Vid Meh Peer 7.69% (2 votes)

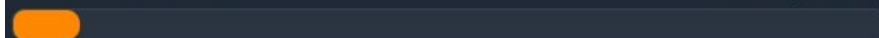

Luka Pogačnik 7.69% (2 votes)

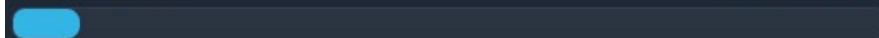

Tjaž Uran Oblak 7.69% (2 votes)

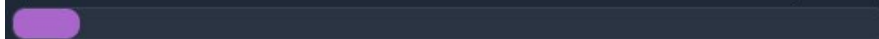

Maj Pavlin 3.85% (1 votes)

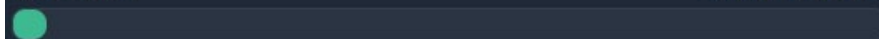

Jan Žagar 0% (0 votes)

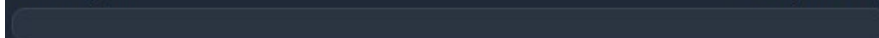

Žan Hedžet Kostanjšek 0% (0 votes)

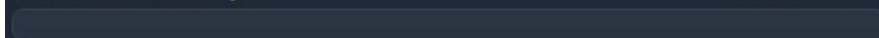

Total votes: 26

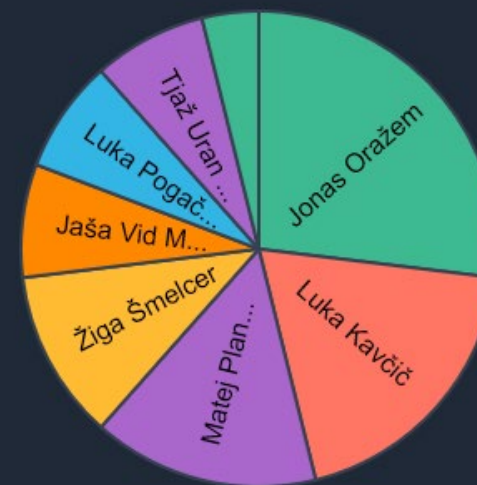

Povzetek rezultatov – BOM cene po komponentah

Tekmovalec	cena tranzistorjev	Cena kondenzatorjev	Cena dušilk	Cena diod	Skupaj
Žiga Šmelcer	0,87 €	0,53 €	0,51 €	0,02 €	1,93 €
Luka Kavčič	1,30 €	0,84 €	0,10 €	0,33 €	2,58 €
Maj Pavlin	2,24 €	0,47 €	0,07 €	0,01 €	2,80 €
Matej Planinšek	2,00 €	0,62 €	0,37 €	0,01 €	3,01 €
Jonas Oražem	2,04 €	1,10 €	0,10 €	0,01 €	3,25 €
Luka Pogačnik	0,80 €	2,43 €	0,72 €	0,02 €	3,96 €
Tjaž Uran Oblak	2,90 €	0,88 €	0,33 €	0,03 €	4,15 €
Žan Hedžet Kostanjšek	4,78 €	0,66 €	0,54 €	- €	5,98 €
Jan Žagar	1,58 €	1,81 €	2,78 €	0,19 €	6,36 €
Jaša Vid Meh Peer	2,15 €	4,17 €	0,58 €	0,06 €	6,96 €

Povzetek rezultatov - BOM

Tekmovalec	kvalifikacija	temp. območje	ostale zahteve	Cena komponent	Točke
Žiga Šmelcer	0	3	3	1,93 €	-3,65
Luka Kavčič	3	3	3	2,58 €	-3,9
Maj Pavlin	3	3	3	2,80 €	-5
Matej Planinšek	3	3	3	3,01 €	-6,05
Jonas Oražem	3	3	3	3,25 €	-7,25
Luka Pogačnik	3	3	3	3,96 €	-10,8
Tjaž Uran Oblak	3	3	3	4,15 €	-11,75
Jan Žagar	3	3	3	6,36 €	-22,8
Jaša Vid Meh Peer	3	3	3	6,96 €	-25,8
Žan Hedžet Kostanjšek	0	0	3	5,98 €	-26,9

Povzetek rezultatov - delovanje

Tekmovalec	Osnovna	Izkoristek	Polariteta	Padec r	Prenihaj	Točke
Jonas Oražem	12	13	5	5	5	40
Žiga Šmelcer	12	12	5	5	5	39
Matej Planinšek	12	10	5	5	5	37
Luka Kavčič	12	8	5	5	5	35
Jan Žagar	12	10	0	5	5	32
Maj Pavlin	12	10	0	5	5	32
Jaša Vid Meh Peer	12	8	5	5	0	30
Tjaž Uran Oblak	12	7	5	5	0	29
Žan Hedžet Kostanjšek	12	10	0	5	0	27
Luka Pogačnik	10	0	5	0	0	15

Povzetek rezultatov – CE 150kHz – 108 MHz

Tekmovalec	CE (R5)	f MHz	Meritev	Lim (R5)	Class	Lim (R)	Lim (R+1)	T(R)	T(R+1)	T+	T	↓
Jonas Oražem	-18,87	41,61	PK	34	5			35				35
Matej Planinšek	-5,99	0,15675	AV	50	5			35				35
Luka Pogačnik	-1,02	108	PK	38	5			35				35
Luka Kavčič	1,13	0,15475	AV	50	4	60	50	20	35	13		33
Žiga Šmelcer	2,5	108	AV	18	4	24	18	20	35	9		29
Tjaž Uran Oblak	5,44	0,1815	AV	50	4	60	26	20	35	2		22
Maj Pavlin	12,62	0,15675	AV	50	3	70	60	10	20	7		17
Jaša Vid Meh Peer	8,23	51,3	PK	34	3	46	40	10	20	6		16
Jan Žagar	14,25	0,1545	AV	50	3	70	60	10	20	6		16
Žan Hedžet Kostanjšek	12,37	108	PK	38	2	56	50	5	10	5		10

Povzetek rezultatov – VW RE 9kHz – 150 kHz

Tekmovalec	RE (R5)	f kHz	Meritev	Lim (R5)	Class	T
Jonas Oražem	-19,25	26		76,95	5	9
Matej Planinšek	-12,32	26		76,95	5	9
Luka Kavčič	-12,07	26		76,95	5	9
Žiga Šmelcer	-9,97	26		76,95	5	9
Tjaž Uran Oblak	-9,27	26		76,95	5	9
Jaša Vid Meh Peer	-8,46	26		76,95	5	9
Luka Pogačnik	-5,1	45		76,95	5	9
Jan Žagar	-2,51	26		76,95	5	9
Žan Hedžet Kostanjšek	-1,98	26		76,95	5	9
Maj Pavlin	4,6	26		76,95	4	6

Povzetek rezultatov – RE 150 kHz – 245 MHz

Tekmovalec	RE (R5)	f MHz	Meritev	Lim (R5)	Class	Lim (R)	Lim (R+1)	T(R)	T(R+1)	T+	T
Tjaž Uran Oblak	12,28	0,17	AV	26	3	46	36	10	20	8	18
Jaša Vid Meh Peer	14,82	0,168	AV	26	3	46	36	10	20	5	15
Luka Kavčič	16,41	0,168	AV	26	3	46	36	10	20	4	14
Žan Hedžet Kostanjšek	16,67	0,17	AV	26	3	46	36	10	20	3	13
Matej Planinšek	15,31	0,17	AV	26	3	46	36	10			10
Jonas Oražem	15,67	0,168	AV	26	3	46	36	10			10
Jan Žagar	25,55	0,154	AV	26	2	56	46	5	10	2	7
Žiga Šmelcer	18,44	176,34	PK	26	2	44	38	5	10	0	5
Maj Pavlin	33,74	0,168	AV	26	1	66	56	0	5	3	3
Luka Pogačnik	28,72	176,13	PK	26	0		50	0	0	-5	-5



Laboratorij za fotovoltaiiko
in optoelektroniko



Laboratorij za
električne stroje



Laboratorij za regulacijsko tehniko in
močnostno elektroniko

KOLEKTOR



Razglasitev rezultatov in podelitev nagrad

1. mesto – Luka Kavčič

Tekmovalec	BOM	Delovanje	CE	RE	VW RE	Vsota	Mesto
Luka Kavčič	-3,9	35,0	33,3	13,6	9,0	87,0	1

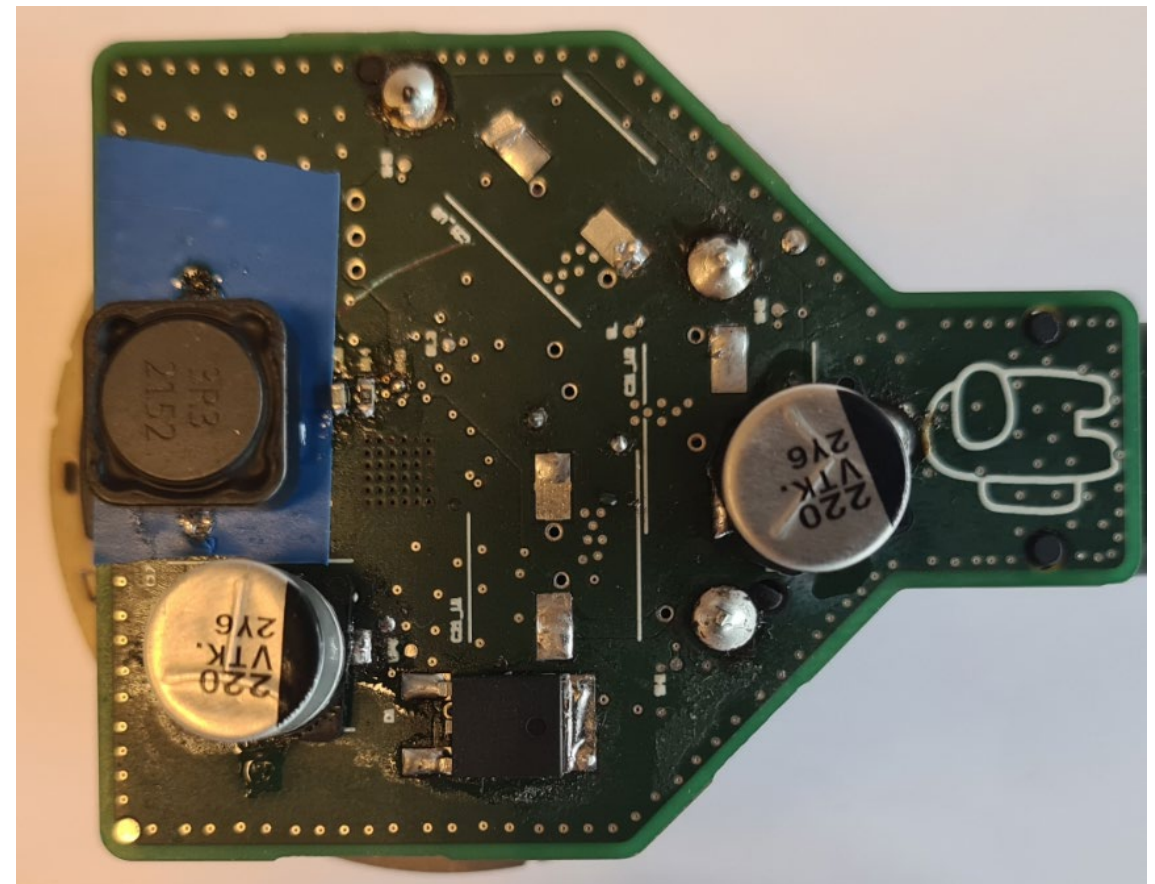
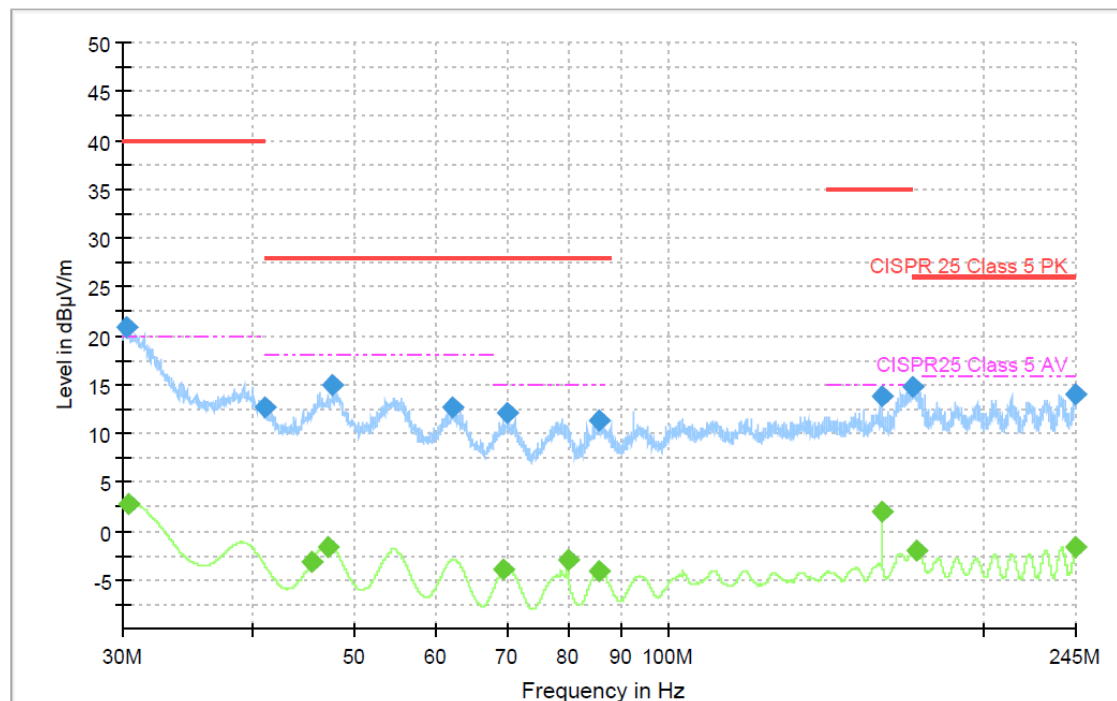

Nagrade

Podjetje	Nagrada
Kolektor	Denarna nagrada (2000 €)
Mahle EDS	Denarna nagrada (1000 €)
Forvia - Hella Saturnus	Denarna nagrada (700 €)
Instrumentation technologies	Red pitaya STEM-lab (550 €)
GEM motors	Denarna nagrada (500 €)
SIQ	2 uri meritev v EMC komori in tehnično darilo (500 €)
Amiteh	Osciloskop Rigol DS1054Z (354 €)
Goap	Denarna nagrada (300 €)
Iskra emeco	Denarna nagrada (200 €)
Würth elektronik	Doživljenjski free-refill design kit po izbiri (~ 200€)

2. mesto – Jonas Oražem

Tekmovalec	BOM	Delovanje	CE	RE	VW RE	Vsota	Mesto
Jonas Oražem	-7,3	40,0	35,0	10,0	9,0	86,8	2

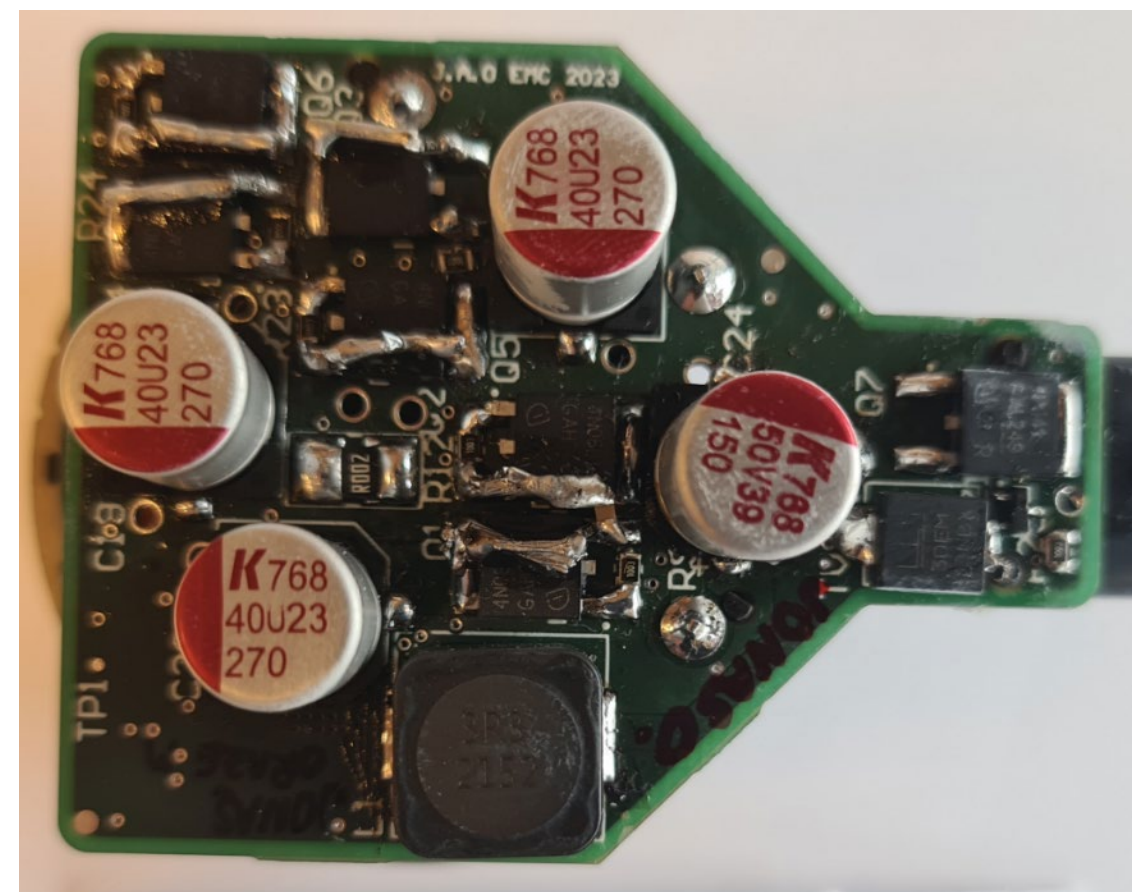
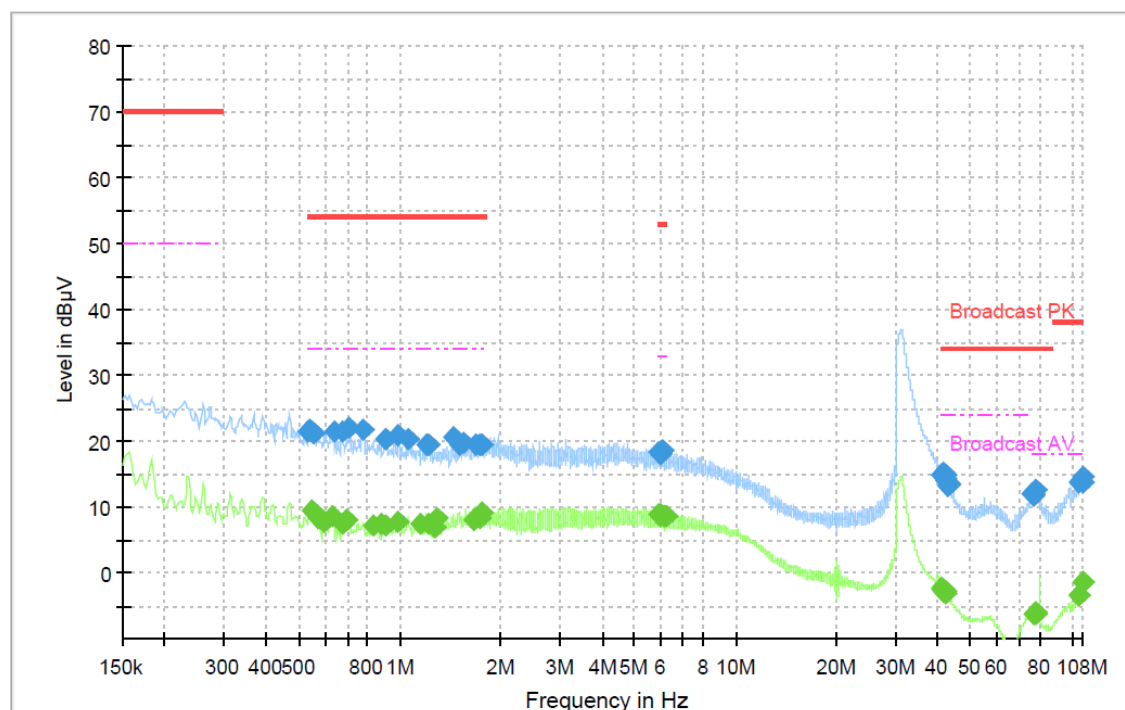

Nagrade

Podjetje	Nagrada
Kolektor	Denarna nagrada (2000 €)
Mahle EDS	Denarna nagrada (1000 €)
Forvia - Hella Saturnus	Denarna nagrada (700 €)
Instrumentation technologies	Red pitaya STEM-lab (550 €)
GEM motors	Denarna nagrada (500 €)
SIQ	2 uri meritev v EMC komori in tehnično darilo (500 €)
Amiteh	Osciloskop Rigol DS1054Z (354 €)
Goap	Denarna nagrada (300 €)
Iskra emeco	Denarna nagrada (200 €)
Würth elektronik	Doživljenjski free-refill design kit po izbiri (~200€)

3. mesto – Matej Planinšek

Tekmovalec	BOM	Delovanje	CE	RE	VW RE	Vsota	Mesto
Matej Planinšek	-6,05	37,0	35,0	10,0	9,0	85,0	3

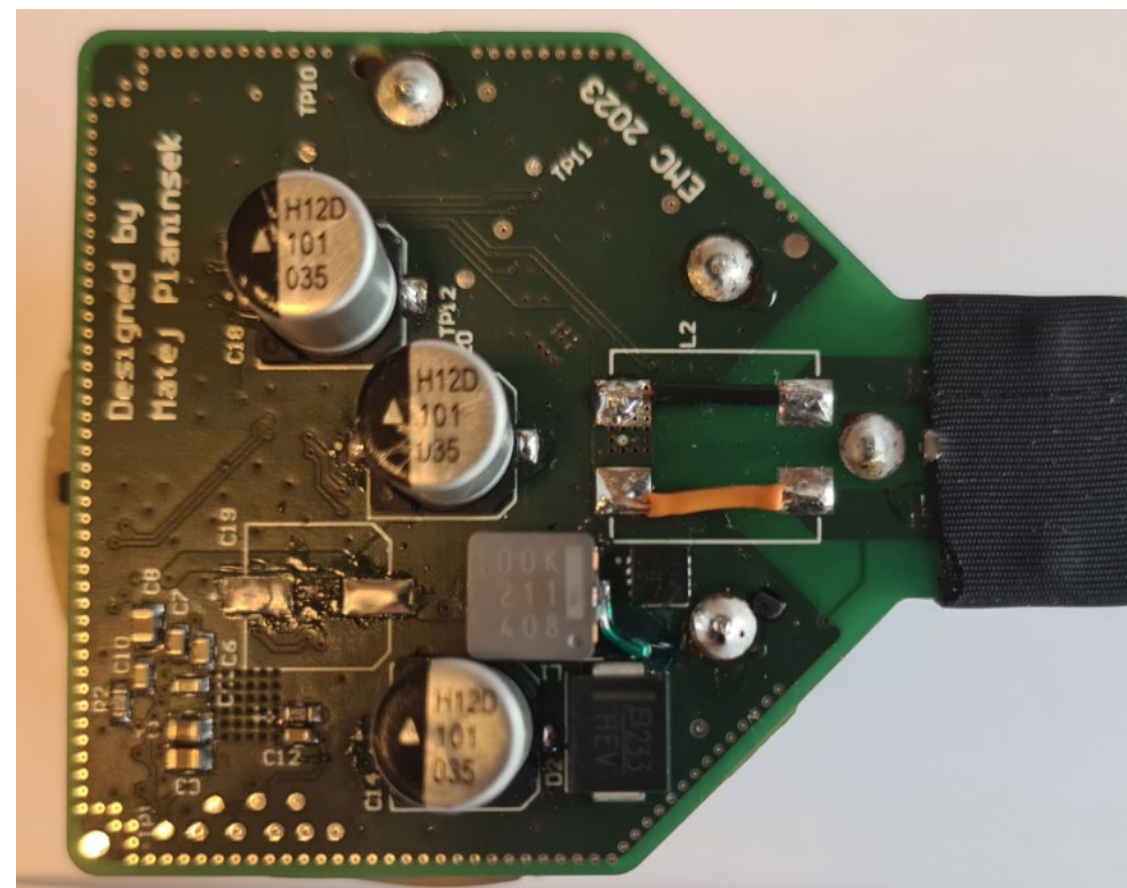
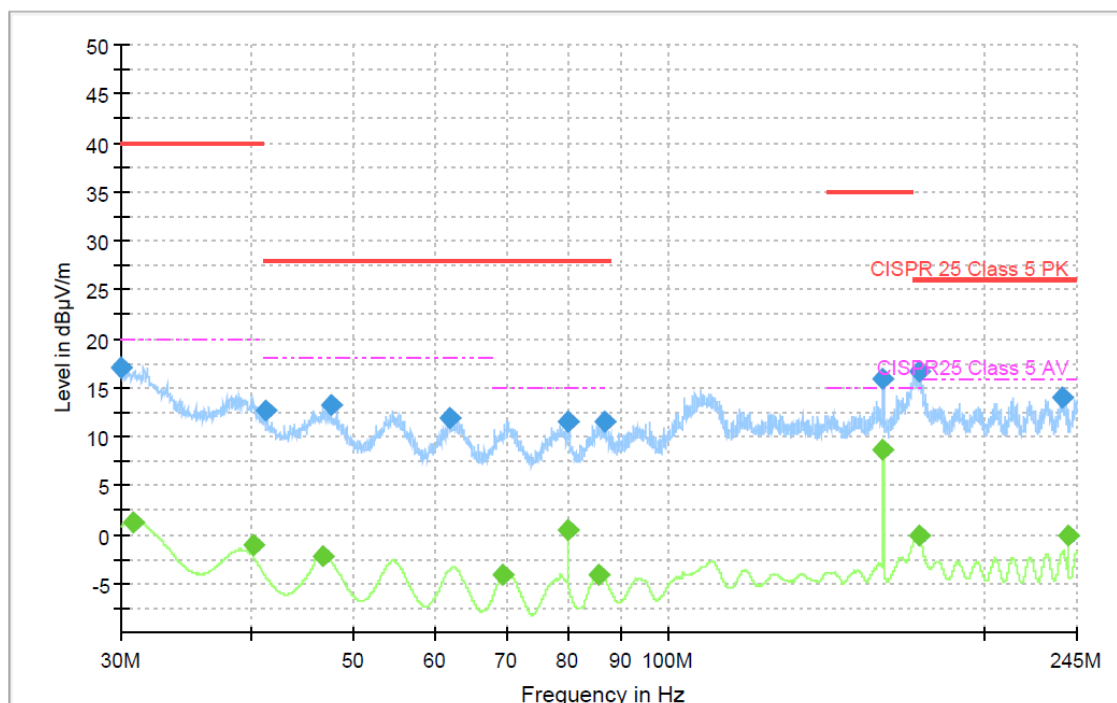

Nagrade

Podjetje	Nagrada
Kolektor	Denarna nagrada (2000 €)
Mahle EDS	Denarna nagrada (1000 €)
Forvia - Hella Saturnus	Denarna nagrada (700 €)
Instrumentation technologies	Red pitaya STEM-lab (550 €)
GEM motors	Denarna nagrada (500 €)
SIQ	2 uri meritev v EMC komori in tehnično darilo (500 €)
Amiteh	Osciloskop Rigol DS1054Z (354 €)
Goap	Denarna nagrada (300 €)
Iskra emeco	Denarna nagrada (200 €)
Würth elektronik	Doživljenjski free-refill design kit po izbiri (~ 200€)

4. mesto – Žiga Šmelcer

Tekmovalec	BOM	Delovanje	CE	RE	VW RE	Vsota	Mesto
Žiga Šmelcer	-3,65	39,0	28,8	4,6	9,0	77,7	4

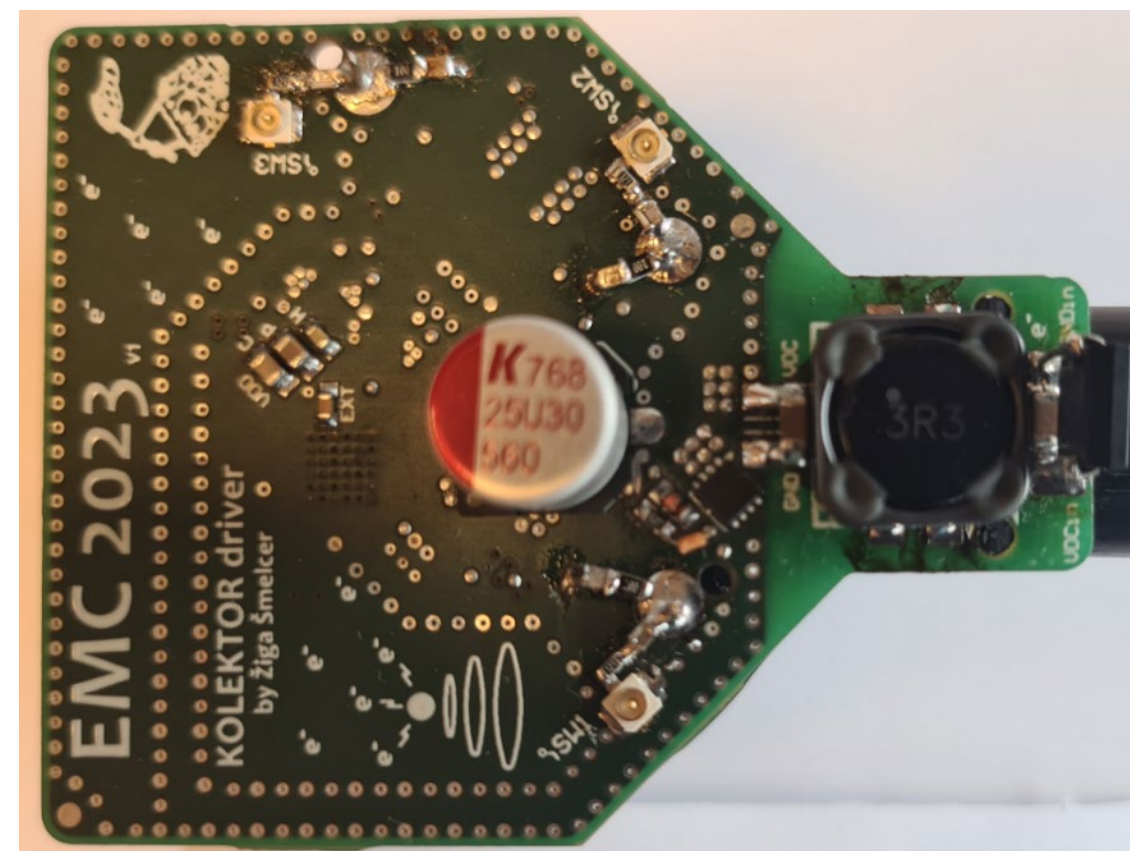
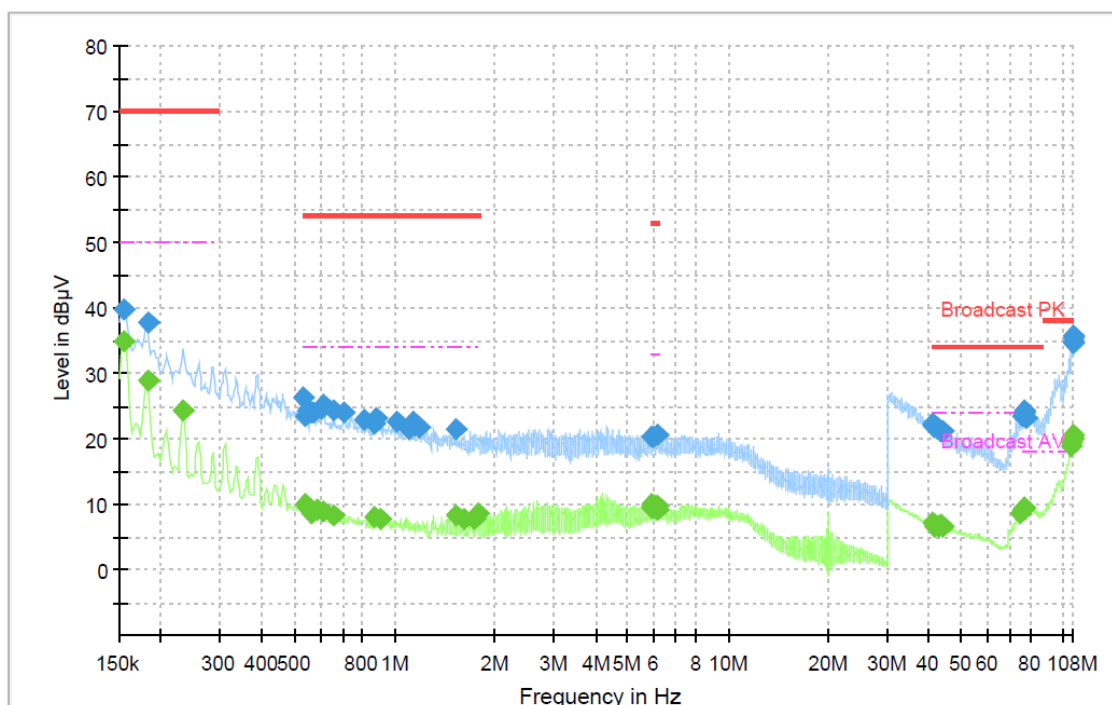

Nagrade

Podjetje	Nagrada
Kolektor	Denarna nagrada (2000 €)
Mahle EDS	Denarna nagrada (1000 €)
Forvia - Hella Saturnus	Denarna nagrada (700 €)
Instrumentation technologies	Red pitaya STEM-lab (550 €)
GEM motors	Denarna nagrada (500 €)
SIQ	2 uri meritev v EMC komori in tehnično darilo (500 €)
Amiteh	Osciloskop Rigol DS1054Z (354 €)
Goap	Denarna nagrada (300 €)
Iskra emeco	Denarna nagrada (200 €)
Würth elektronik	Doživljenjski free-refill design kit po izbiri (~ 200€)

5. mesto – Tjaž Uran Oblak

Tekmovalec	BOM	Delovanje	CE	RE	VW RE	Vsota	Mesto
Tjaž Uran Oblak	-11,8	29,0	22,0	17,7	9,0	66,0	5

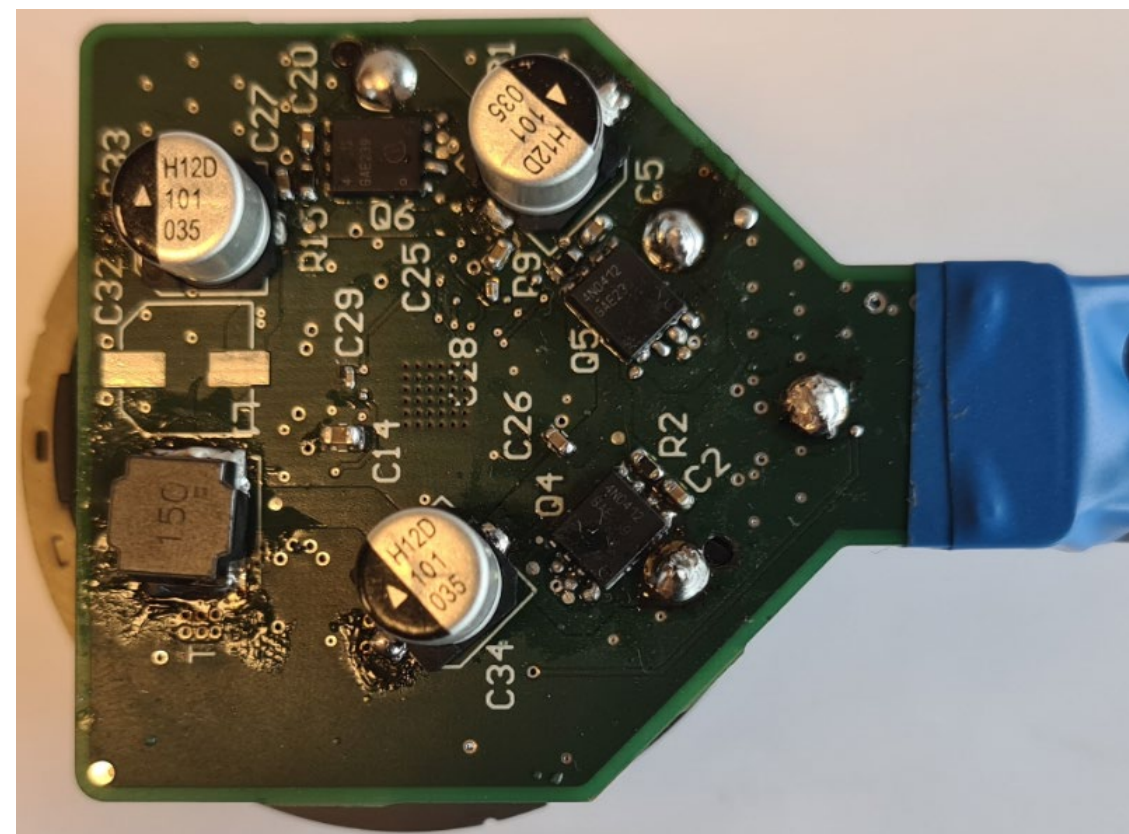
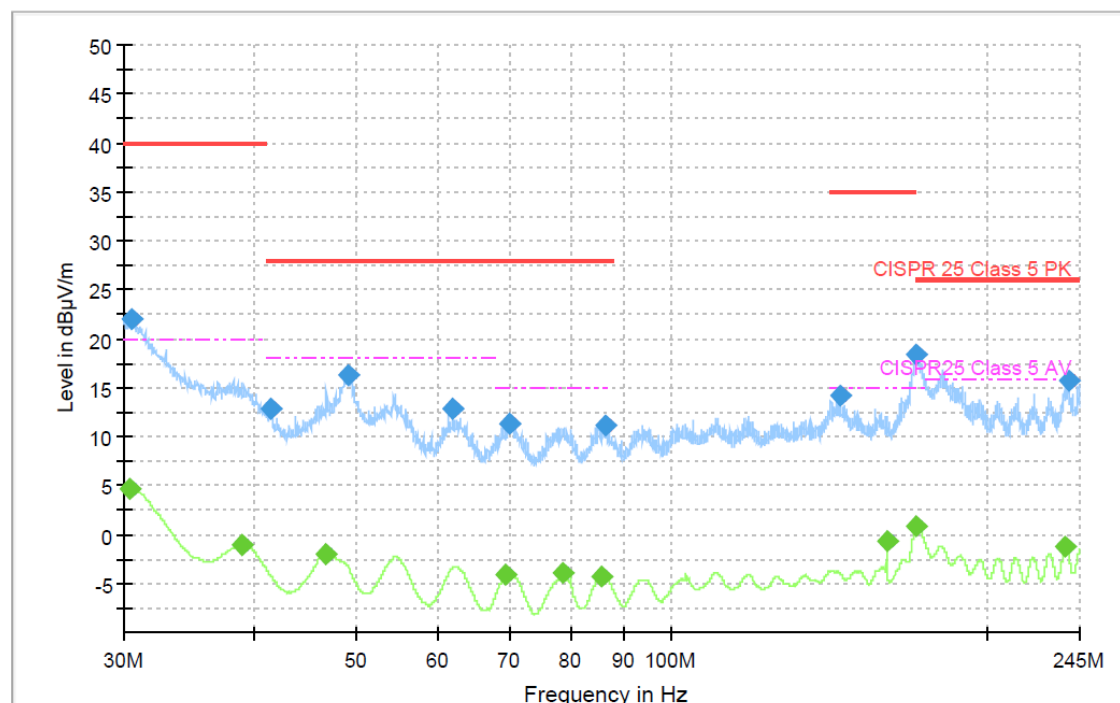

Nagrade

Podjetje	Nagrada
Kolektor	Denarna nagrada (2000 €)
Mahle EDS	Denarna nagrada (1000 €)
Forvia - Hella Saturnus	Denarna nagrada (700 €)
Instrumentation technologies	Red pitaya STEM-lab (550 €)
GEM motors	Denarna nagrada (500 €)
SIQ	2 uri meritev v EMC komori in tehnično darilo (500 €)
Amiteh	Osciloskop Rigol DS1054Z (354 €)
Goap	Denarna nagrada (300 €)
Iskra emeco	Denarna nagrada (200 €)
Würth elektronik	Doživljenjski free-refill design kit po izbiri (~ 200€)

6. mesto – Maj Pavlin

Tekmovalec	BOM	Delovanje	CE	RE	VW RE	Vsota	Mesto
Maj Pavlin	-5,0	32,0	17,4	3,1	6,0	53,5	6

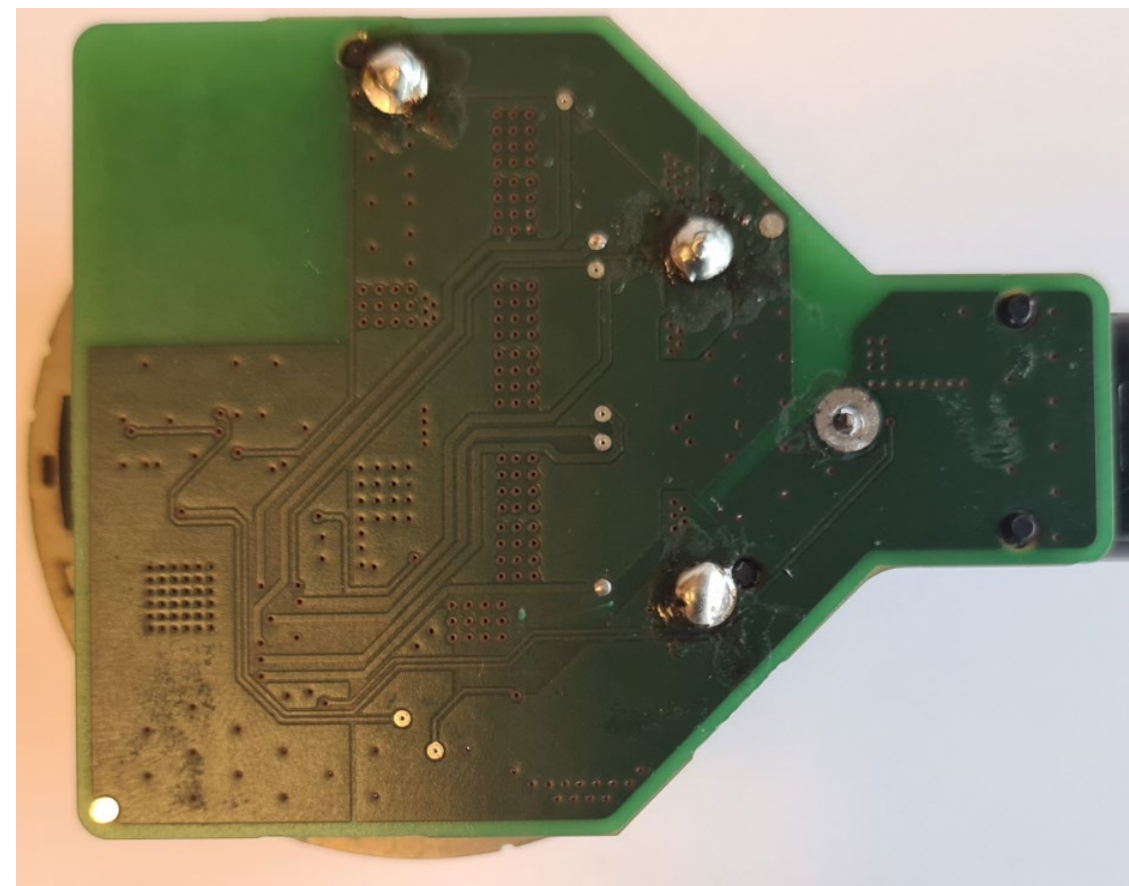
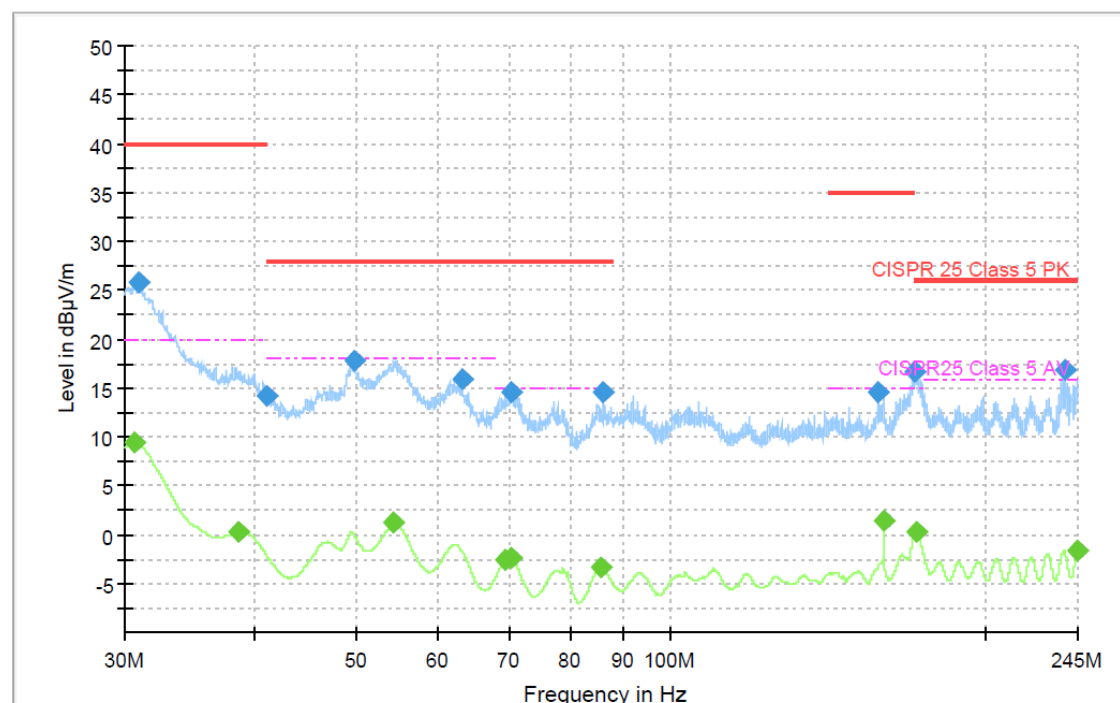

Nagrade

Podjetje	Nagrada
Kolektor	Denarna nagrada (2000 €)
Mahle EDS	Denarna nagrada (1000 €)
Forvia - Hella Saturnus	Denarna nagrada (700 €)
Instrumentation technologies	Red pitaya STEM-lab (550 €)
GEM motors	Denarna nagrada (500 €)
SIQ	2 uri meritev v EMC komori in tehnično darilo (500 €)
Amiteh	Osciloskop Rigol DS1054Z (354 €)
Goap	Denarna nagrada (300 €)
Iskra emeco	Denarna nagrada (200 €)
Würth elektronik	Doživljenjski free-refill design kit po izbiri (~ 200€)

7. mesto – Jaša Vid Meh Peer

Tekmovalec	BOM	Delovanje	CE	RE	VW RE	Vsota	Mesto
Jaša Vid Meh Peer	-25,8	30,0	16,3	15,2	9,0	44,7	7

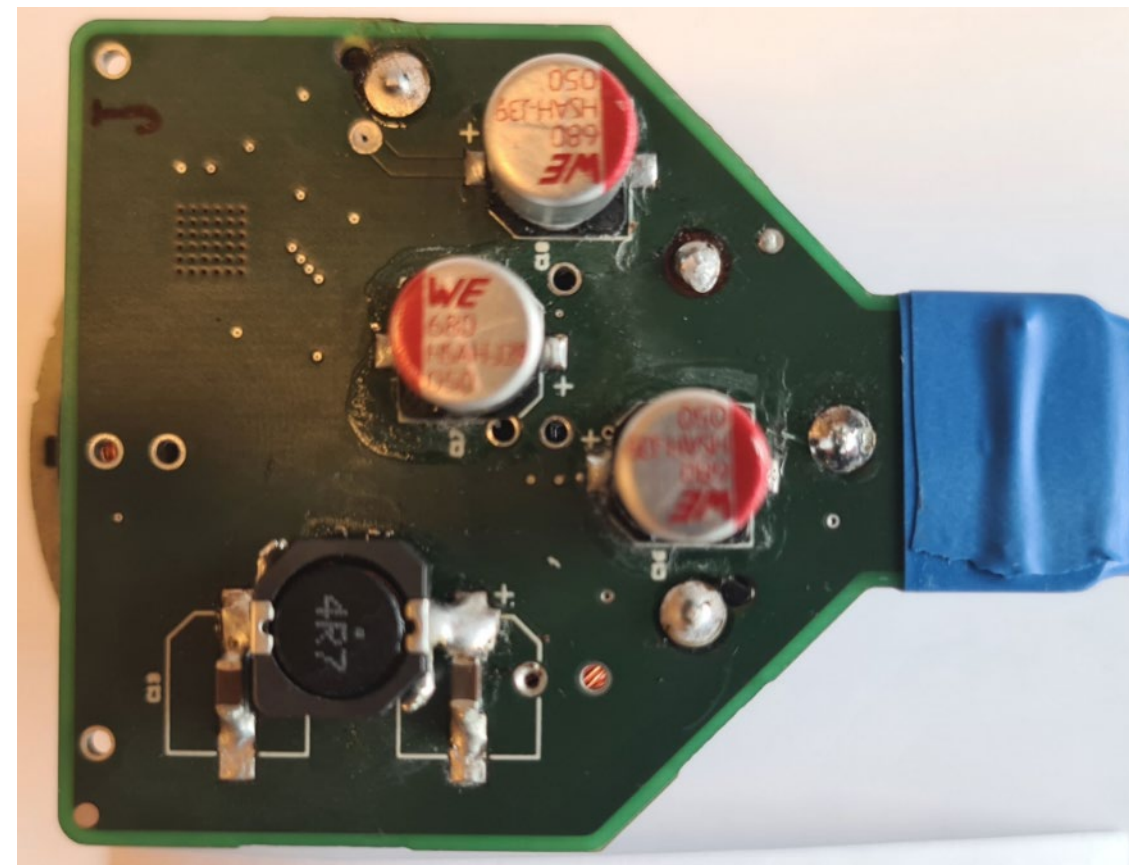
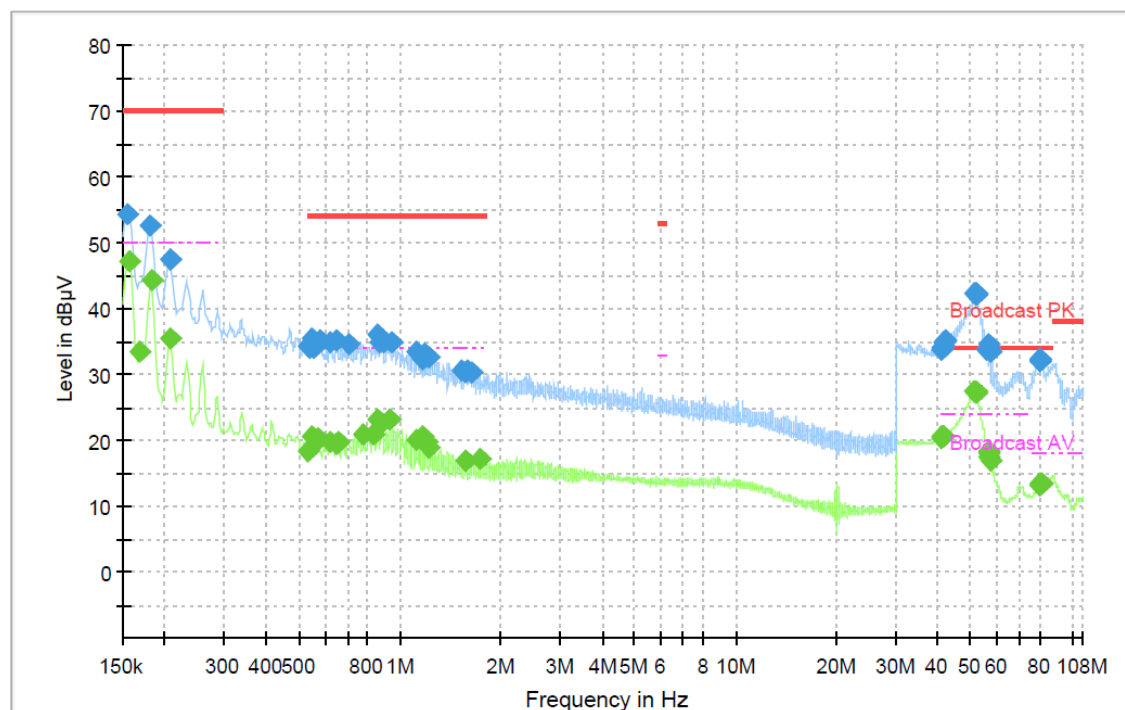

Nagrade

Podjetje	Nagrada
Kolektor	Denarna nagrada (2000 €)
Mahle EDS	Denarna nagrada (1000 €)
Forvia - Hella Saturnus	Denarna nagrada (700 €)
Instrumentation technologies	Red pitaya STEM-lab (550 €)
GEM motors	Denarna nagrada (500 €)
SIQ	2 uri meritev v EMC komori in tehnično darilo (500 €)
Amiteh	Osciloskop Rigol DS1054Z (354 €)
Goap	Denarna nagrada (300 €)
Iskra emeco	Denarna nagrada (200 €)
Wurth elektronik	Doživljenjski free-refill design kit po izbiri (~ 200€)

8. mesto – Luka Pogačnik

Tekmovalec	BOM	Delovanje	CE	RE	VW RE	Vsota	Mesto
Luka Pogačnik	-10,8	15,0	35,0	-4,7	9,0	43,5	8

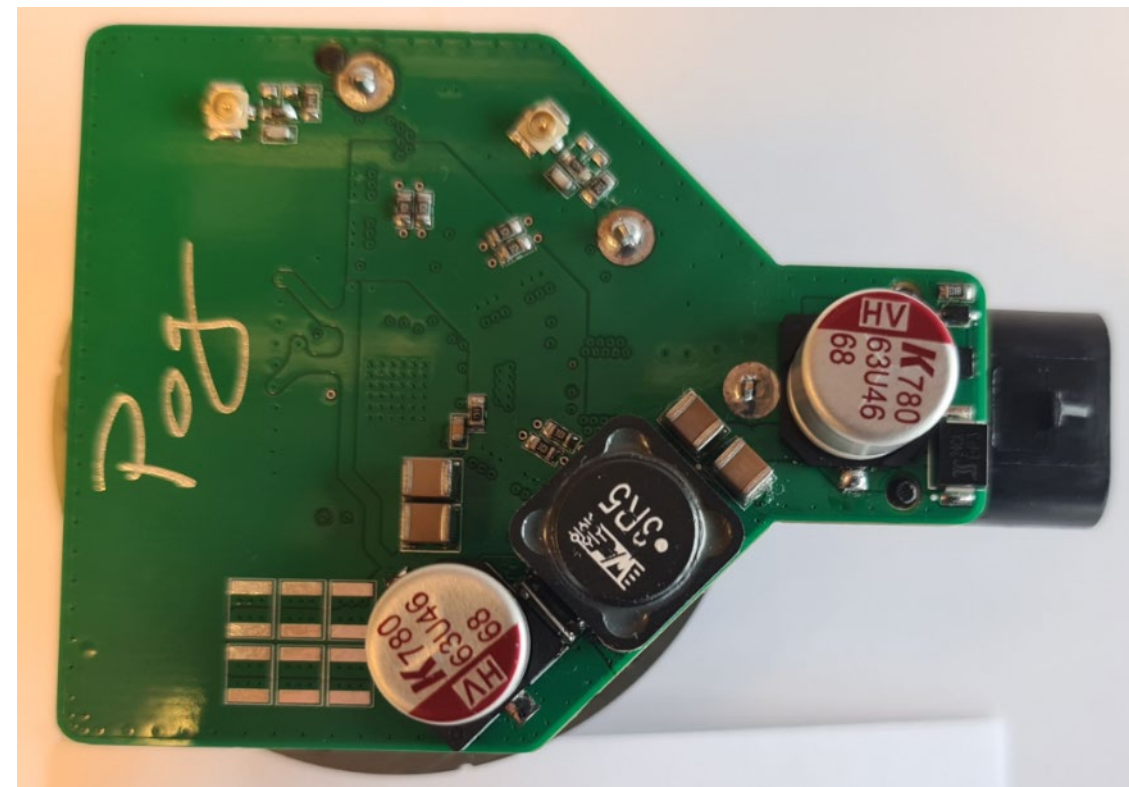
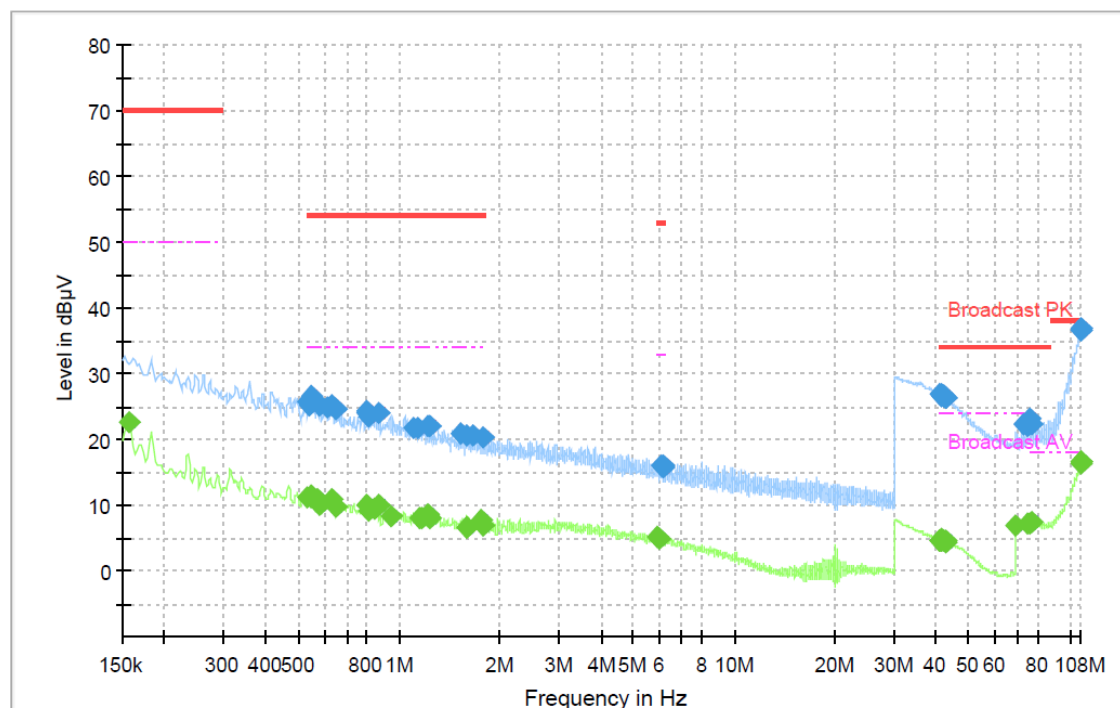

Nagrade

Podjetje	Nagrada
Kolektor	Denarna nagrada (2000 €)
Mahle EDS	Denarna nagrada (1000 €)
Forvia - Hella Saturnus	Denarna nagrada (700 €)
Instrumentation technologies	Red pitaya STEM-lab (550 €)
GEM motors	Denarna nagrada (500 €)
SIQ	2 uri meritev v EMC komori in tehnično darilo (500 €)
Amiteh	Osciloskop Rigol DS1054Z (354 €)
Goap	Denarna nagrada (300 €)
Iskra emeco	Denarna nagrada (200 €)
Würth elektronik	Doživljenjski free-refill design kit po izbiri (~ 200€)

9. mesto – Jan Žagar

Tekmovalec	BOM	Delovanje	CE	RE	VW RE	Vsota	Mesto
Jan Žagar	-22,8	32,0	15,8	7,2	9,0	41,2	9

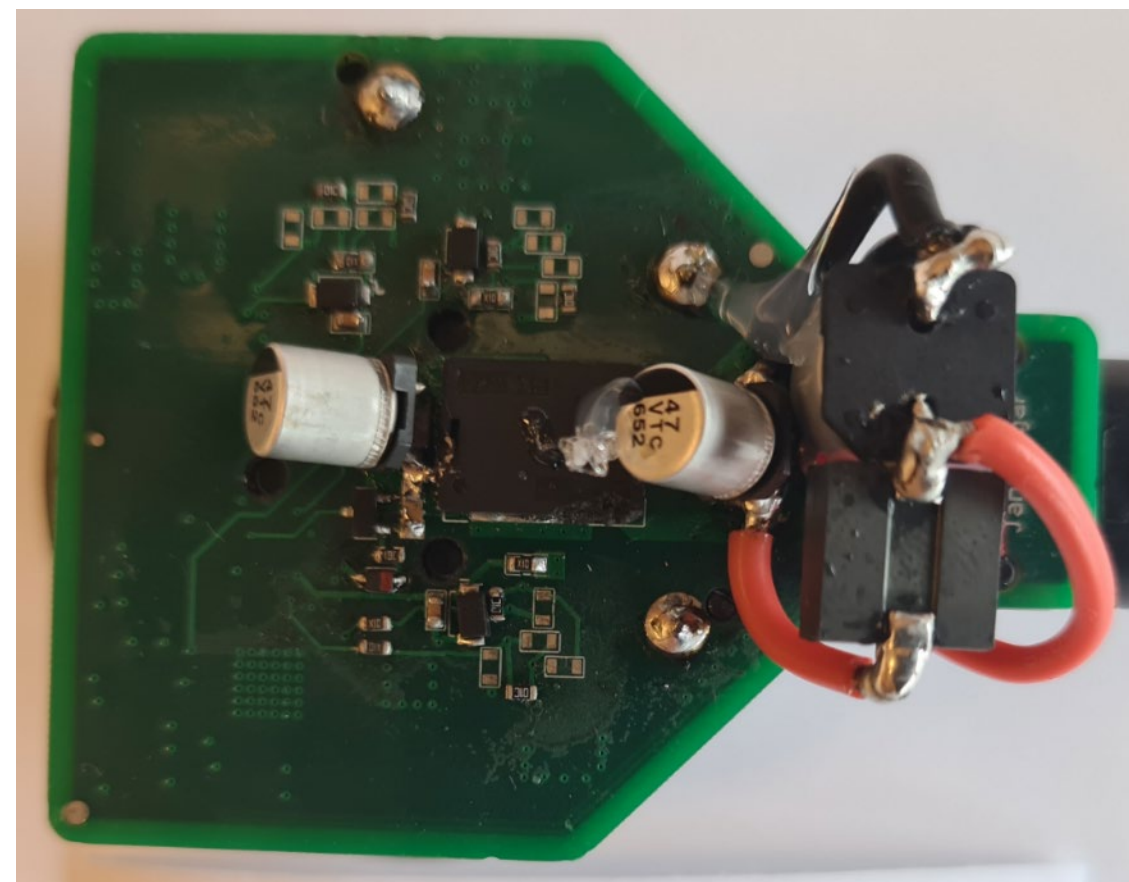
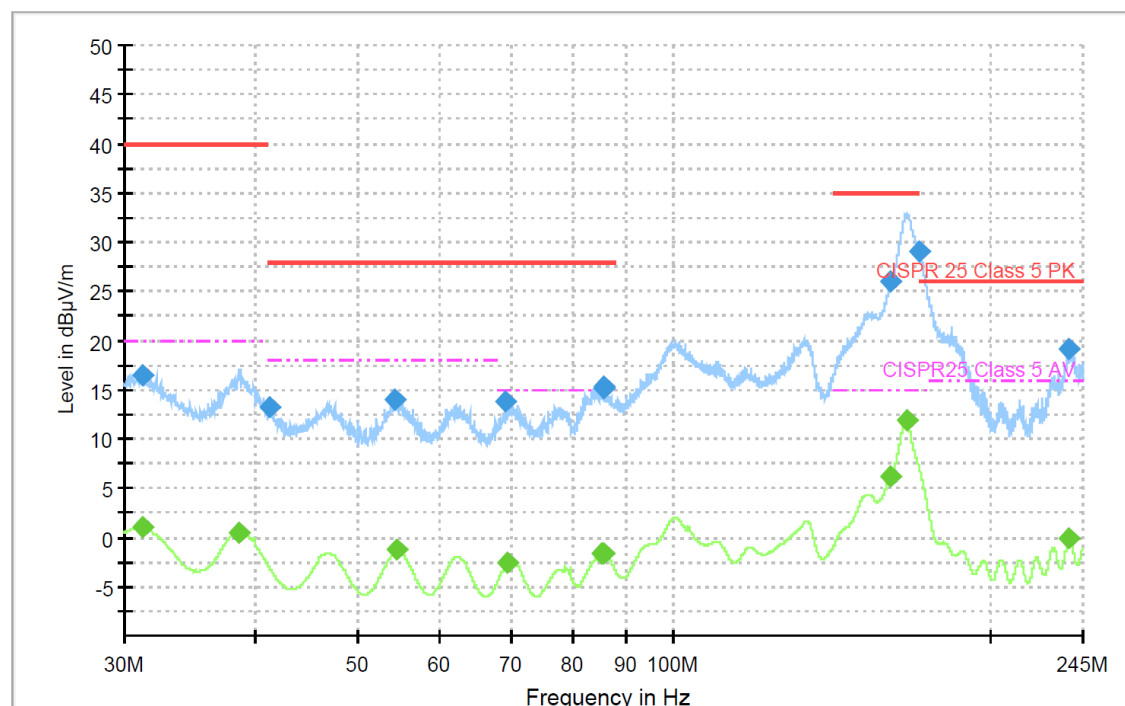

Nagrade

Podjetje	Nagrada
Kolektor	Denarna nagrada (2000 €)
Mahle EDS	Denarna nagrada (1000 €)
Forvia - Hella Saturnus	Denarna nagrada (700 €)
Instrumentation technologies	Red pitaya STEM-lab (550 €)
GEM motors	Denarna nagrada (500 €)
SIQ	2 uri meritev v EMC komori in tehnično darilo (500 €)
Amiteh	Osciloskop Rigol DS1054Z (354 €)
Goap	Denarna nagrada (300 €)
Iskra emeco	Denarna nagrada (200 €)
Würth elektronik	Doživljenjski free-refill design kit po izbiri (~ 200€)

10. mesto – Žan Hedžet Kostanjšek

Tekmovalec	BOM	Delovanje	CE	RE	VW RE	Vsota	Mesto
Žan Hedžet Kostanjšek	-26,9	27,0	9,7	13,3	9,0	32,1	10

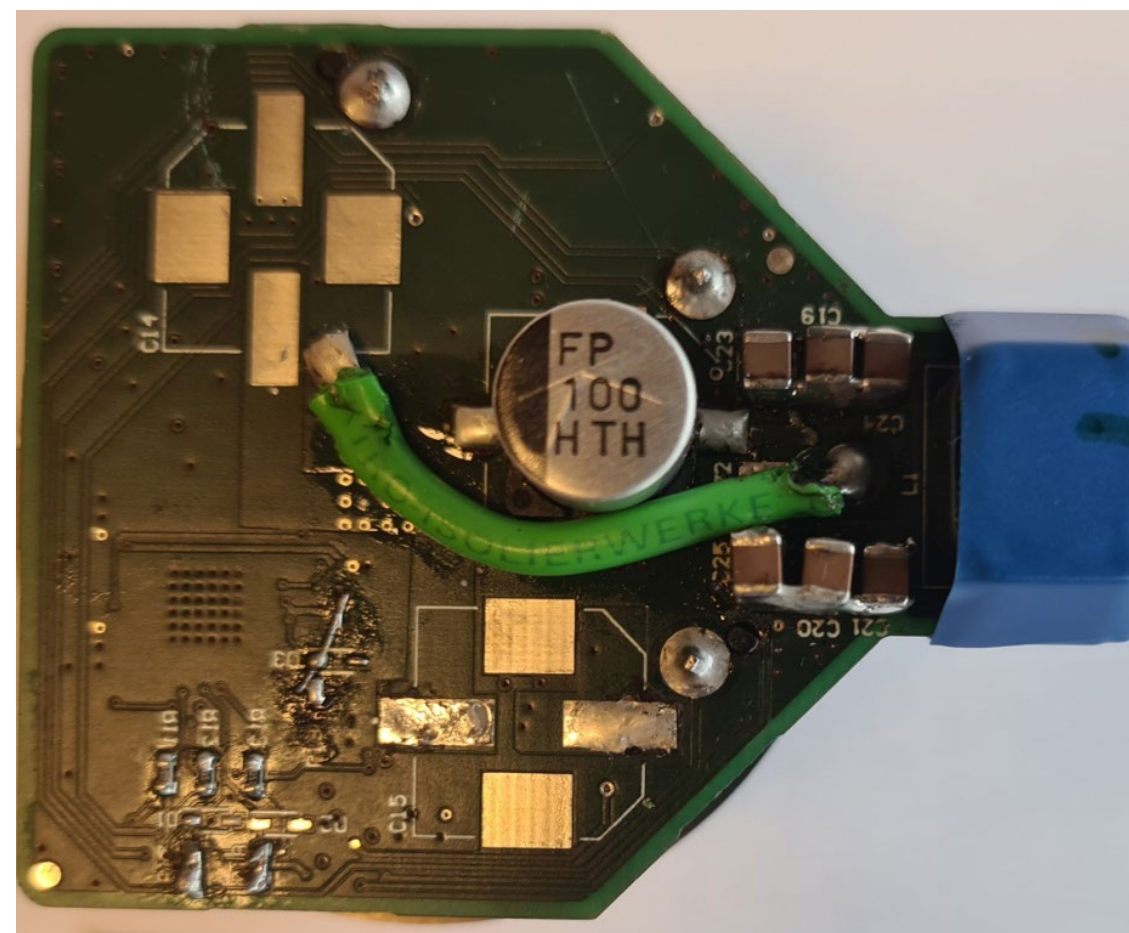
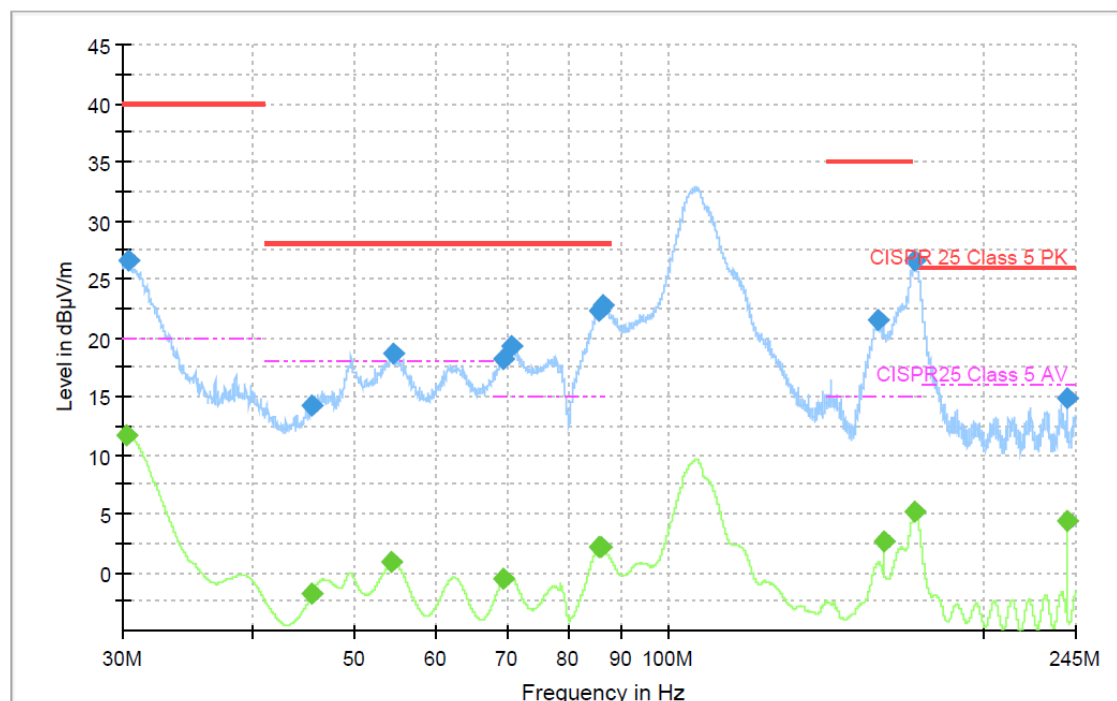

Nagrade

Podjetje	Nagrada
Kolektor	Denarna nagrada (2000 €)
Mahle EDS	Denarna nagrada (1000 €)
Forvia - Hella Saturnus	Denarna nagrada (700 €)
Instrumentation technologies	Red pitaya STEM-lab (550 €)
GEM motors	Denarna nagrada (500 €)
SIQ	2 uri meritev v EMC komori in tehnično darilo (500 €)
Amiteh	Osciloskop Rigol DS1054Z (354 €)
Goap	Denarna nagrada (300 €)
Iskra emeco	Denarna nagrada (200 €)
Würth elektronik	Doživljenjski free-refill design kit po izbiri (~ 200€)

Končni rezultati



Tekmovalec	BOM	Delovanje	CE	RE	VW RE	Vsota	Mesto
Luka Kavčič	-3,90	35,0	33,3	13,6	9,0	87,0	1
Jonas Oražem	-7,25	40,0	35,0	10,0	9,0	86,8	2
Matej Planinšek	-6,05	37,0	35,0	10,0	9,0	85,0	3
Žiga Šmelcer	-3,65	39,0	28,8	4,6	9,0	77,7	4
Tjaž Uran Oblak	-11,75	29,0	22,0	17,7	9,0	66,0	5
Maj Pavlin	-5,00	32,0	17,4	3,1	6,0	53,5	6
Jaša Vid Meh Peer	-25,80	30,0	16,3	15,2	9,0	44,7	7
Luka Pogačnik	-10,80	15,0	35,0	-4,7	9,0	43,5	8
Jan Žagar	-22,80	32,0	15,8	7,2	9,0	41,2	9
Žan Hedžet Kostanjšek	-26,90	27,0	9,7	13,3	9,0	32,1	10

Načrtovanje elektronike za EMC



študentska delavnica in tekmovanje

NAGRADNI SKLAD >6000 EUR



Laboratorij za fotovoltaiko
in optoelektroniko



Laboratorij za
električne stroje



Laboratorij za regulacijsko tehniko in
močnostno elektroniko

KOLEKTOR

