

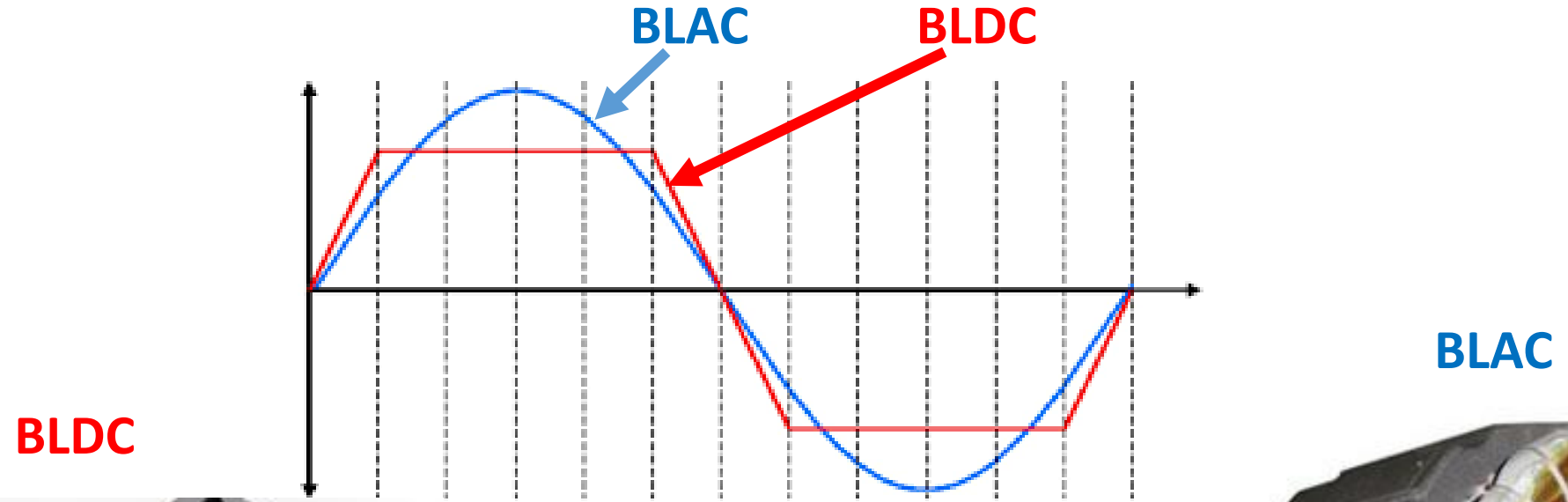

Elektronsko komutirani motorji

Prof. dr. Damijan Miljavec

Inducirana napetost



Vodenje BLDC in BLAC

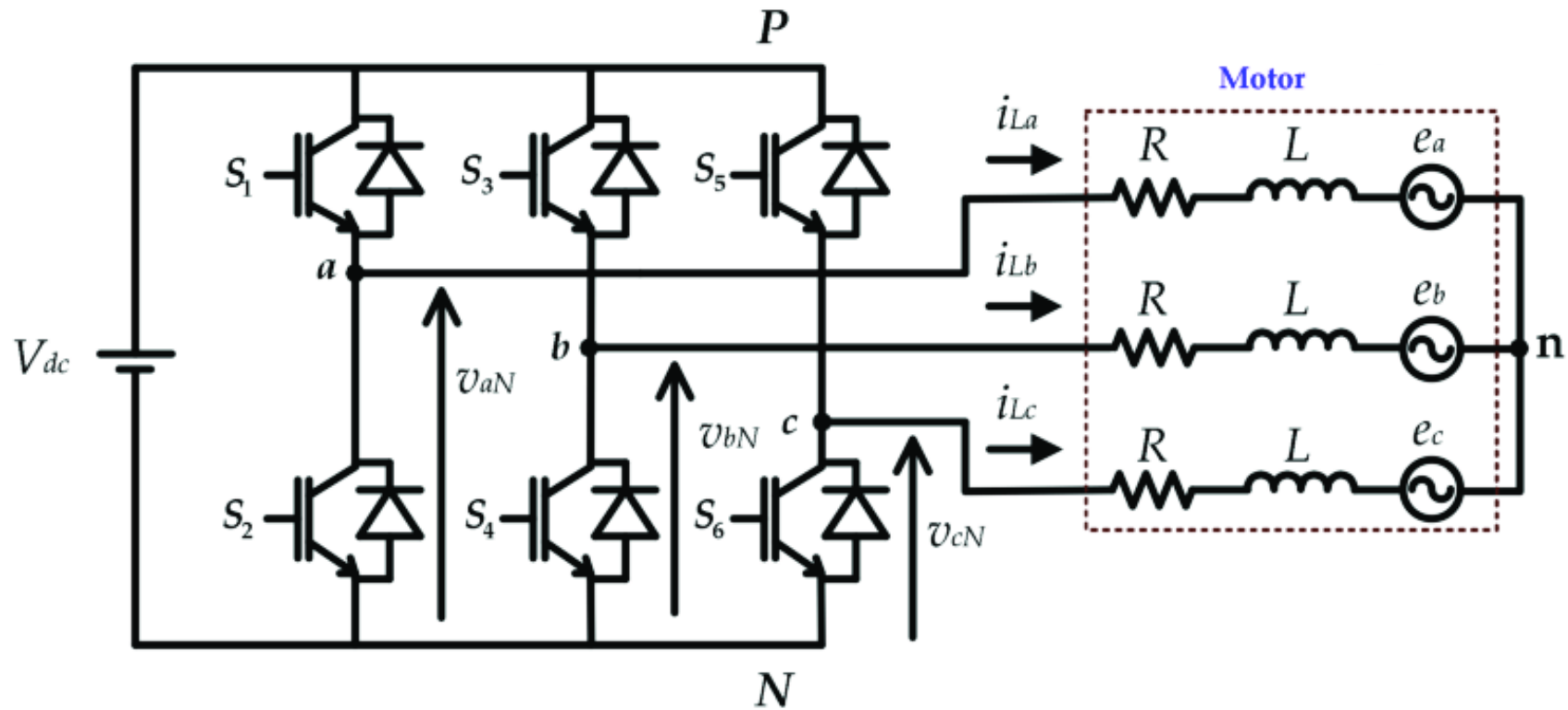

Avtomobilski pogon

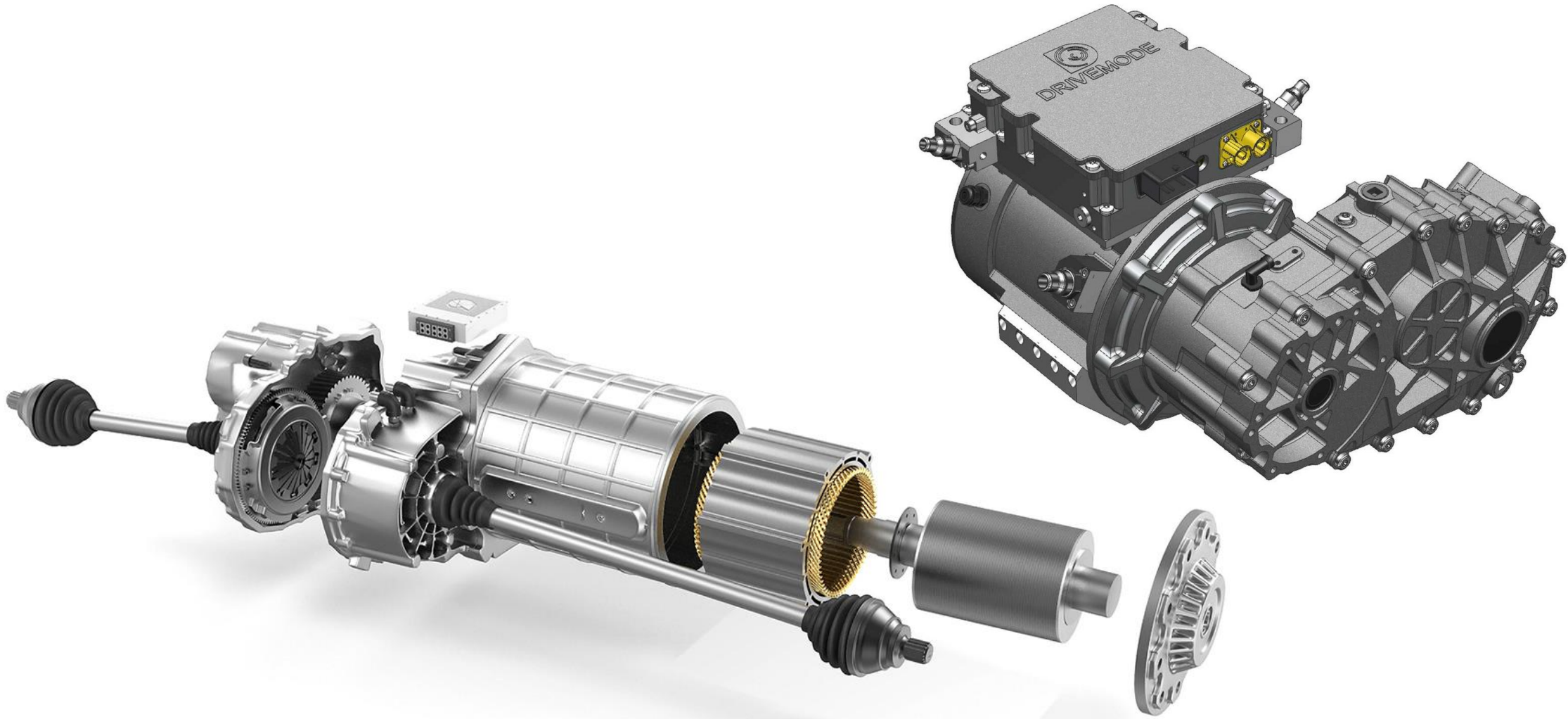

Pogled na motor

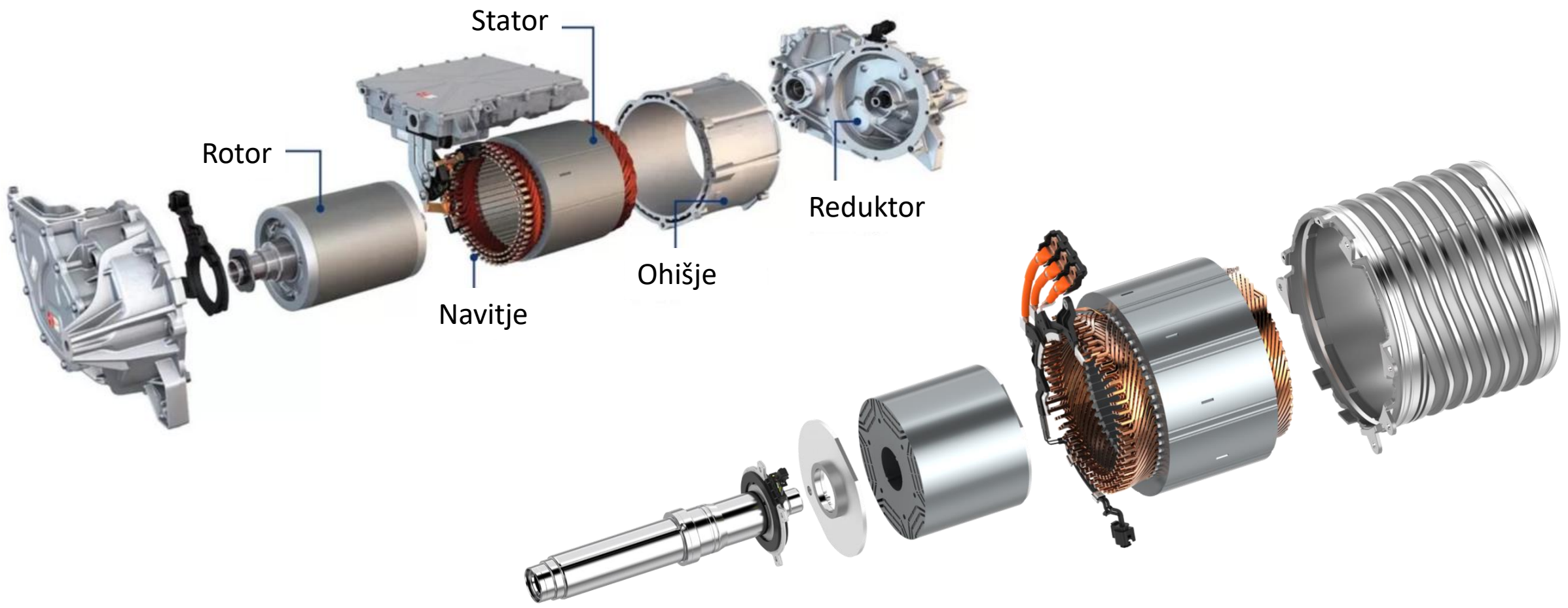

Stator in rotor

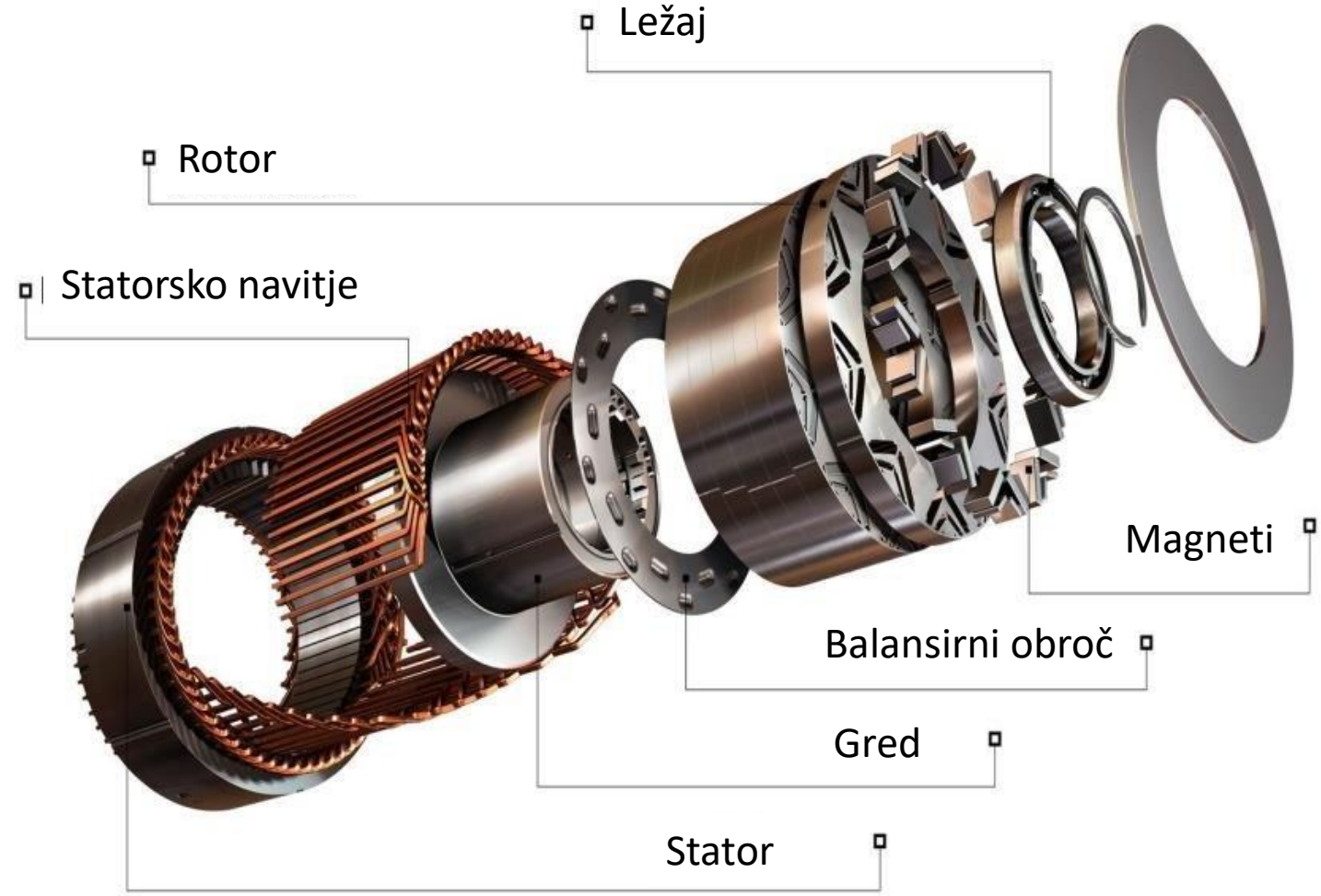



Tirni pogon



Rotor in stator

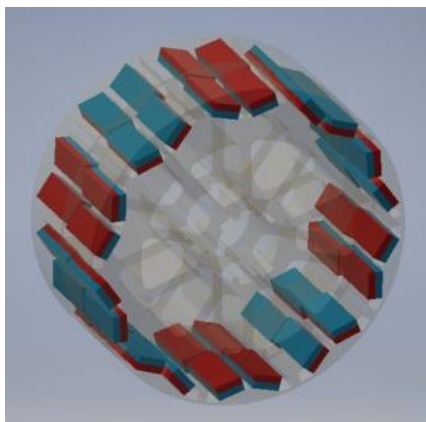
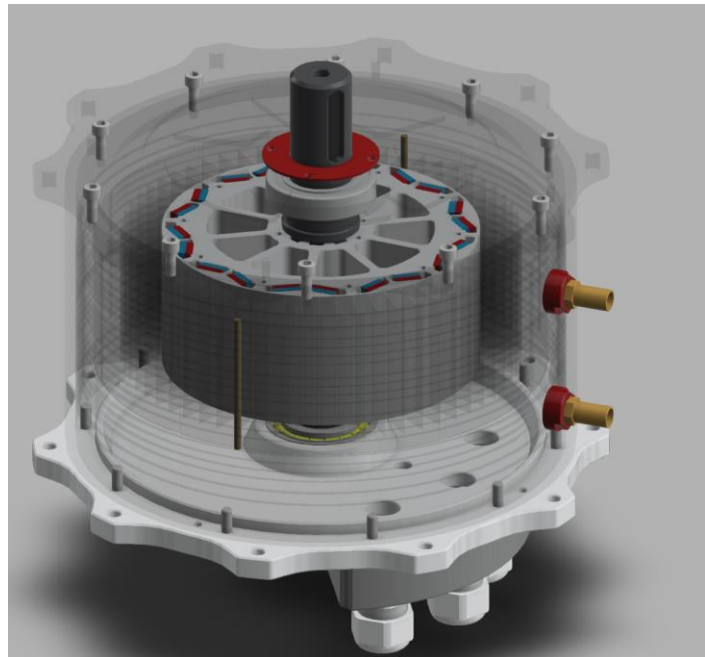

Navitja

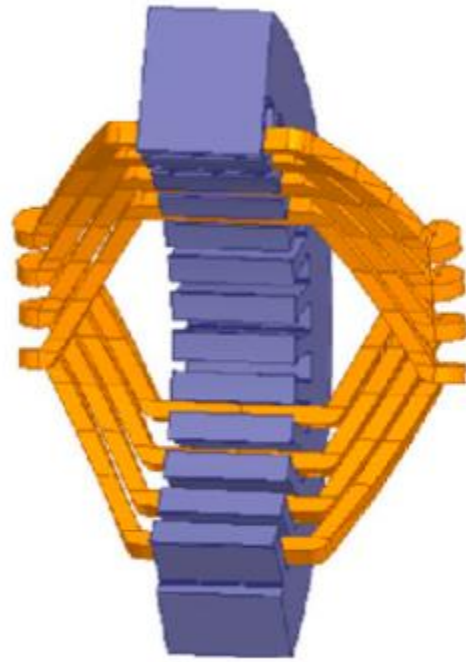

(a)

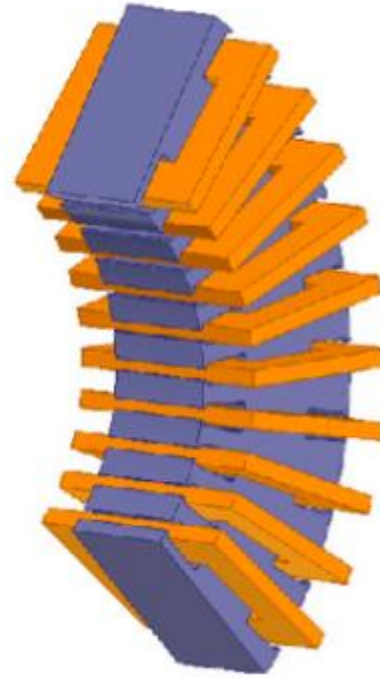

(b)



(c)

Navitja

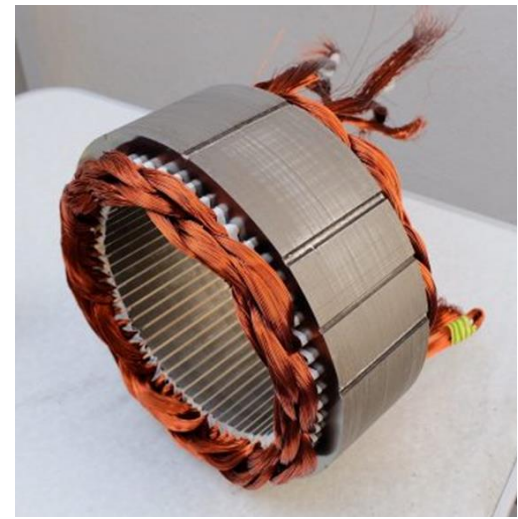
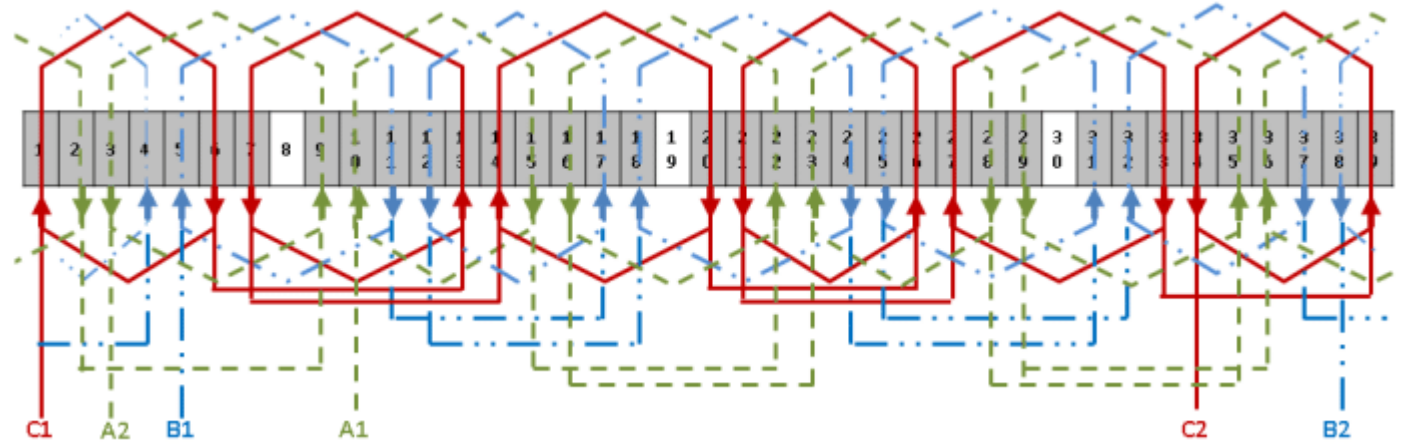
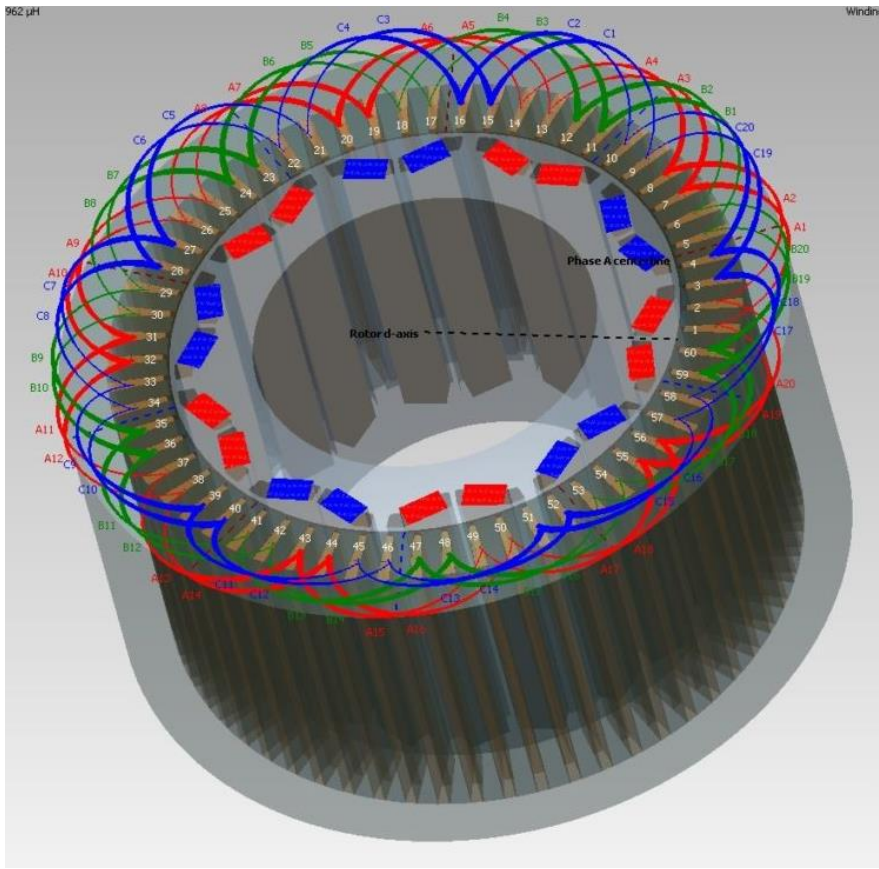

Trifazna inducirana napetost

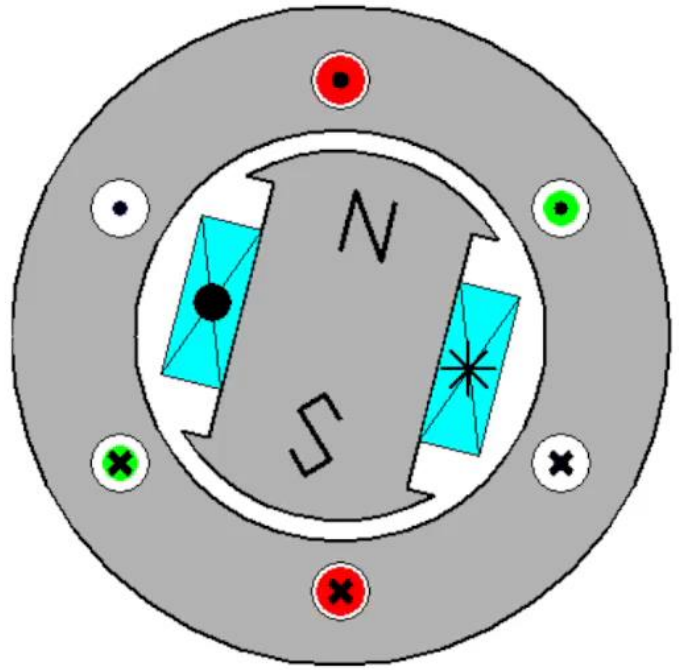

Phase A Phase B Phase C

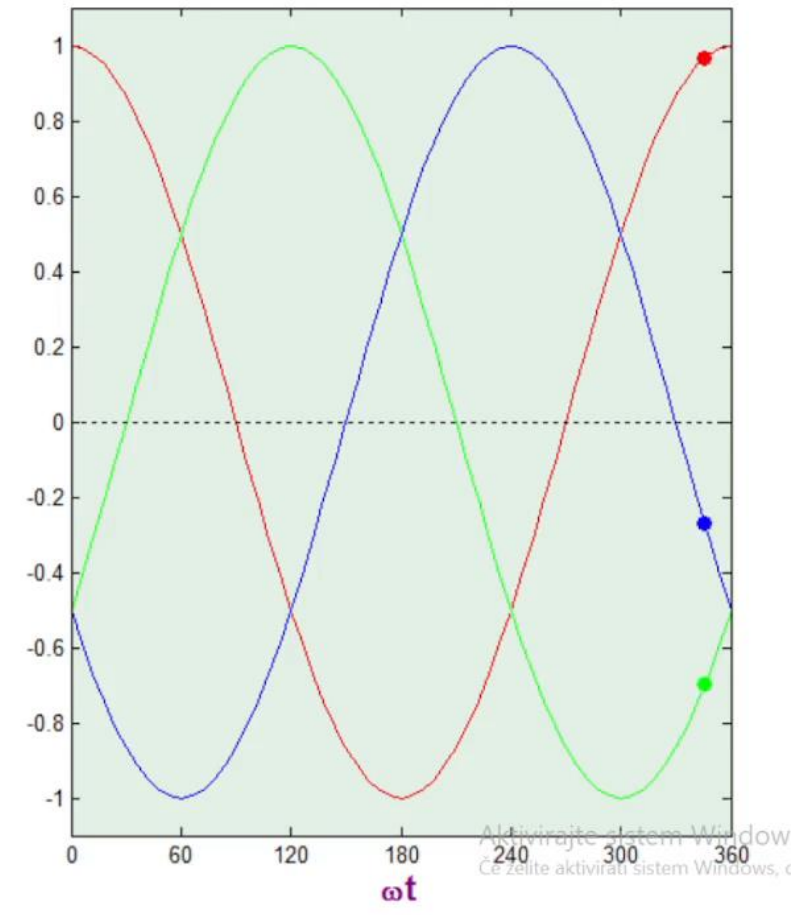

Aktivirajte sistem Windows
Če želite aktivirati sistem Windows, c

Rotor s trajnimi magneti

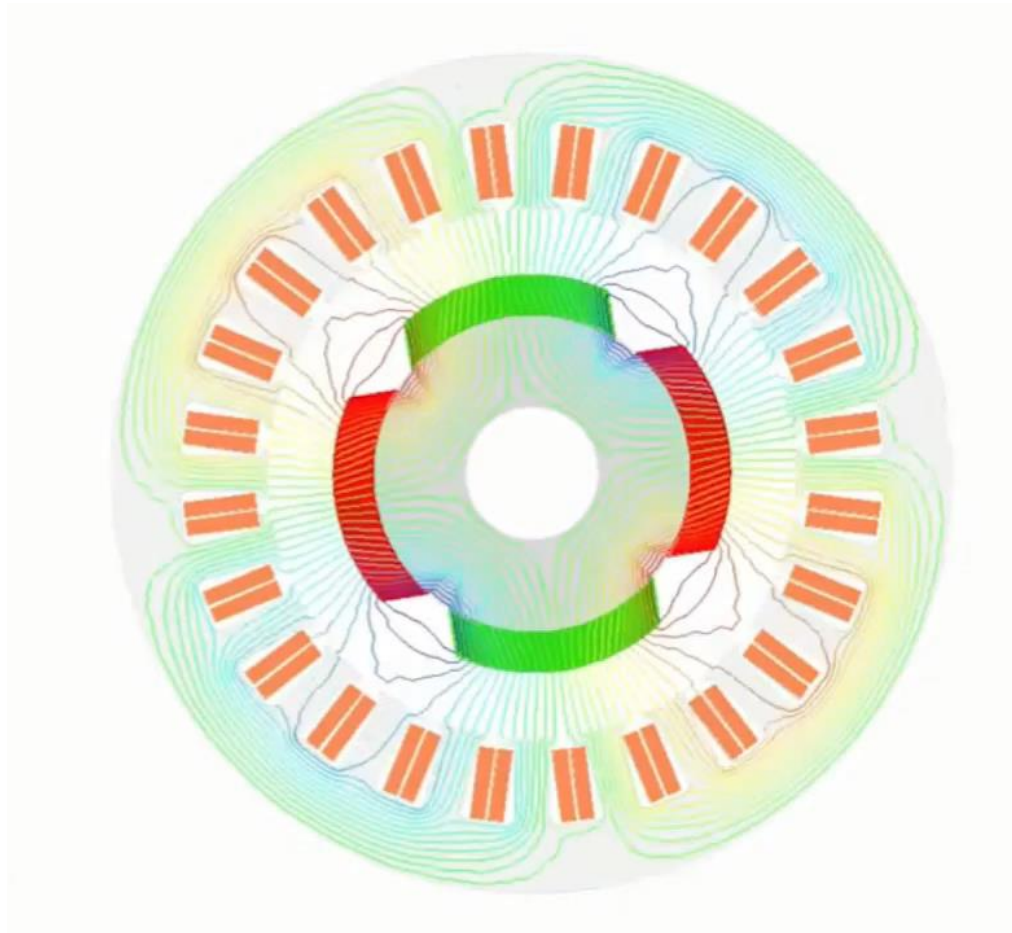

Vrtilno magnetno polje

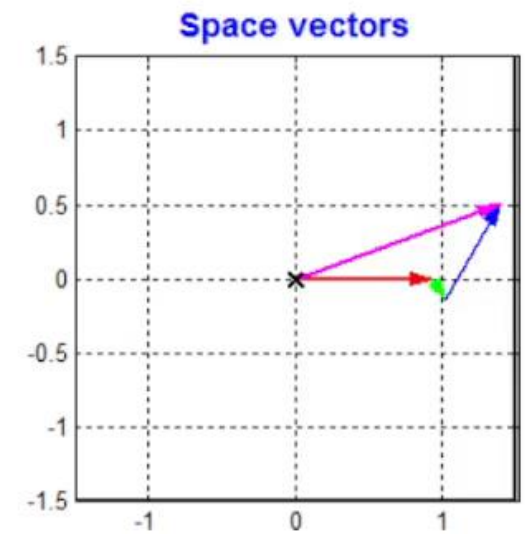
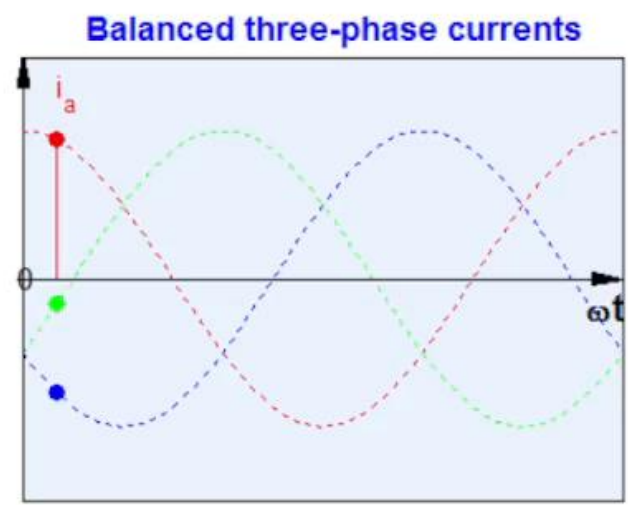
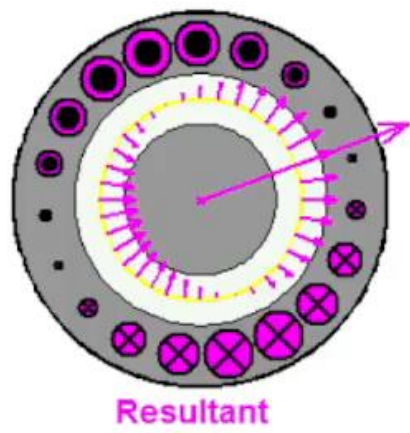
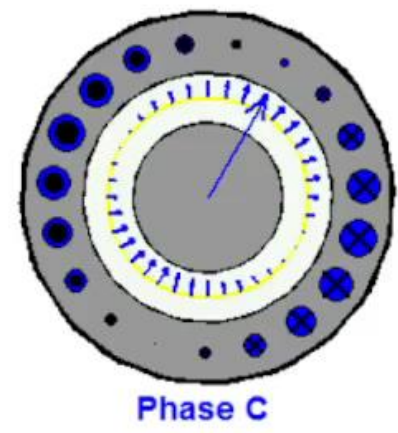
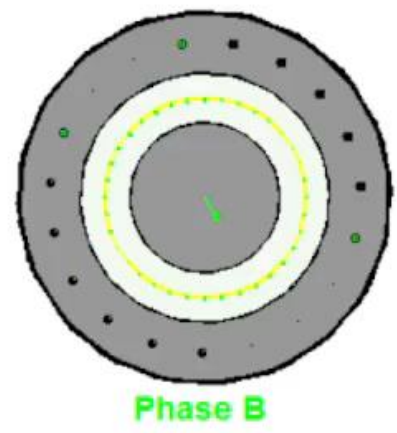
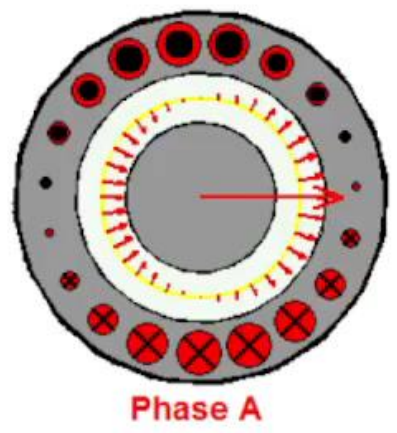

Prostorski kazalci

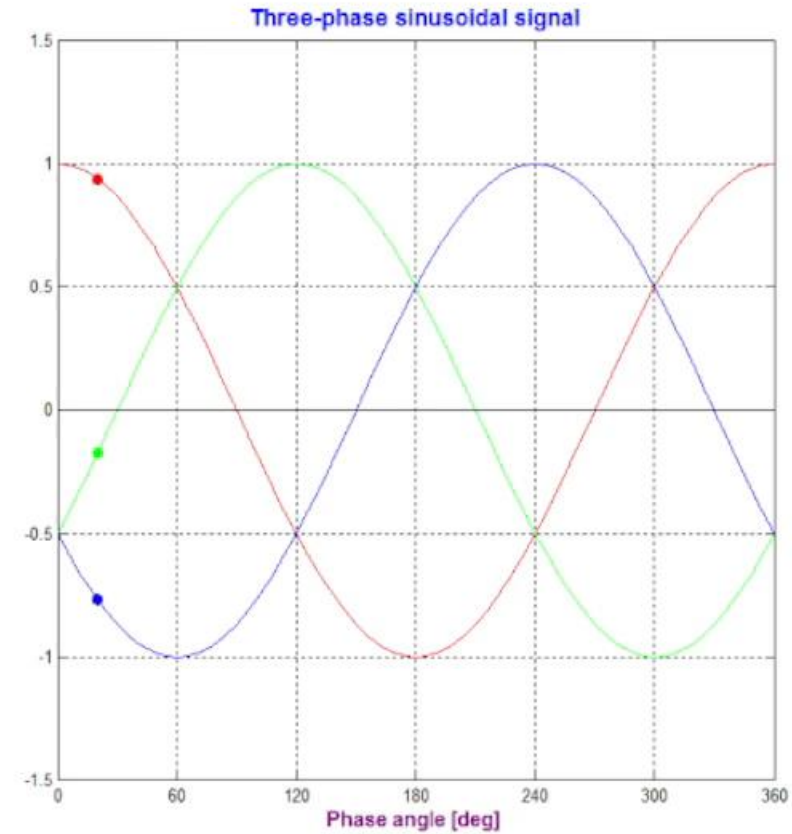
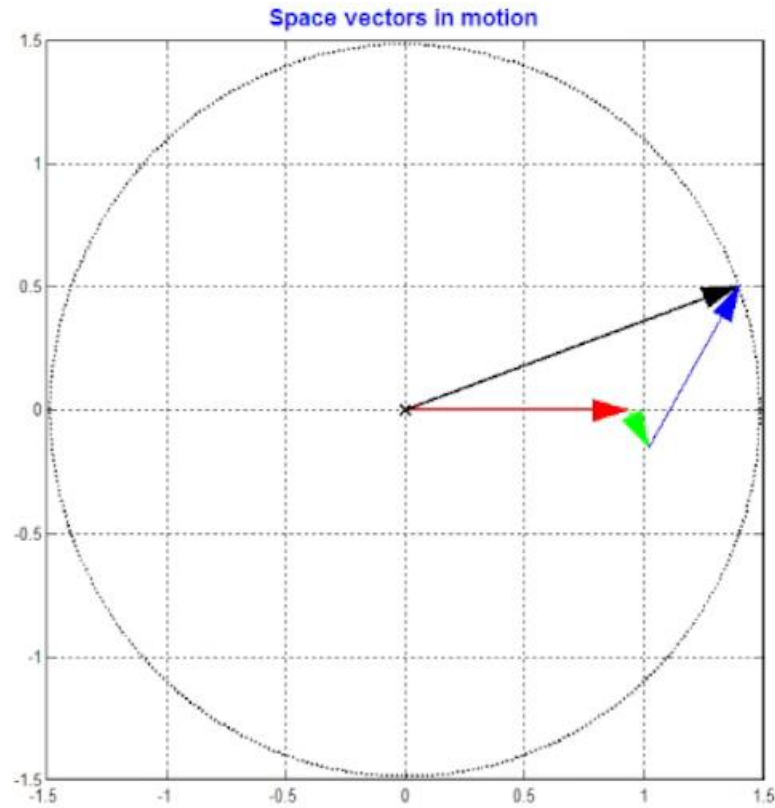

Phase A

Phase B

Phase C

Resultant rotating space vector

Prostorski kazalci in magnetna polja

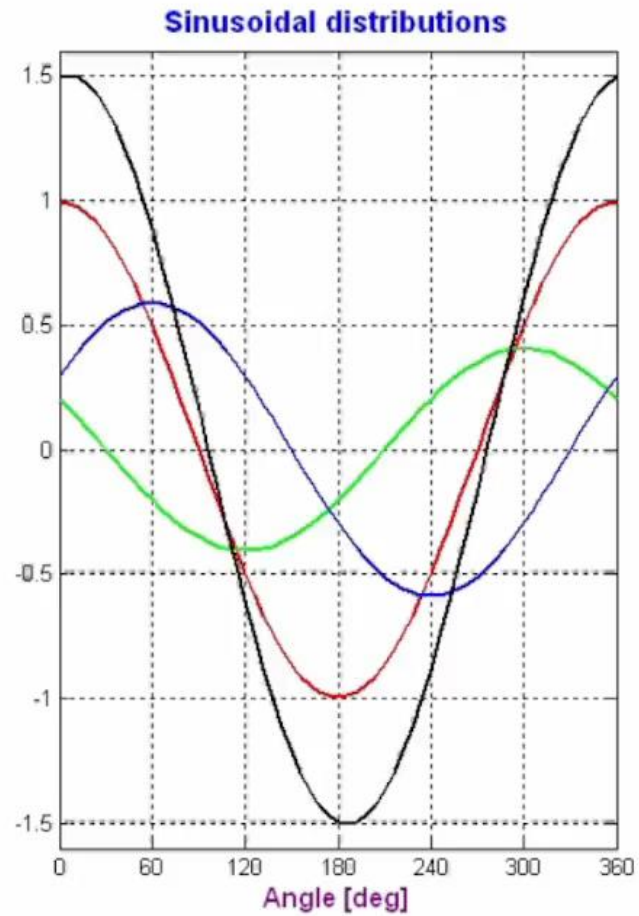
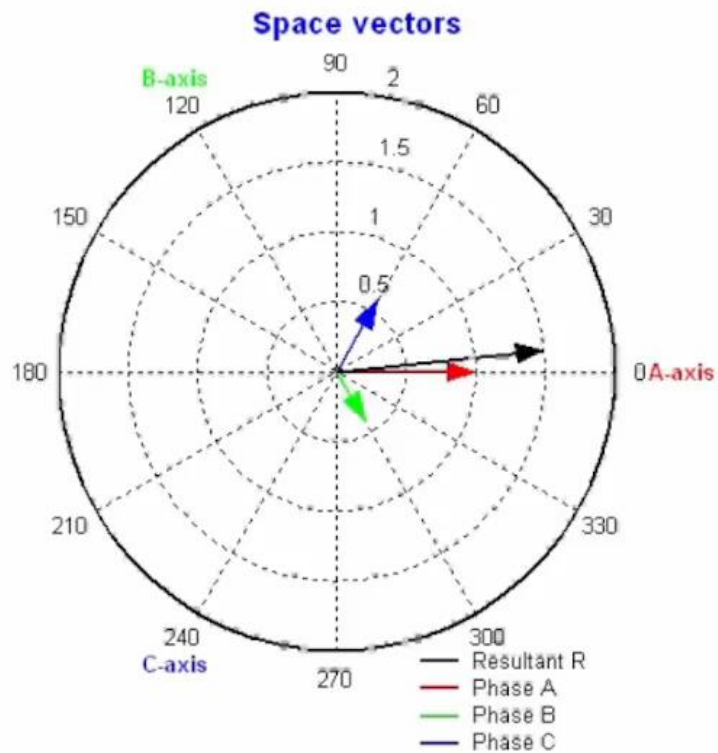

Vrtenje in magnetni pretok

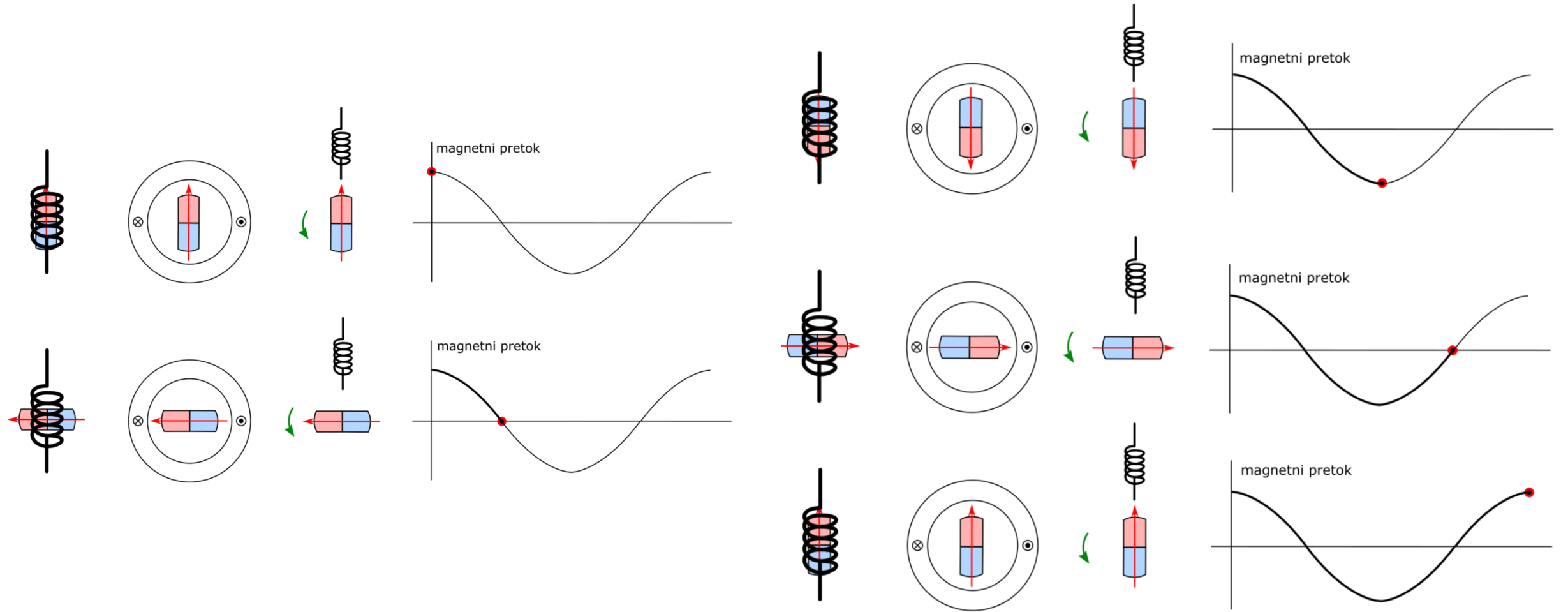

Magnetno poje električnega toka in delovanje sil

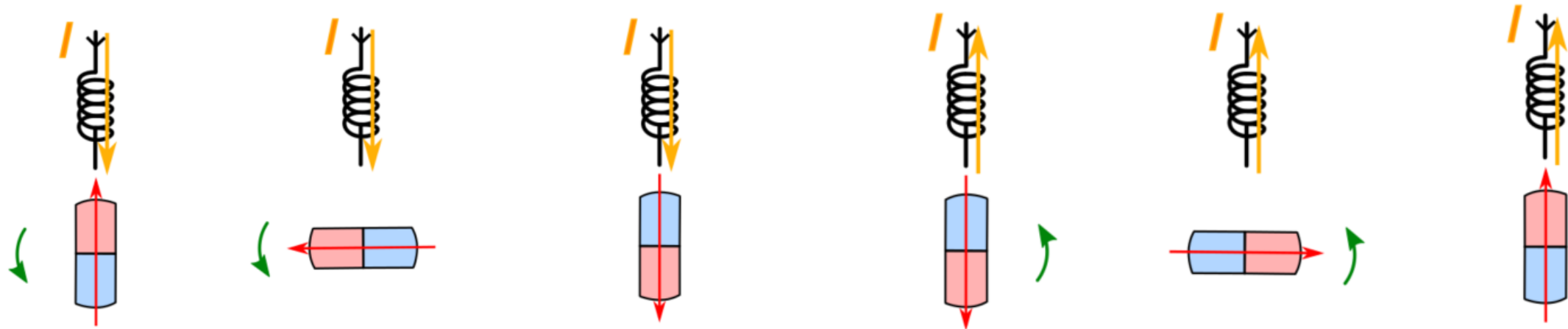

Vrtenje, magnetni pretok in inducirana napetost

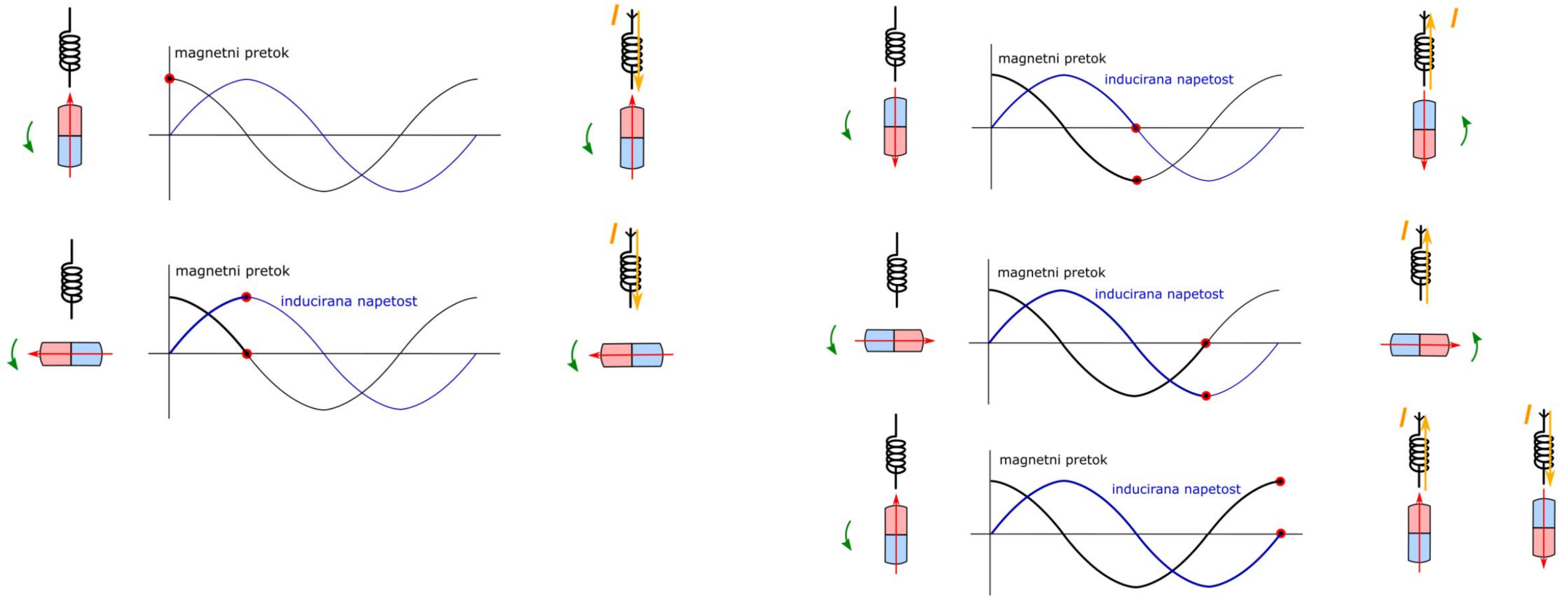

Inducirana napetost, električni tok in magnetna sila

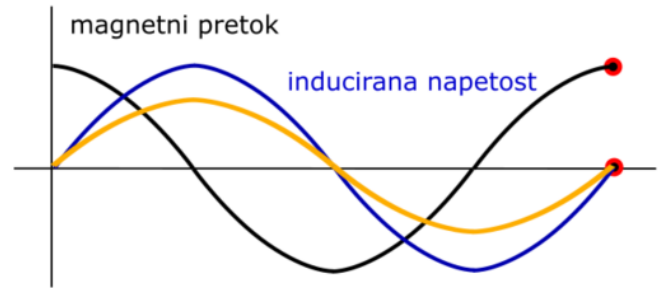
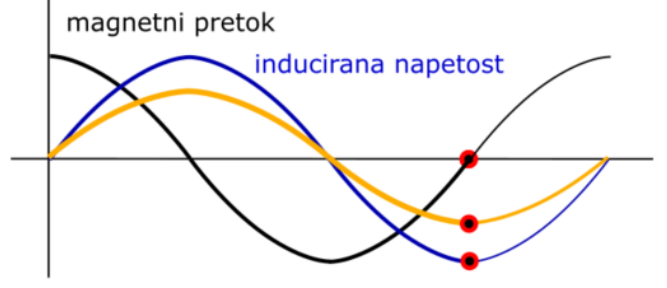
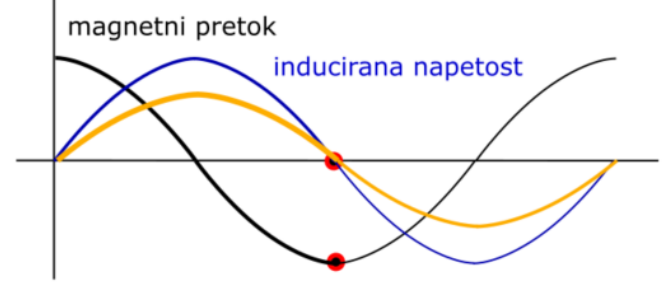
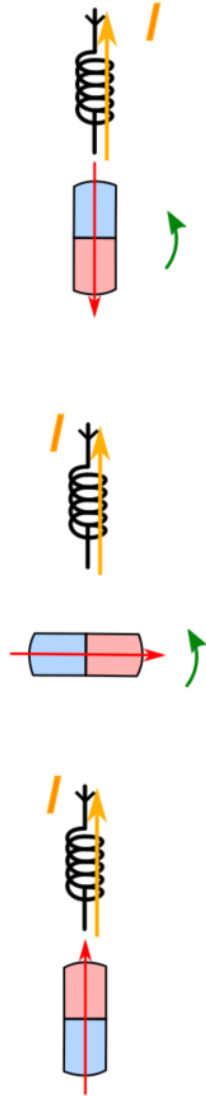
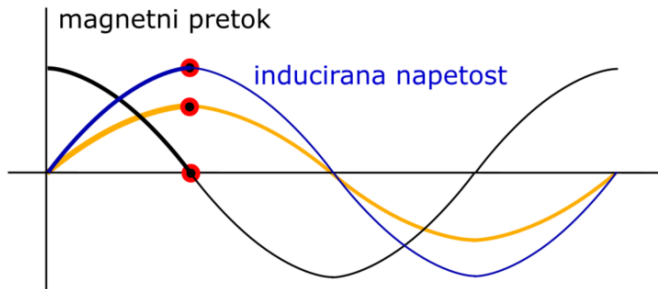
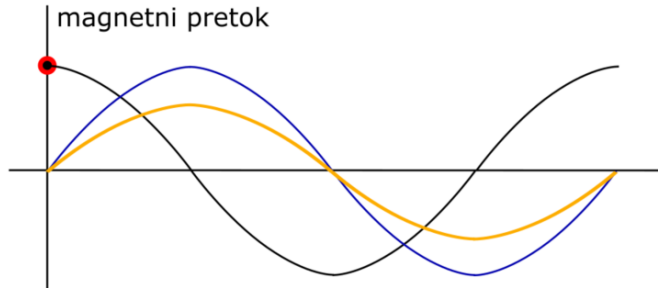
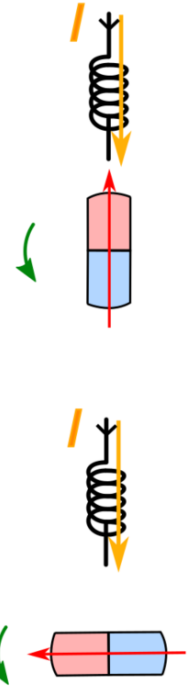

Trifazno statorsko navitje

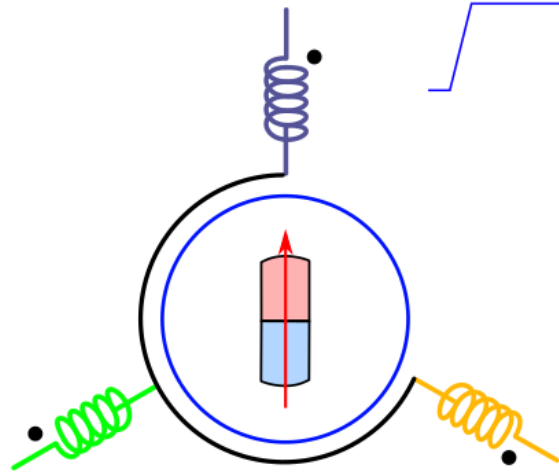

Magnetni pretok in inducirane napetosti

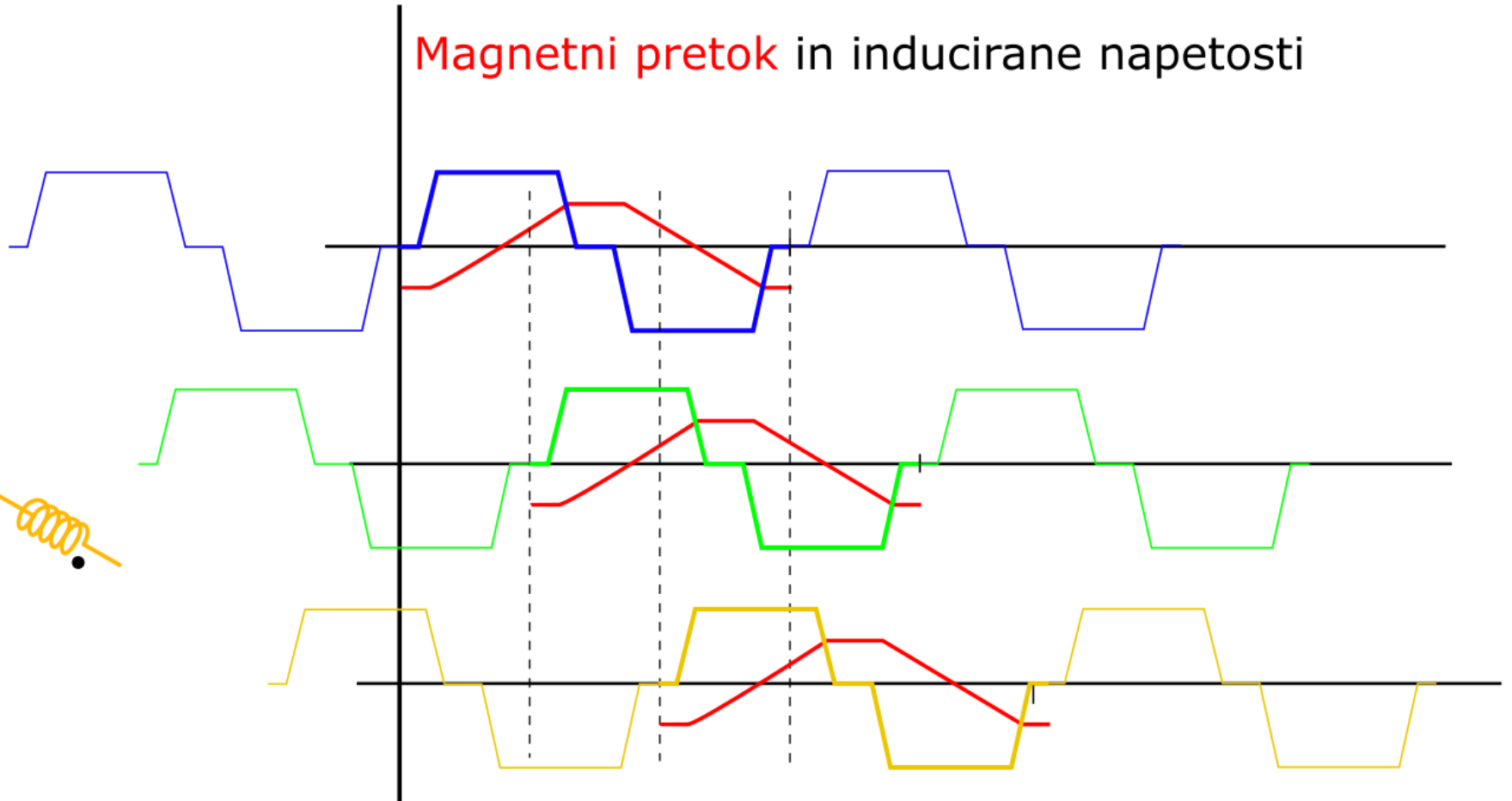

Trifazno statorsko navitje

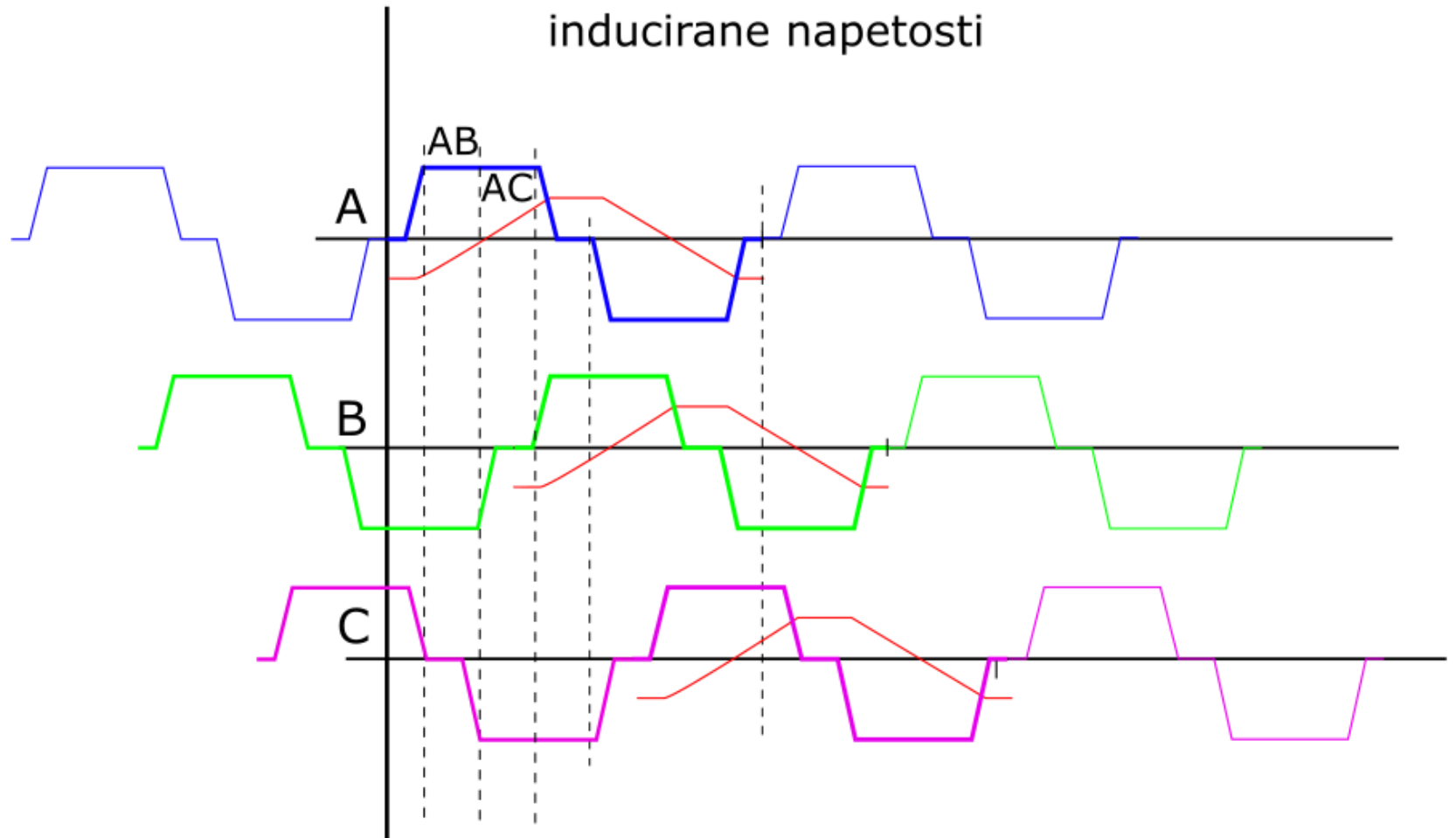
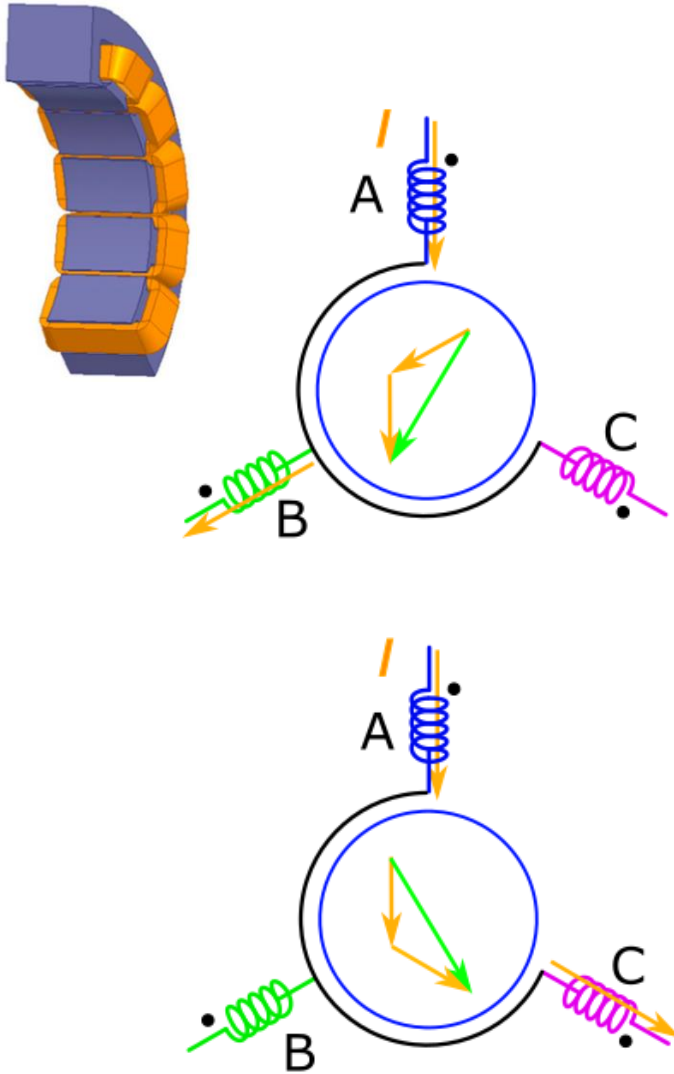

Trifazno statorsko navitje, tok in rezultirajoče magnetno polje v rotorski izvrtini

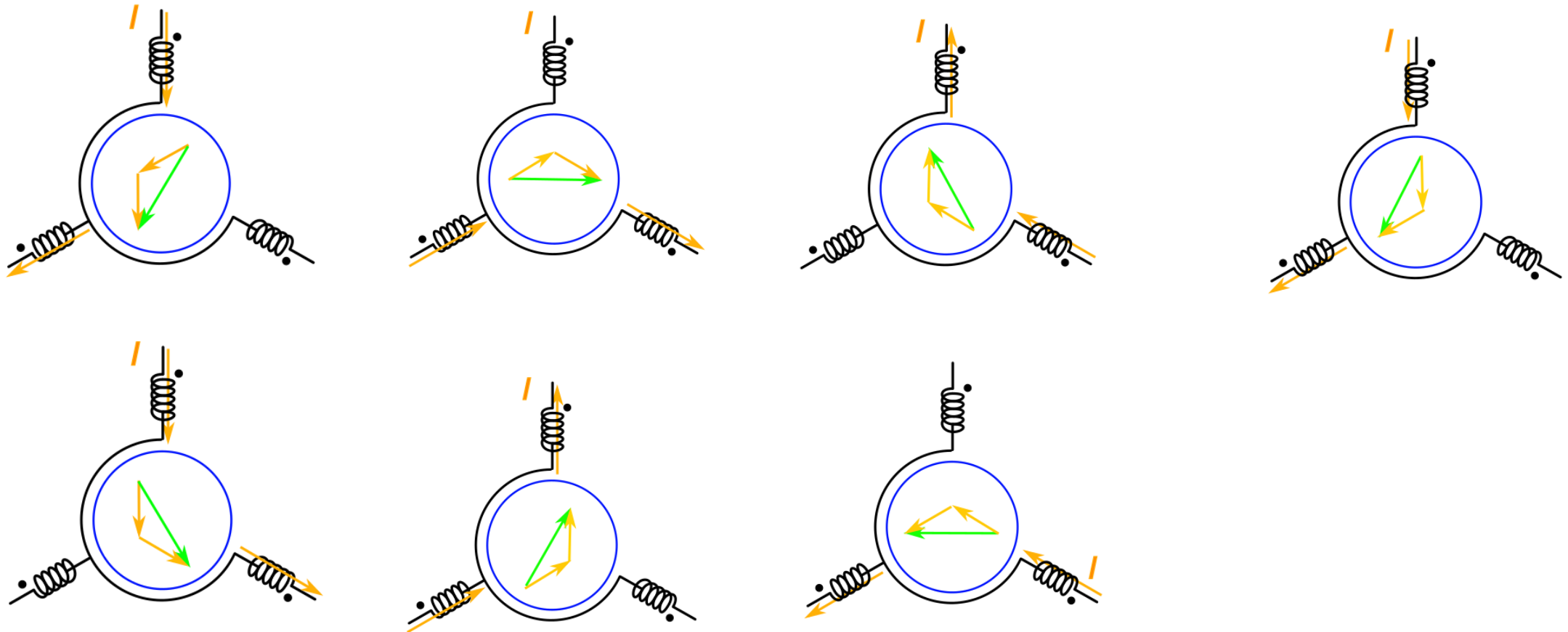

Preklapljanje stikal in vrtilno magnetno polje

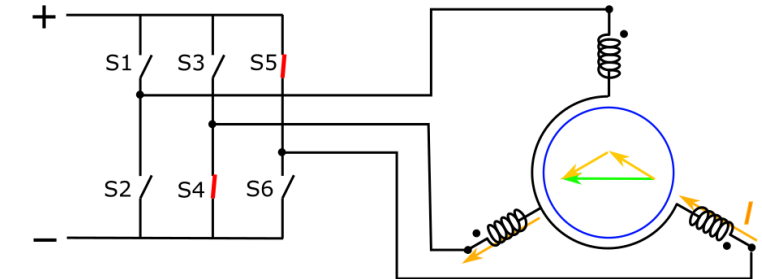
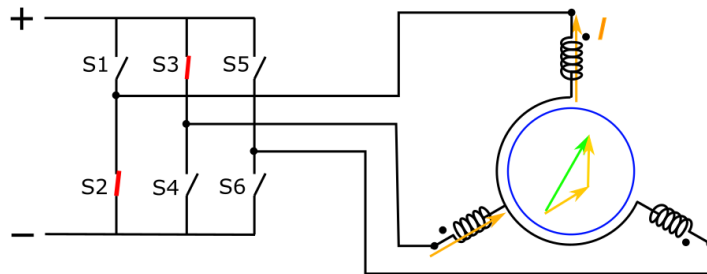
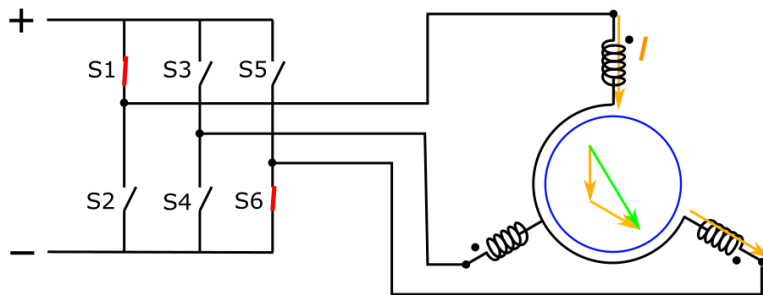
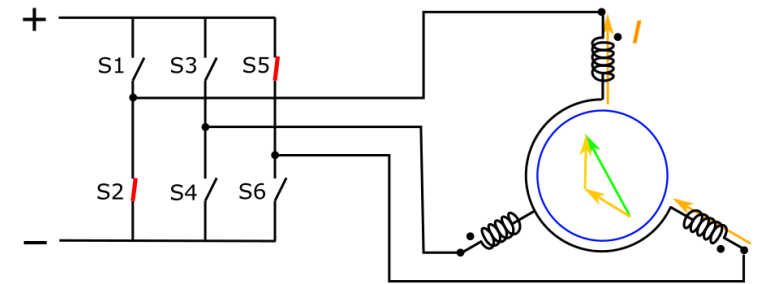
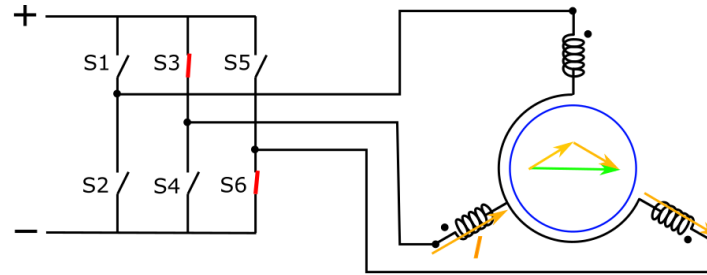
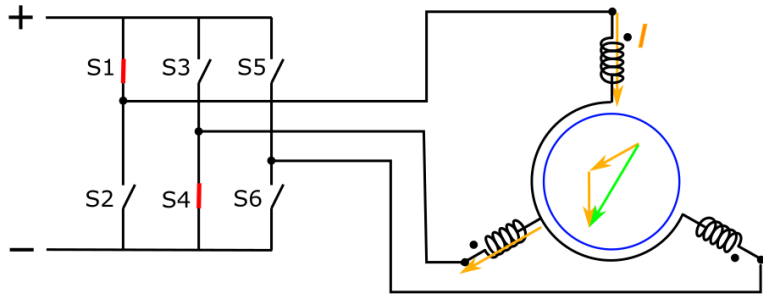

Preklapljanje stikal, vrtilno magnetno polje in delovanje sil na rotor s trajnim magnetom

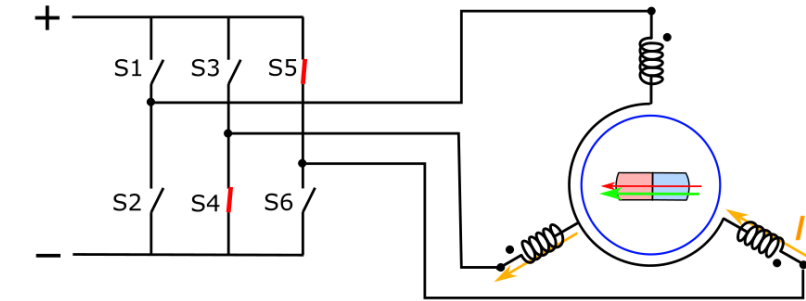
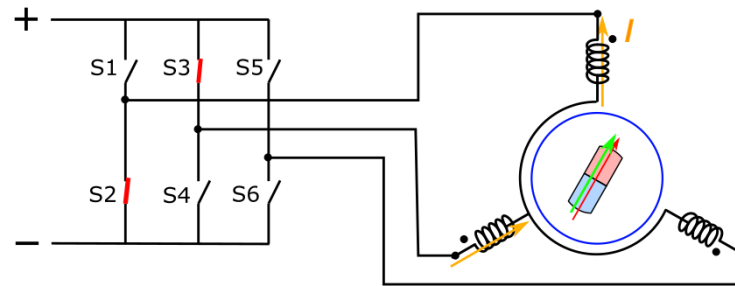
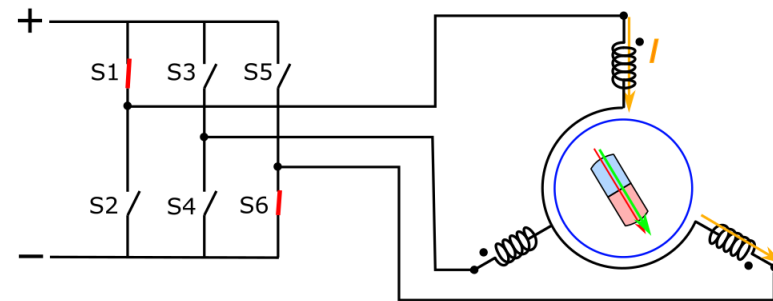
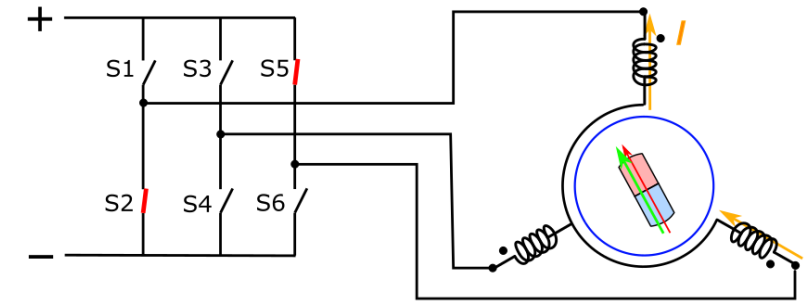
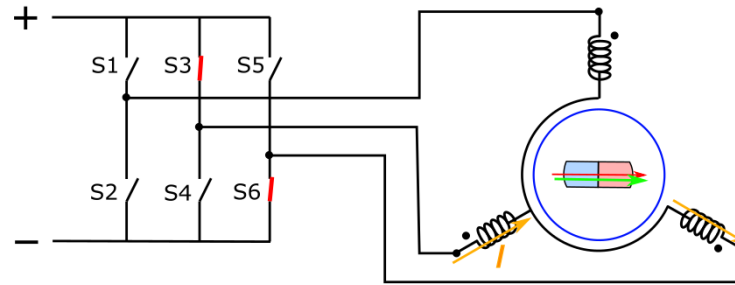
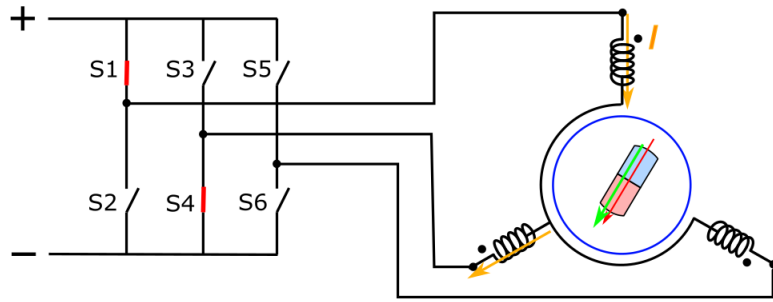

Različne kombinacije stikal in rezultirajoče vrtilno magnetno polje v rotorski izvrtini

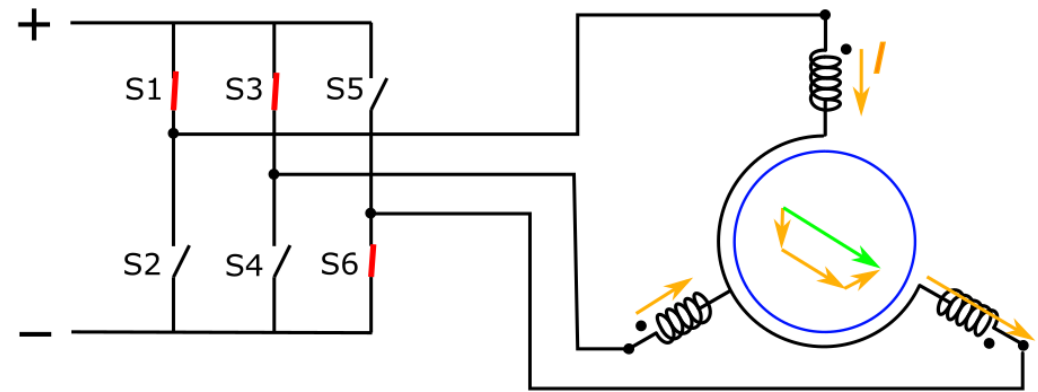
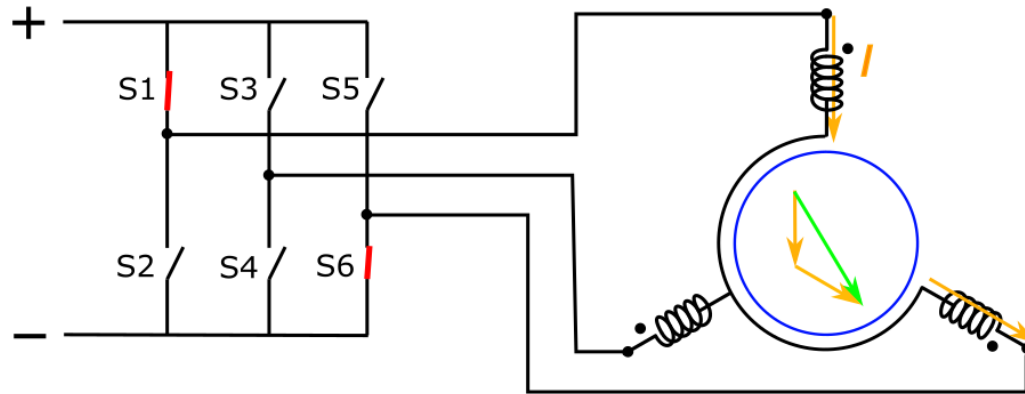
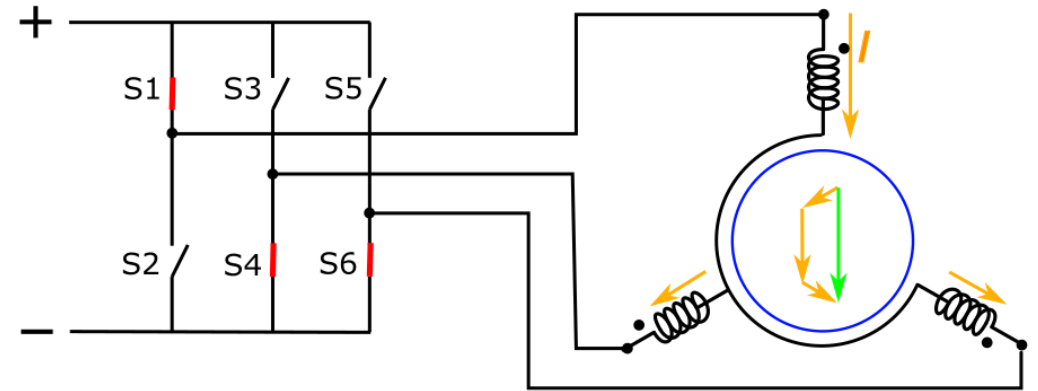
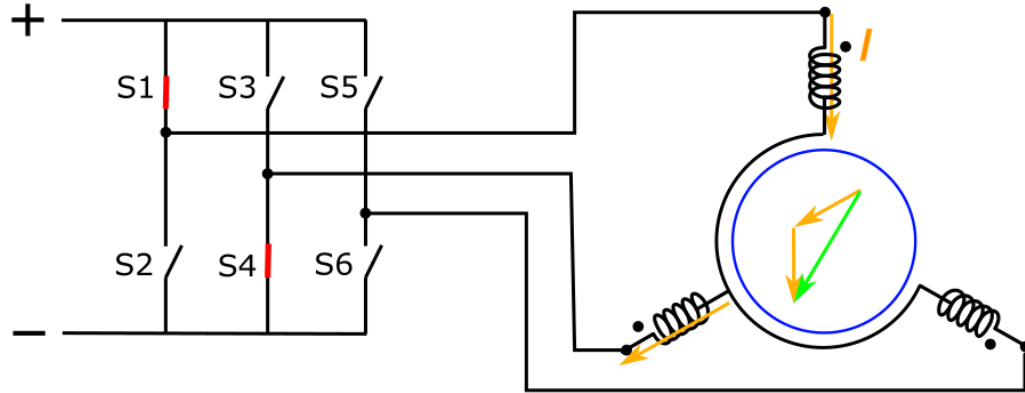

BLDC

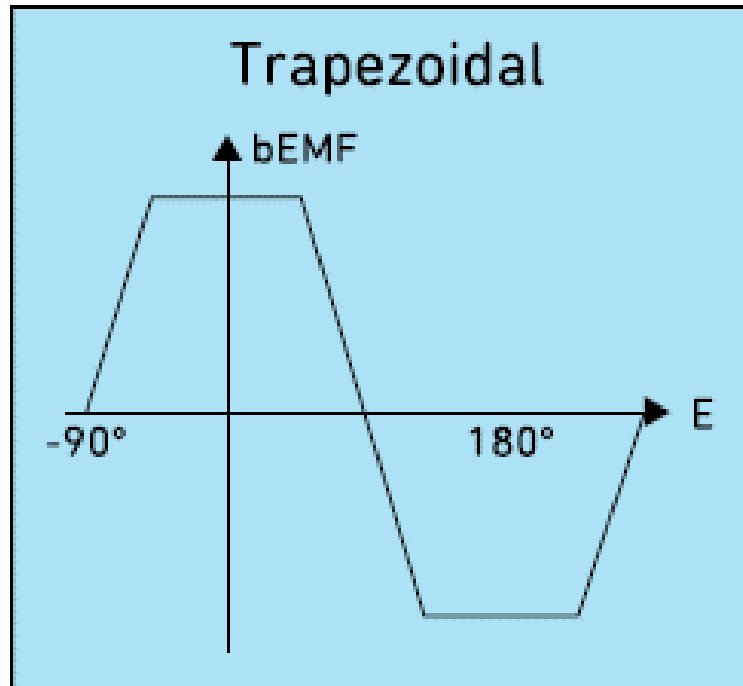

Controlled by Trapezoidal Control

PMSM

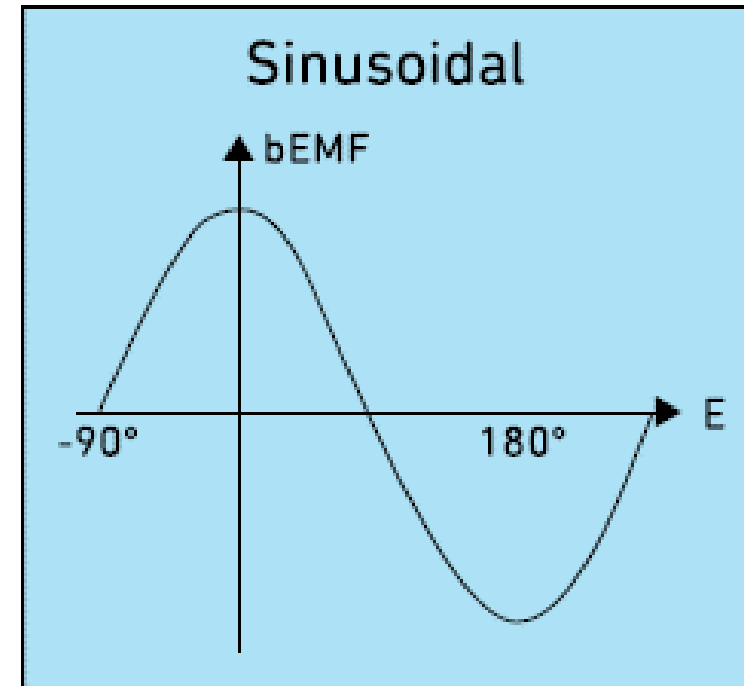

Controlled by Field-Oriented Control

Trifazni toki trapezne oblike

BLDC

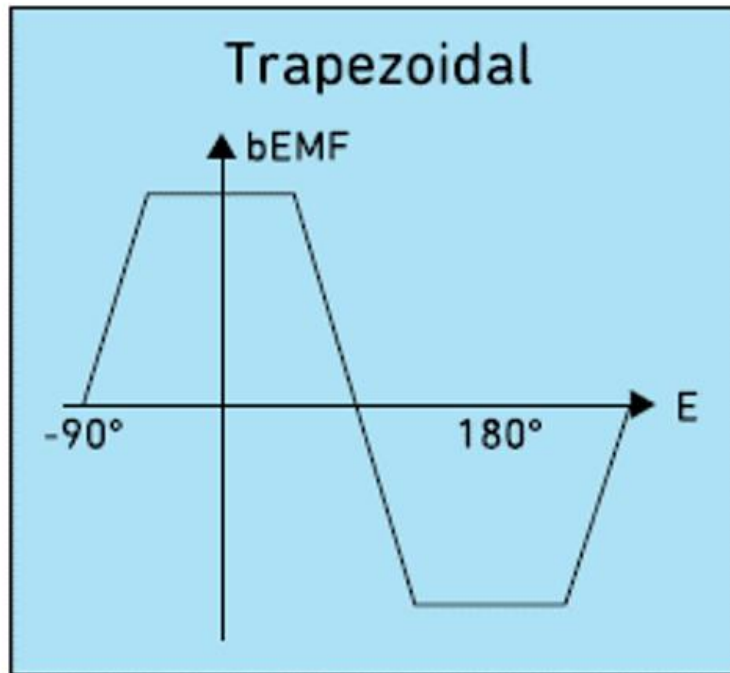

Controlled by Trapezoidal Control

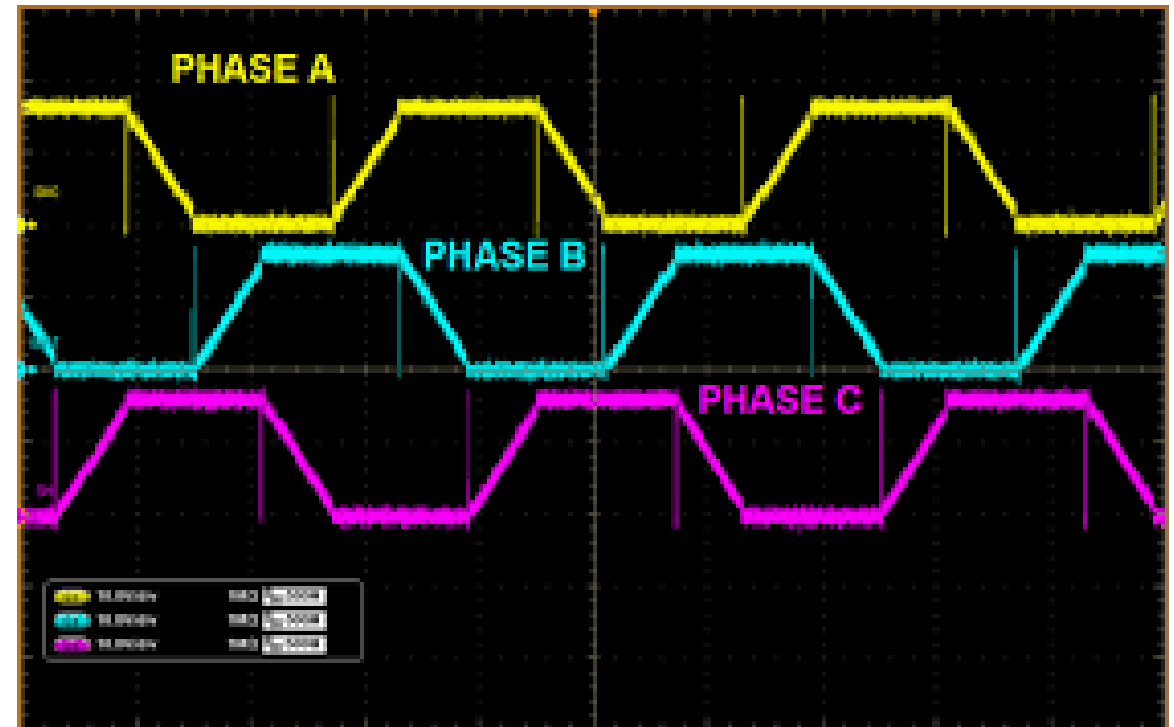

Sinusna oblika toka

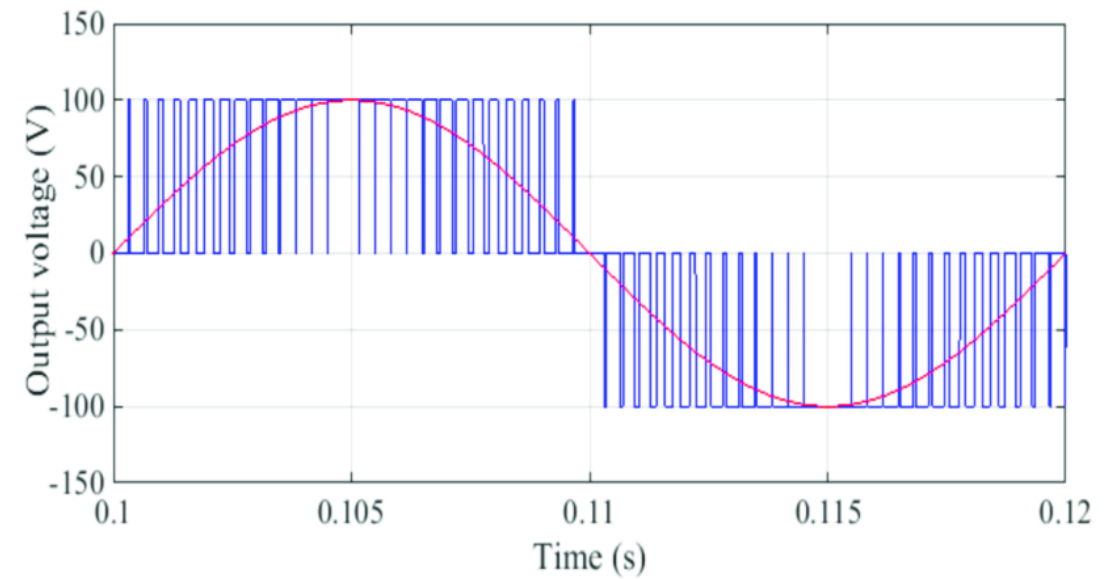
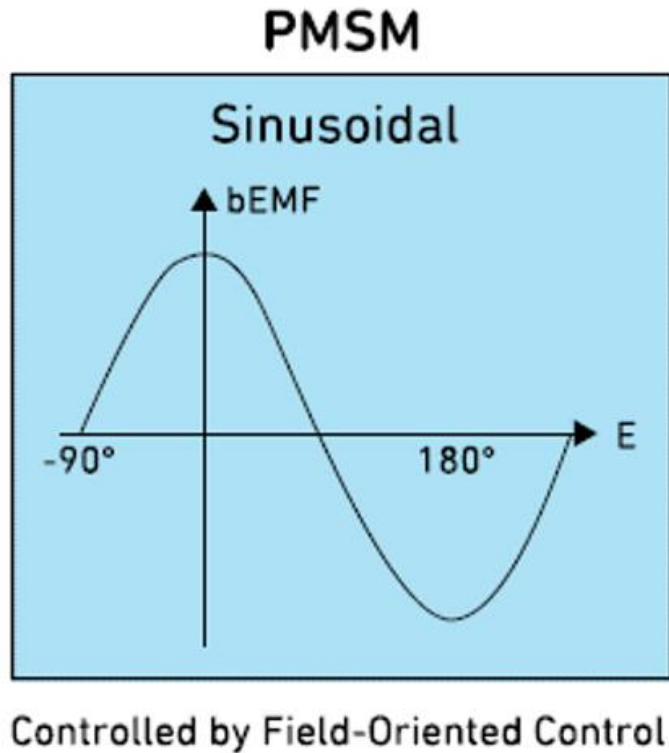

Trifazni sinusni toki

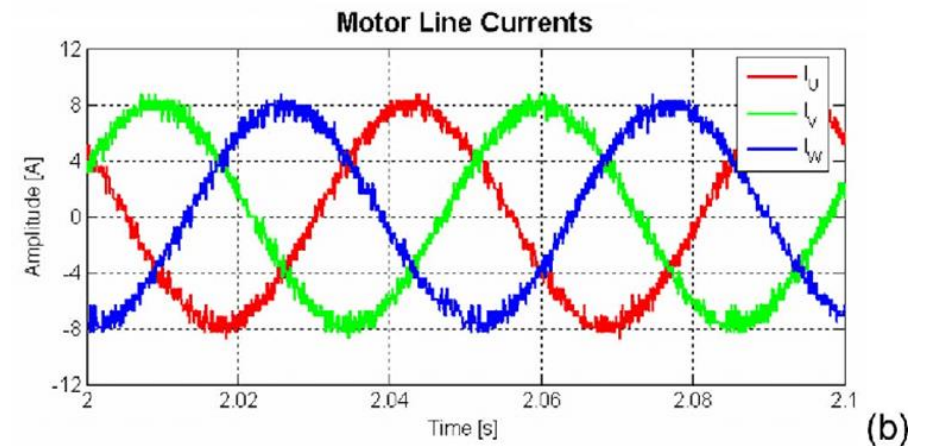
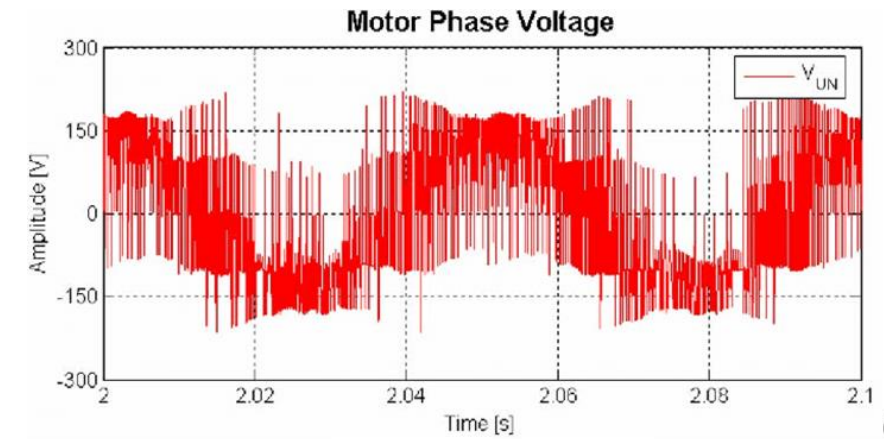
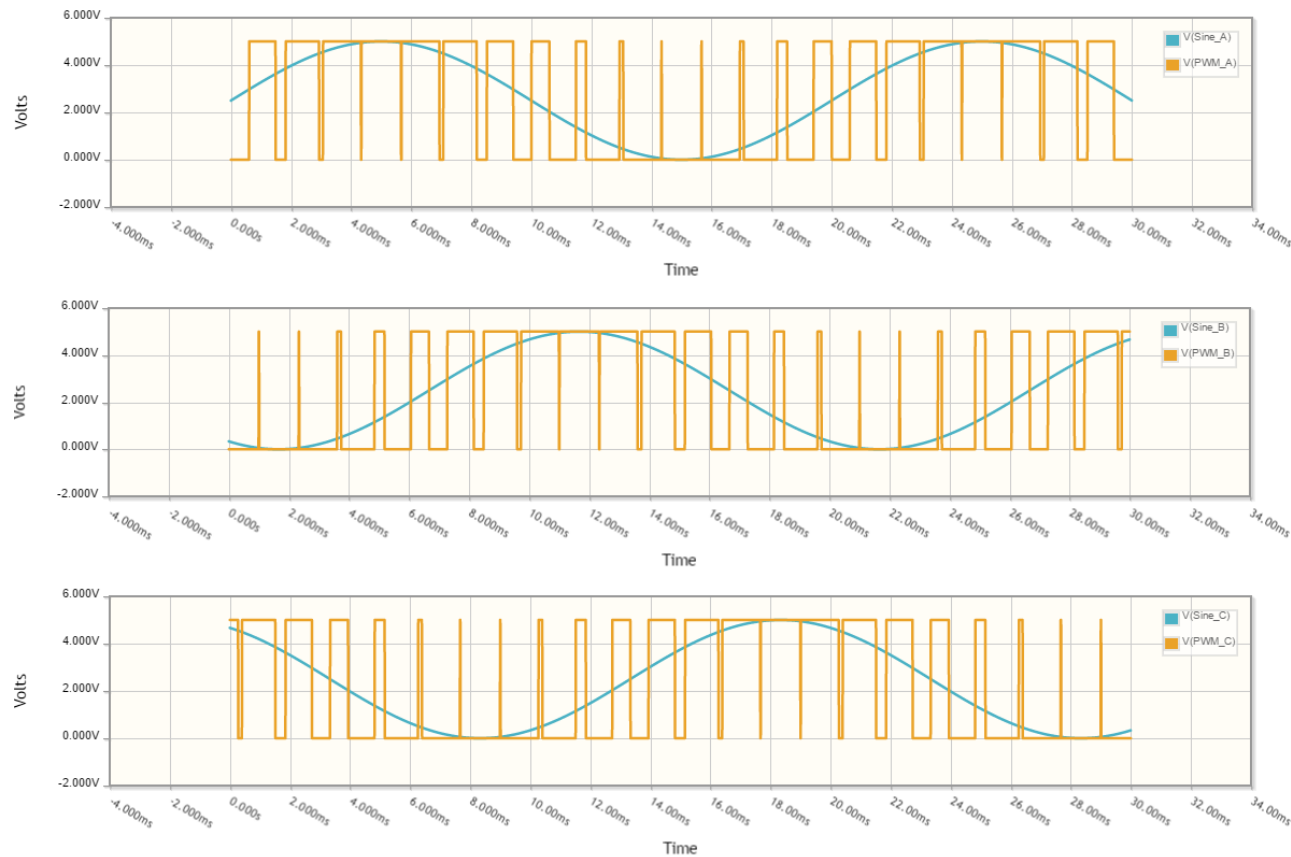

Elektronsko komutirani motorji



BLDC

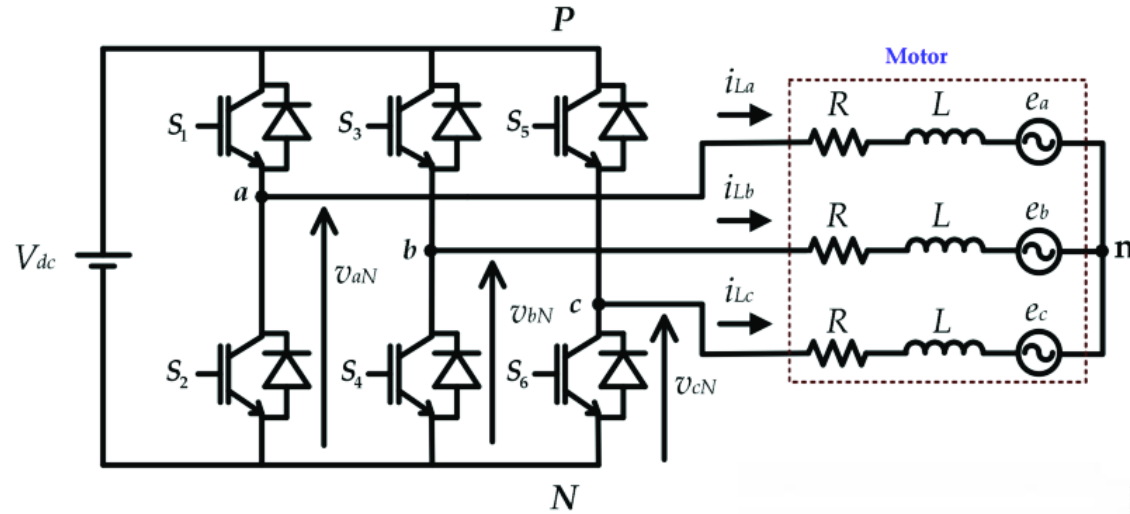

BLAC

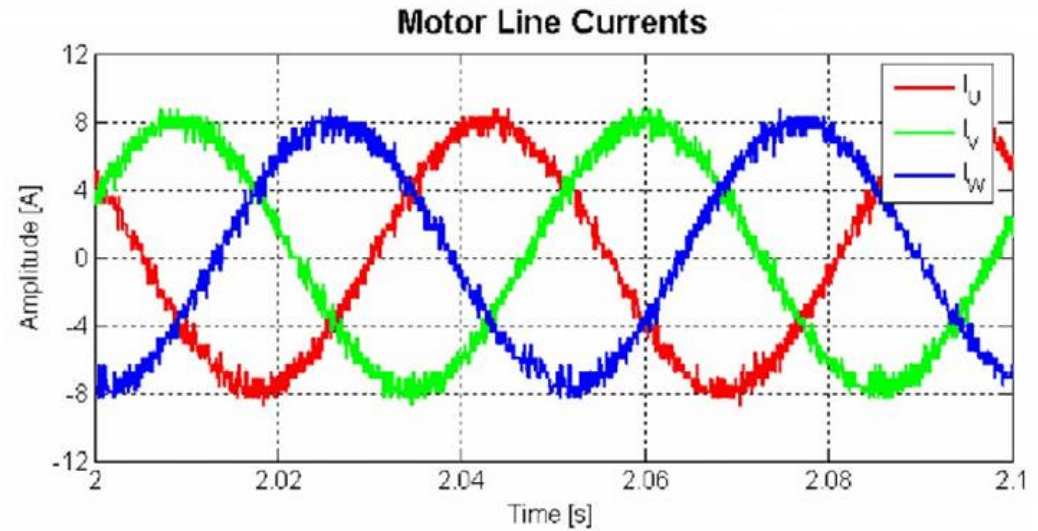
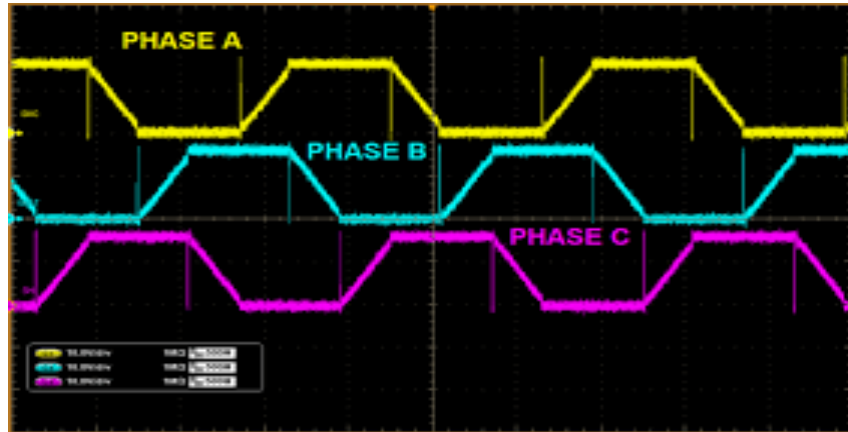

(b)



... in še mnogo ...