

FID1 FID2 FID3 FID4 LPVO Laboratorij za fotovoltaiiko in optoelektroniko

Title <b>Misko_2_MCU</b>		
Size A4	Number	Revision <b>v2.3</b>
Date: 14-Mar-17	Sheet 1 of 2	
File: D:\VAJE\...MISKO_V2_3.SchDoc	Drawn By:	

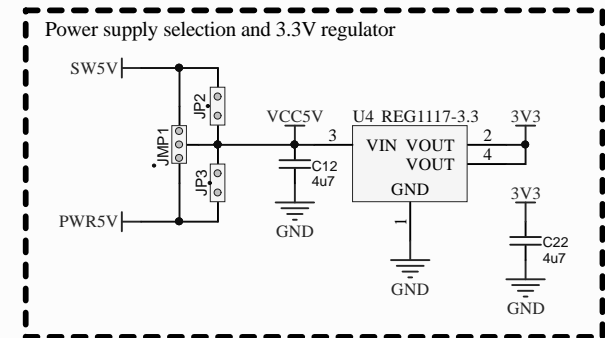
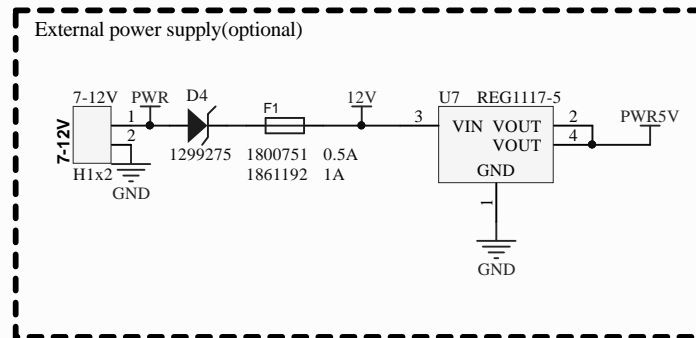
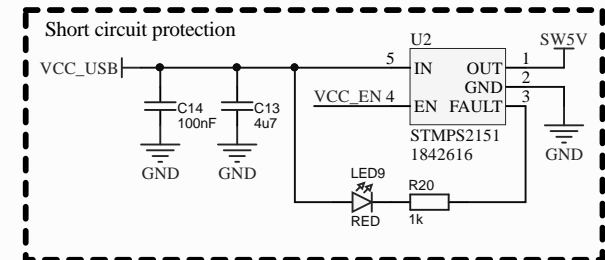
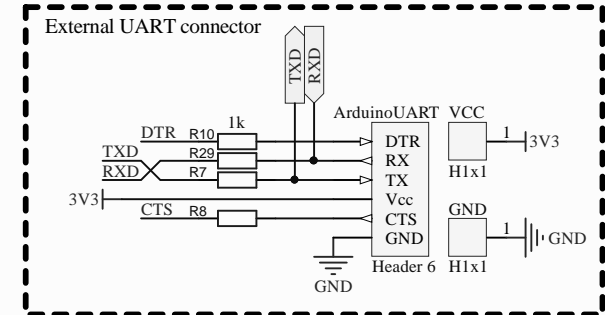
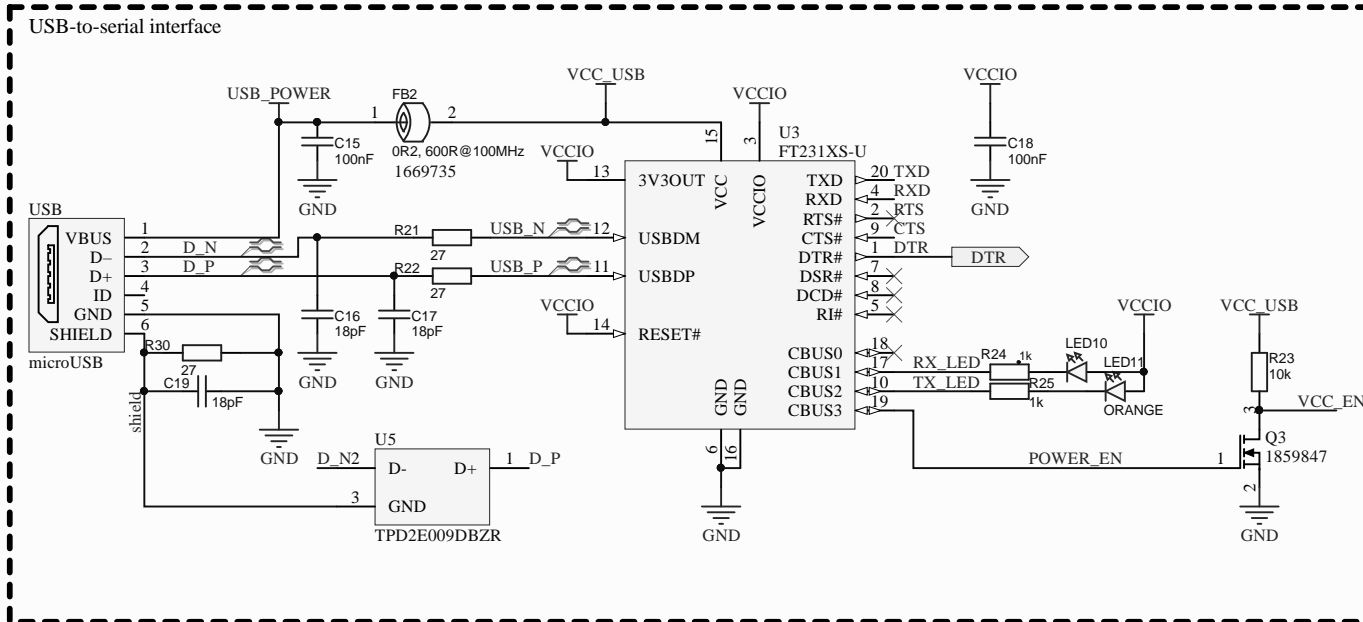

**LPVO** Laboratorij za fotovoltaiiko in optoelektroniko

Title <b>MISKO_2_USB</b>		
Size A4	Number	Revision <b>v2.3</b>
Date:	14-Mar-17	Sheet 2 of 2
File:	D:\VAJE\...USB.SchDoc	Drawn By: